

Display Elektronik GmbH

DATA SHEET

MIP Display

DE MIP400240A-W-PW

(2,7“ MIP, Mono + Backlight)

Product Specification

Ver.: 1

18.05.2026

Contents

1. General Description and Features	4
1.1 Features	4
1.2 LCD Module	4
2. Mechanical Information	4
3. Electrical Specifications	5
3.1 Absolute Max. Ratings	5
3.2 Timing Characteristic of The LCD	7
3.3 Power Consumption	9
4. Optical Characteristics	10
4.1 Optical characteristic of the LCD.....	10
5. I/O Terminal	12
5.1 Pin Assignment (LCD)	12
5.2 Pin Assignment (Backlight)	12
5.3 Block Diagram	13
6. Displayed Color and Input Data	14
7. Reliability Condition	15
8. Dimensional Outlines	16

1. General Description and Features

This TFT-LCD module is a reflective active-matrix with slightly transmissive memory liquid crystal display module with CG silicone thin film transistor.

1.1 Features

- Reflective active-matrix with slightly transmissive panel of white and black.
- 2.7" WQVGA screen has 400*240 resolution. (96,000 pixels stripe array)
- Display control by serial data signal communication.
- Super low power consumption TFT panel.

1.2 LCD Module

Item	Specification	Unit
Screen Size	2.7 Inch	Diagonal
Display Resolution	400 x 240	Pixel
Active Area	58.80 x 35.28	mm
Outline Dimension	63.20 x 43.22 x 2.445	mm
Display Mode	Memory In Pixel, Monochrome / Normally White	--
Surface Treatment	AG	
Surface Hardness	>=3H	--
Pixel Array	Stripe Array	--
Pixel Size	0.147 x 0.147	mm
Input Interface	3 Wire SPI	--

2. Mechanical Information

Item		Min.	Typ.	Max.	Unit	Note
Module Size	Horizontal (H)	62.90	63.20	63.50	mm	--
	Vertical (V)	42.92	43.22	43.52	mm	--
	Thickness (T)	2.145	2.445	2.745	mm	(1)
Weight		--	(TBD)	--	g	--

Note (1) Not Include Component. Refer to the Outline Dimension Drawing as attached.

3. Electrical Specifications

3.1 Absolute Max. Ratings

3.1.1 Absolute Ratings of Environment

If the operating condition exceeds the following absolute maximum ratings, the TFT LCD module may be damaged permanently.

($T_a=25\pm 2^\circ\text{C}$, $V_{SS}=\text{GND}=0$)

Item	Symbol	Min.	Max.	Unit	Note
Storage Temperature	T_{STG}	-30	80	$^\circ\text{C}$	(1)
Operating Temperature	T_{OPR}	-20	70	$^\circ\text{C}$	(1,2,3)

Note (1) 95 % RH Max. ($40^\circ\text{C} \geq T_a$). Maximum wet-bulb temperature at 39°C or less. ($T_a > 40^\circ\text{C}$)
No condensation.

Note (2) In case of below 0°C , the response time of liquid crystal (LC) becomes slower and the color of panel becomes darker than normal one. Level of retardation depends on temperature, because of LC's character

Note (3) Only operation is guaranteed at operating temperature. Contrast, response time, another display quality are evaluated at $+25^\circ\text{C}$.

3.1.2 Electrical Absolute Maximum Ratings

3.1.2.1 TFT-LCD Module

($V_{SS}=\text{GND}=0$)

Parameter	Symbol	Min.	Max.	Unit	Remark
Power Voltage	VDD	-0.3	5.8	V	--
	VDDA	-0.3	5.8	V	--
	VHI	--	VDD	V	--
	VLI	-0.3	--	V	--

3.1.3 DC Electrical Characteristics of the TFT LCD

(Ta=25±2°C, Vss=GND=0)

Item	Symbol	Min.	Typ.	Max.	Unit	Remark	
Power Supply	VDD	4.8	5.0	5.5	V	--	
	VDDA	4.8	5.0	5.5	V	--	
Input Voltage for Logic	Hi	VIH	2.7	3.0	VDD	V	--
	Lo	VIL	VSS	VSS	VSS+0.15	V	--

Note (1) fv =60Hz , Ta=25°C , Display pattern : Black pattern



3.1.4 Backlight Specification

Item	Symbol	Min.	Typ.	Max.	Unit	Remark
Backlight Specification	IB	--	80	--	mA	
Voltage of Backlight Unit	VB	--	3	--	V	(1)
Power Consumption	P _{BL}	--	240	--	mW	(2)

Note (1) LEDs in 1 series x 4 parallel type.

(2) Where IB = 80 mA, VB = 3.0 v , P_{BL} = VB × IB

(3) The environmental conducted under ambient air flow, at Ta=25°C±2°C, 60%RH±5%

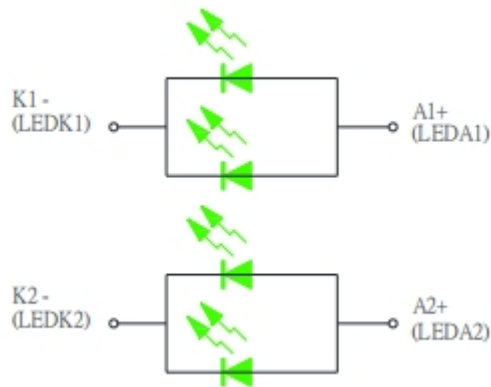

3.2 Timing Characteristic of The LCD

3.2.1 Recommend Operating Conditions and DC Characteristics

Item	Symbol	Min.	Typ.	Max.	Unit	Remark
Frame frequency	fSCS	1	1	20	Hz	Where EXTMODE=Lo
		--	--	20	Hz	Where EXTMODE=Hi
Clock frequency	fSCLK	--	1	2	MHz	
Vertical Interval	tV	50	--	1000	ms	
COM frequency	fCOM	0.5	--	10	Hz	

3.2.2 Input Signal timing Parameters

VDDA=+5.0V、VDD=+5.0V、GND=0V、Ta=25°C

Item	Item	Symbol	Min.	Typ.	Max.	Unit	Remark
SCS	Rise time	trSCS	--	--	50	Ns	
	Fall time	tfSCS	--	--	50	ns	
	High duration	twhSCS	220	--	--	us	Data update mode
			12	--	--	us	Hold mode
	Low duration	twlSCS	1	--	--	us	
	Set up time	tsSCS	3	--	--	us	
	Hold time	thSCS	1	--	--	us	
SI	Rise time	trSI	--	--	50	ns	
	Fall time	trSI	--	--	50	ns	
	Set up time	trSI	120	--	--	ns	
	Hold time	trSI	190	--	--	ns	
SCLK	Rise time	trSCLK	--	--	50	ns	
	Fall time	tfSCLK	--	--	50	ns	
	High duration	twhSCLK	200	450	--	ns	
	Low duration	twlSCLK	200	450	--	ns	
EXTCOMIN	Frequency	fEXTCOMIN	1	1	20	Hz	
	Rise time	trEXTCOMIN	--	--	50	ns	
	Fall time	tfEXTCOMIN	--	--	50	ns	
	High duration	twhEXTCOMIN	1	--	--	us	
DISP	Rise time	trDISP					
	Fall time	tfDISP					

Please make the EXTCOMIN frequency less than the frame rate frequency

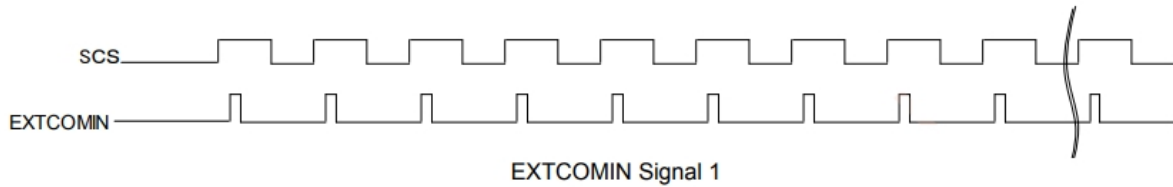

When the display is maintained after writing of the displayed data, is not applied.

(Please keep SCS to "Lo" when you maintain current display after writing of the display data.)

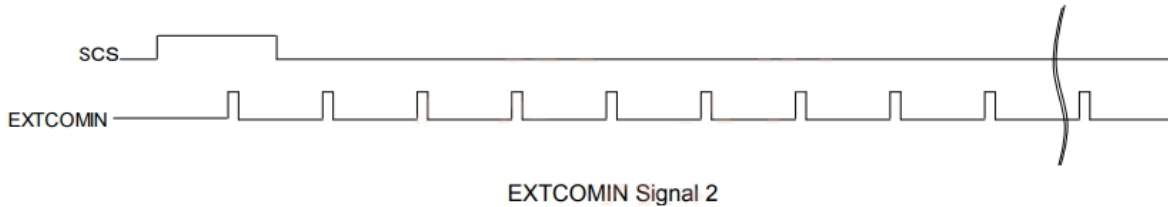

3.2.3 Signal Timing

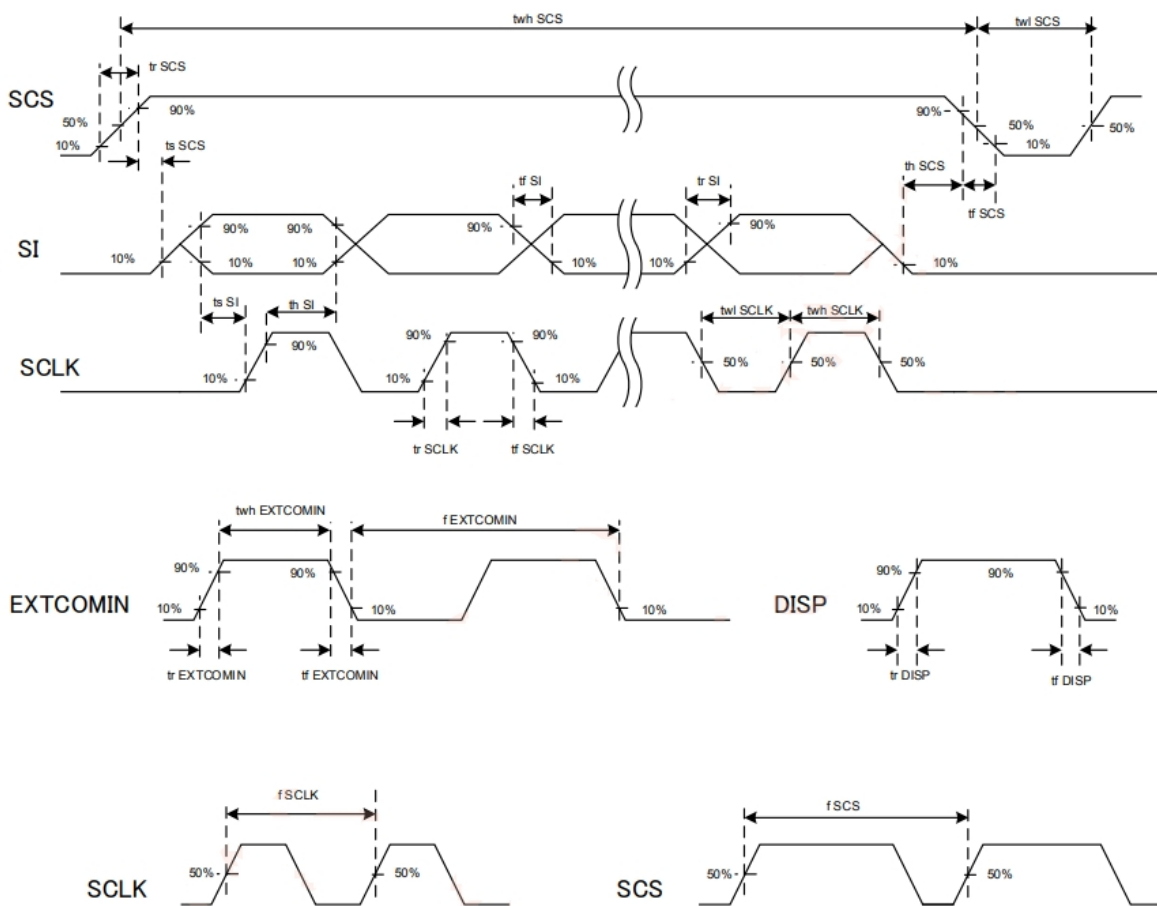

COM signal serial input (EXTMODE="Lo")

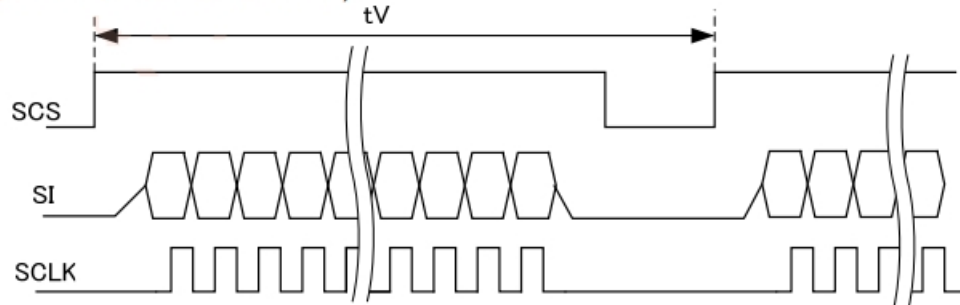

※SCS,SI,SCLK,DISP,EXTCOMIN : 3V input voltage

3.3 Power Consumption

Ta=25°C. EXTCOMIN=+3V, VDD=+5V. VDDA=+5V

Operating Mode	Power consumption	Min.	Typ.	Max.	Unit	Remark
Condition 1	Hold Mode(no display data update Display pattern: Vertical stripe display	--	50	250	μW	(Note 1)
Condition 2	Data Update modewith display update 1Hz(1frarm/sec) Display pattern : Vertical stripe display	--	175	350	μW	(Note 2)

Note 1: After writed Vertical stripe data,set to (SCLK=L0,SCS=L0,SI=L0), It measures during

Note 2: fSCS=1.0Hz, Except in the time of writing, it is set to SCS=L0

4. Optical Characteristics

4.1 Optical characteristic of the LCD

The following items are measured under stable conditions. The optical characteristics should be measured in a dark room or equivalent state with the methods.

Measuring equipment: LCD-5200 / DMS803, CM700d

Item	Symbol	Condition	Min	Type	Max	Unit	Note	
Brightness	B		(TBD)	(25)	--	cd/m ²		
Response Time	Tr	$\theta=0^\circ$	--	10	--	ms		
	Tf		--	20	--	ms		
Contrast Ratio	CR	At optimized viewing angle	--	14	--	--		
Reflection Ratio	R		--	17.5	--	%		
Transmission Ratio	T		--	0.25	--	%		
Color Chromaticity (CIE 1931)	White	x	(TBD)	(0.313)	(TBD)	--	LCD-5200 DMS803	
		y	(TBD)	(0.329)	(TBD)			
Viewing Angle	Hor.	θ_R	$CR \geq 2$	40	55	--	Degree	CM700d
		θ_L		40	55	--		
	Ver.	θ_U		40	60	--		
		θ_D		40	60	--		

a. Test equipment setup

After stabilizing and leaving the panel alone shall be warmed up for the stable operation of LCM, the measurement should be executed. Measurement should be executed in a stable, windless, and dark room. Optical specifications are measured by Topcon BM-7(fast) with a viewing angle of 2° at a distance of 50cm and normal direction.

b. Definition of response time: Tr and Tf

The response time is defined as the following figure and shall be measured by switching the input signal for "black" and "white".

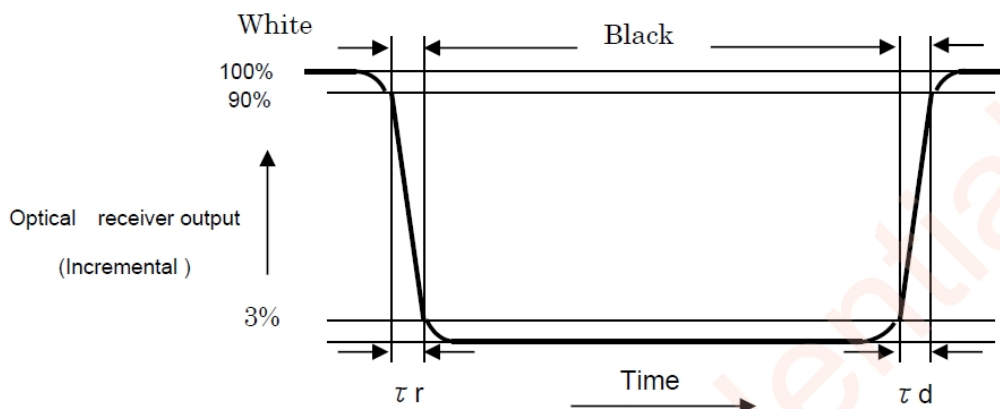

c. Definition of contrast ratio:

$$\text{Contrast Ratio (CR)} = \frac{\text{Brightness measured when LCD is at "white state"}}{\text{Brightness measured when LCD is at "black state"}}$$

d. Measured at the center area of the panel when all the input terminals of LCD panel are electrically opened.

e. View Angle

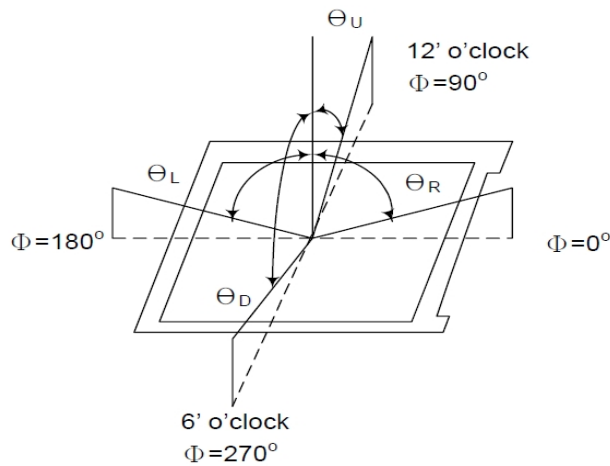

f. Definition of Luminance of White: Luminance of white at the center points

Light Source of Back-Light Unit	LED Type
---------------------------------	----------

g. Definition of White Uniformity

$$\text{White Uniformity} = \frac{\text{Min. luminance of white among 9-points}}{\text{Max. luminance of white among 9-points}} \times 100\%$$

h. The definition of Color Gamut -Color Chromaticity CIE 1931

Color coordinate of white & red, green, blue at center point.

Color Gamut : NTSC(%) = (RGB Triangle Area / NTSC Triangle Area) x 100

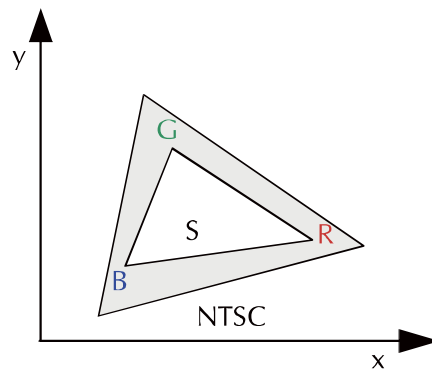

5. I/O Terminal

5.1 Pin Assignment (LCD)

Recommended Connector : AYF531035 (Panasonic) or FH34SRJ-10-0.5SH(HRS) or compatible

Pin No.	Symbol	I/O	Function	Remark
1	SCLK	I	Serial clock signal	
2	SI	I	Serial input signal	
3	SCS	I	Chip select signal	
4	EXTCOMIN	I	COM inversion polarity input pin	
5	DISP	I	Display ON / OFF switching signal	
6	VDDA	P	Power Source for Analog	
7	VDD	P	Power Source for Logic	
8	EXTMODE	I	COM inversion mode switch terminal	
9	VSS	P	Logic ground	
10	VSSA	P	Analogue ground	

Notes:

- 1) NC Pin must be retained; this pin cannot contact GND or other signal.
- 2) GND Pin must ground contact, cannot be floating.

5.2 Pin Assignment (Backlight)

Recommended Connector : Molex 5052780670 or compatible

Pin No.	Symbol	I/O	Function	Remark
1	A+	P	LED Anode	
2	A+	P	LED Anode	
3	NC	-	Not Connect	
4	NC	-	Not Connect	
5	K-	P	LED Cathode	
6	K-	P	LED Cathode	

5.3 Block Diagram

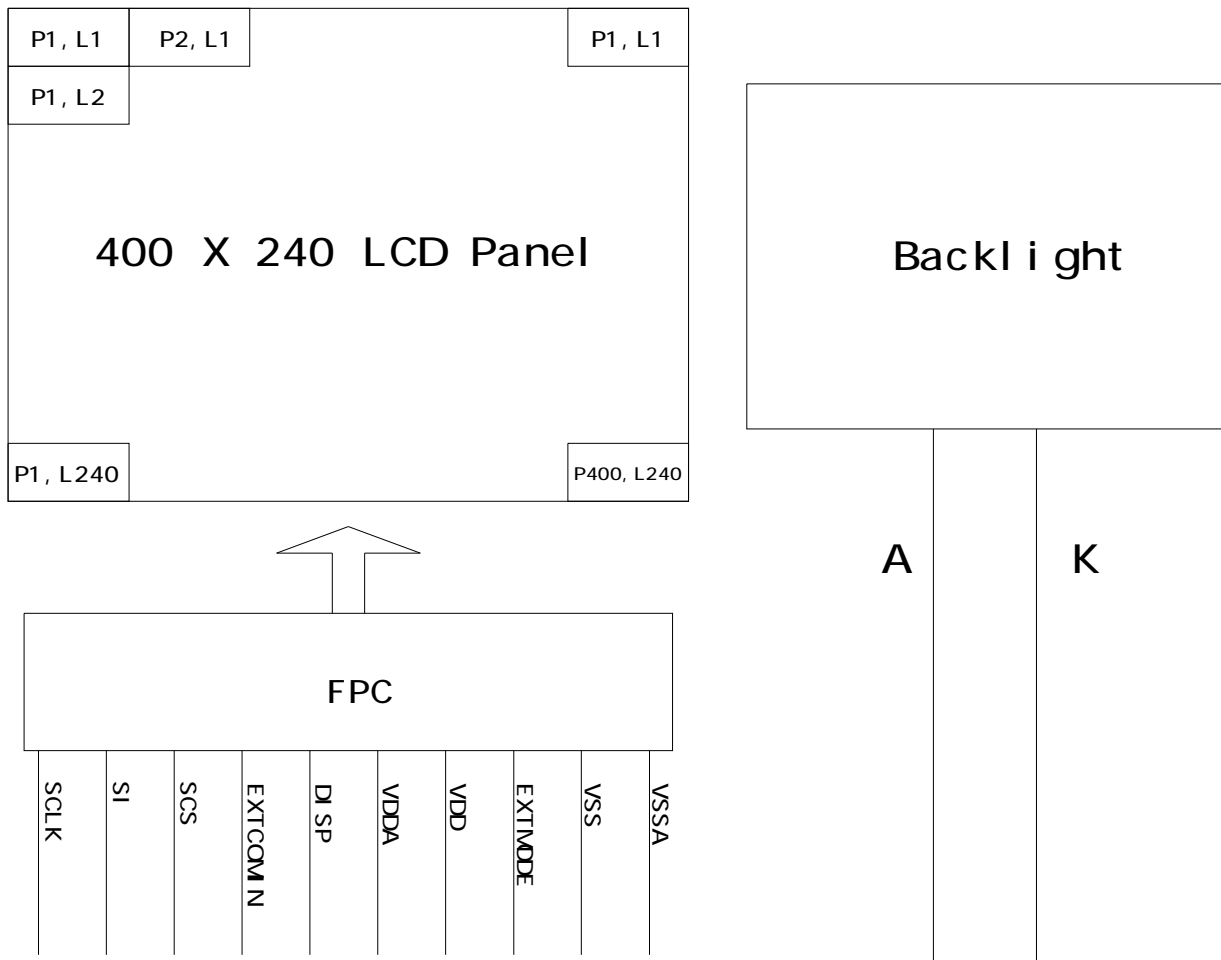

6. Displayed Color and Input Data

GL	AG0	AG1	AG2	AG3	AG4	AG5	AG6	AG7
1	1	0	0	0	0	0	0	0
2	0	1	0	0	0	0	0	0
3	1	1	0	0	0	0	0	0
4	0	0	1	0	0	0	0	0
5	1	0	1	0	0	0	0	0
6	0	1	1	0	0	0	0	0
7	1	1	1	0	0	0	0	0
8	0	0	0	1	0	0	0	0
9	1	0	0	1	0	0	0	0
10	0	1	0	1	0	0	0	0
11	1	1	0	1	0	0	0	0
12	0	0	1	1	0	0	0	0
13	1	0	1	1	0	0	0	0
14	0	1	1	1	0	0	0	0
15	1	1	1	1	0	0	0	0
16	0	0	0	0	1	0	0	0
17	1	0	0	0	1	0	0	0
18	0	1	0	0	1	0	0	0
19	1	1	0	0	1	0	0	0
20	0	0	1	0	1	0	0	0

GL	AG0	AG1	AG2	AG3	AG4	AG5	AG6	AG7
21	1	0	1	0	1	0	0	0
22	0	1	1	0	1	0	0	0
23	1	1	1	0	1	0	0	0
24	0	0	0	1	1	0	0	0
25	1	0	0	1	1	0	0	0
26	0	1	0	1	1	0	0	0
27	1	1	0	1	1	0	0	0
28	0	0	1	1	1	0	0	0
29	1	0	1	1	1	0	0	0
30	0	1	1	1	1	0	0	0
31	1	1	1	1	1	0	0	0
32	0	0	0	0	0	1	0	0
33	1	0	0	0	0	1	0	0
34	0	1	0	0	0	1	0	0
35	1	1	0	0	0	1	0	0
36	0	0	1	0	0	1	0	0
37	1	0	1	0	0	1	0	0
38	0	1	1	0	0	1	0	0
39	1	1	1	0	0	1	0	0
40	0	0	0	1	0	1	0	0

GL	AG0	AG1	AG2	AG3	AG4	AG5	AG6	AG7
41	1	0	0	1	0	1	0	0
42	0	1	0	1	0	1	0	0
43	1	1	0	1	0	1	0	0
44	0	0	1	1	0	1	0	0
45	1	0	1	1	0	1	0	0
46	0	1	1	1	0	1	0	0
47	1	1	1	1	0	1	0	0
48	0	0	0	0	1	1	0	0
49	1	0	0	0	1	1	0	0
50	0	1	0	0	1	1	0	0
51	1	1	0	0	1	1	0	0
52	0	0	1	0	1	1	0	0
53	1	0	1	0	1	1	0	0
54	0	1	1	0	1	1	0	0
55	1	1	1	0	1	1	0	0
56	0	0	0	1	1	1	0	0
57	1	0	0	1	1	1	0	0
58	0	1	0	1	1	1	0	0
59	1	1	0	1	1	1	0	0
60	0	0	1	1	1	1	0	0

GL	AG0	AG1	AG2	AG3	AG4	AG5	AG6	AG7
61	1	0	1	1	1	1	0	0
62	0	1	1	1	1	1	0	0
63	1	1	1	1	1	1	0	0
64	0	0	0	0	0	0	1	0
65	1	0	0	0	0	0	1	0
66	0	1	0	0	0	0	1	0
67	1	1	0	0	0	0	1	0
68	0	0	1	0	0	0	1	0
69	1	0	1	0	0	0	1	0
70	0	1	1	0	0	0	1	0
71	1	1	1	0	0	0	1	0
72	0	0	0	1	0	0	1	0
73	1	0	0	1	0	0	1	0
74	0	1	0	1	0	0	1	0
75	1	1	0	1	0	0	1	0
76	0	0	1	1	0	0	1	0
77	1	0	1	1	0	0	1	0
78	0	1	1	1	0	0	1	0
79	1	1	1	1	0	0	1	0
80	0	0	0	0	1	0	1	0
81	1	0	0	0	1	0	1	0
82	0	1	0	0	1	0	1	0
83	1	1	0	0	1	0	1	0
84	0	0	1	0	1	0	1	0
85	1	0	1	0	1	0	1	0
86	0	1	1	0	1	0	1	0
87	1	1	1	0	1	0	1	0
88	0	0	0	1	1	0	1	0
89	1	0	0	1	1	0	1	0
90	0	1	0	1	1	0	1	0
91	1	1	0	1	1	0	1	0
92	0	0	1	1	1	0	1	0
93	1	0	1	1	1	0	1	0
94	0	1	1	1	1	0	1	0
95	1	1	1	1	1	0	1	0
96	0	0	0	0	0	1	1	0
97	1	0	0	0	0	1	1	0
98	0	1	0	0	0	1	1	0
99	1	1	0	0	0	1	1	0
100	0	0	1	0	0	1	1	0
101	1	0	1	0	0	1	1	0
102	0	1	1	0	0	1	1	0
103	1	1	1	0	0	1	1	0
104	0	0	0	1	0	1	1	0
105	1	0	0	1	0	1	1	0
106	0	1	0	1	0	1	1	0
107	1	1	0	1	0	1	1	0
108	0	0	1	1	0	1	1	0
109	1	0	1	1	0	1	1	0
110	0	1	1	1	0	1	1	0
111	1	1	1	1	0	1	1	0
112	0	0	0	0	1	1	1	0
113	1	0	0	0	1	1	1	0
114	0	1	0	0	1	1	1	0
115	1	1	0	0	1	1	1	0
116	0	0	1	0	1	1	1	0
117	1	0	1	0	1	1	1	0
118	0	1	1	0	1	1	1	0
119	1	1	1	0	1	1	1	0
120	0	0	0	1	1	1	1	0

GL	AG0	AG1	AG2	AG3	AG4	AG5	AG6	AG7
121	1	0	0	1	1	1	1	0
122	0	1	0	1	1	1	1	0
123	1	1	0	1	1	1	1	0
124	0	0	1	1	1	1	1	0
125	1	0	1	1	1	1	1	0
126	0	1	1	1	1	1	1	0
127	1	1	1	1	1	1	1	0
128	0	0	0	0	0	0	0	1
129	1	0	0	0	0	0	0	1
130	0	1	0	0	0	0	0	1
131	1	1	0	0	0	0	0	1
132	0	0	1	0	0	0	0	1
133	1	0	1	0	0	0	0	1
134	0	1	1	0	0	0	0	1
135	1	1	1	0	0	0	0	1
136	0	0	1	0	0	0	0	1
137	1	0	0	1	0	0	0	1
138	0	1	0	1	0	0	0	1
139	1	1	0	1	0	0	0	1
140	0	0	1	1	0	0	0	1
141	1	0	1	1	0	0	0	1
142	0	1	1	1	0	0	0	1
143	1	1	1	1	0	0	0	1
144	0	0	0	0	1	0	0	1
145	1	0	0	0	1	0	0	1
146	0	1	0	0	1	0	0	1
147	1	1	0	0	1	0	0	1
148	0	0	1	0	1	0	0	1
149	1	0	1	0	1	0	0	1
150	0	1	1	0	1	0	0	1
151	1	1	1	0	1	0	0	1
152	0	0	0	1	1	0	0	1
153	1	0	0	1	1	0	0	1
154	0	1	0	1	1	0	0	1
155	1	1	0	1	1	0	0	1
156	0	0	1	1	1	0	0	1
157	1	0	1	1	1	0	0	1
158	0	1	1	1	1	0	0	1
159	1	1	1	1	1	0	0	1
160	0	0	0	0	0	1	0	1
161	1	0	0	0	0	1	0	1
162	0	1	0	0	0	1	0	1
163	1	1	0	0	0	1	0	1
164	0	0	1	0	0	1	0	1
165	1	0	1	0	0	1	0	1
166	0	1	1	0	0	1	0	1
167	1	1	1	0	0	1	0	1
168	0	0	0	1	0	1	0	1
169	1	0	0	1	0	1	0	1
170	0	1	0	1	0	1	0	1
171	1	1	0	1	0	1	0	1
172	0	0	1	1	0	1	0	1
173	1	0	1	1	0	1	0	1
174	0	1	1	1	0	1	0	1
175	1	1	1	1	0	1	0	1
176	0	0	0	0	1	1	0	1
177	1	0	0	0	1	1	0	1
178	0	1	0	0	1	1	0	1
179	1	1	0	0	1	1	0	1
180	0	0	1	0	1	1	0	1

GL	AG0	AG1	AG2	AG3	AG4	AG5	AG6	AG7
181	1	0	1	0	1	1	0	1
182	0	1	1	0	1	1	0	1
183	1	1	1	0	1	1	0	1
184	0	0	0	1	1	1	0	1
185	1	0	0	1	1	1	0	1
186	0	1	0	1	1	1	0	1
187	1	1	0	1	1	1	0	1
188	0	0	1	1	1	1	0	1
189	1	0	1	1	1	1	0	1
190	0	1	1	1	1	1</		

7. Reliability Condition

No change on display and in operation under the following test condition.

Condition: Unless otherwise specified, tests will be conducted under the following condition.

Temperature: 20°C±5°C.

Humidity: 65%±5% RH.

Tests will be not conducted under functioning state.

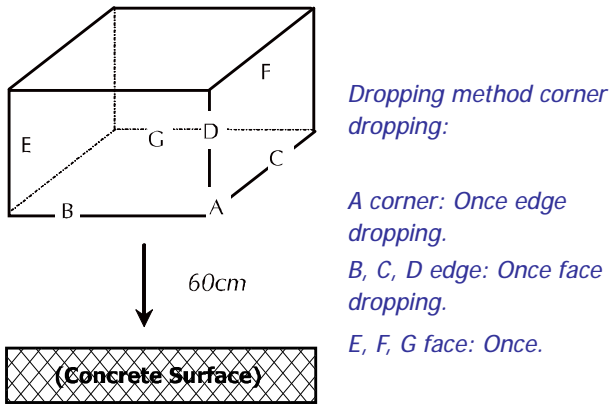
No.	Parameter	Condition	Notes
1	High Temperature Operating	+70°C±2°C, 240hrs (Operation state).	
2	Low Temperature Operating	-20°C±2°C, 240hrs (Operation state).	1
3	High Temperature Storage	+80°C, 240hrs.	2
4	Low Temperature Storage	-30°C±2°C, 240hrs.	1,2
5	High Temperature and High Humidity Storage Test	60°C±2°C, 90%, 240hrs.	1,2
6	Vibration Test	Total fixed amplitude: 1.5mm. Vibration Frequency: 10~55Hz. One cycle 60 seconds to 3 direction of X, Y, Z each 15 minutes.	3
7.	Drop Test	To be measured after dropping from 60cm high on the concrete surface in packing state.  <i>Dropping method corner dropping:</i> <i>A corner: Once edge dropping.</i> <i>B, C, D edge: Once face dropping.</i> <i>E, F, G face: Once.</i>	

- Notes:
1. No dew condensation to be observed.
 2. The function test shall be conducted after 4 hours storage at the normal temperature and humidity after removed from the test chamber.
 3. Vibration test will be conducted to the product itself without putting I in a container.

8. Dimensional Outlines

NO.	Pin Define
1	SCLK
2	SI
3	SCS
4	EXTCOMV
5	DSP
6	VDDA
7	VDD
8	EXTMODE
9	VSS
10	VSSA

Pin	Assignment
1	A1
2	A2
3	NC
4	NC
5	K1
6	K2

BACK VIEW

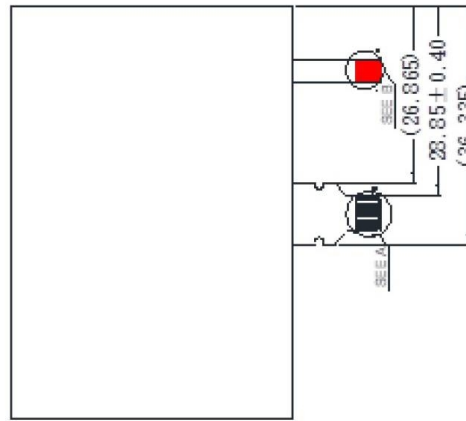

SIDE VIEW



FRONT VIEW

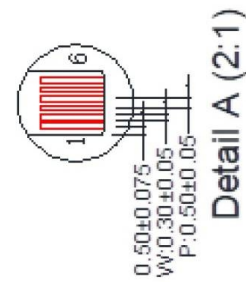
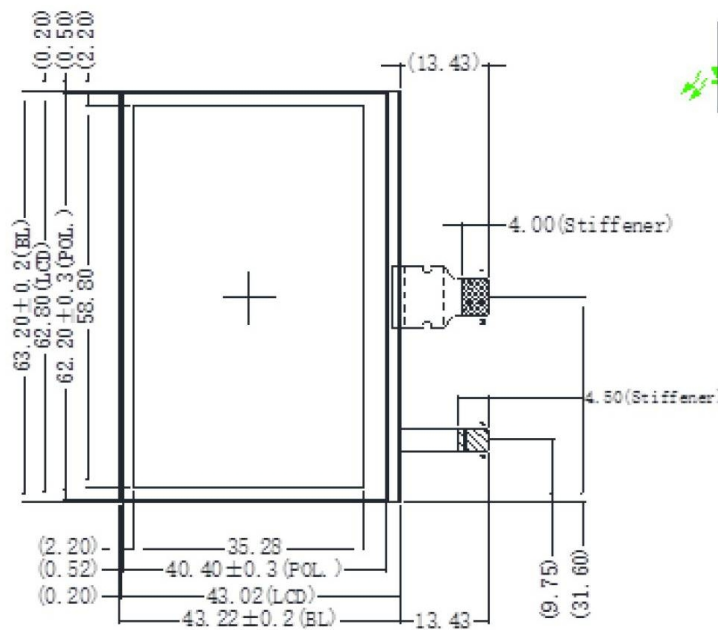

Detail A (2:1)

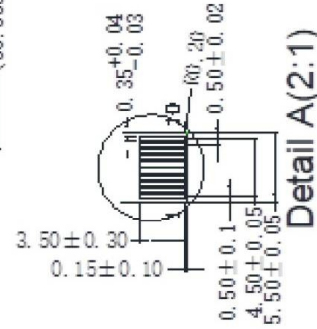

Detail A(2:1)

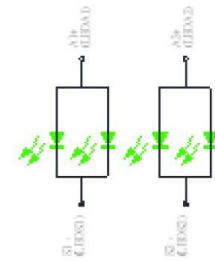

LEDS
1S4P
Vf=3V(Typ.)
If=20*4=80mA

- NOTES:
1. OPERATING TEMP: -20°C~+70°C
 2. STORAGE TEMP: -30°C~+80°C
 3. BACKLIGHT: WHITE
 4. Brightness : TBD
 5. General tolerance is ±0.2

APPEXNDIX 1. Inspection and Environment Conditions

1.1 Inspection Conditions:

(1)/Inspection Distance: 35 cm±5cm

(2)/ View Angle:

Light-on Inspection Angle : ±5°

Cosmetic Inspection Angle : ±45°

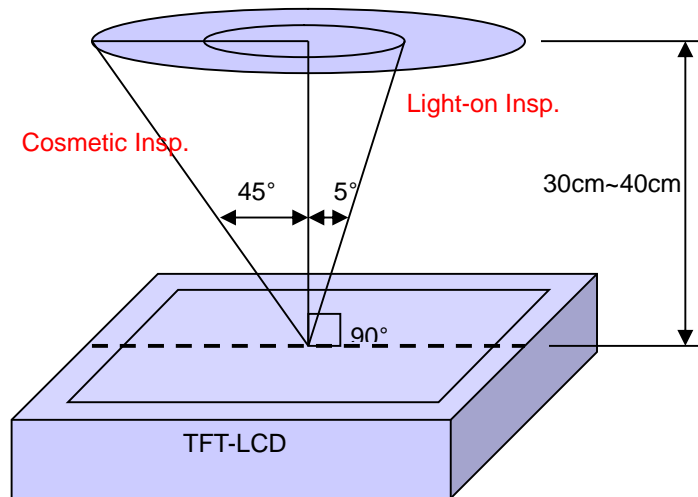

(perpendicular to LCD panel surface)

1.2/Environment Conditions:

/ Ambient Temperature		23°C±5°C
/ Ambient Humidity		55±10%RH
Ambient Illumination	Cosmetic Inspection	more than 600 Lux
	Functional Inspection	300~500 Lux

1.3 /Sampling Conditions:

- (1) Lot Size: Quantity of shipment lot per model
- (2)/Sampling Method:

Sampling Plan		MIL-STD-105E
		Normal Inspection, Single Sampling
		Level II
AQL	Major Defect	1.0%
	Minor Defect	1.5%

(3)(MA)(MI3

The classification of Major(MA) and Minor(MI) defects is shown as 3. Inspection Criteria.

2. Inspection Criteria

2.1 Cosmetic Inspection(Panel):

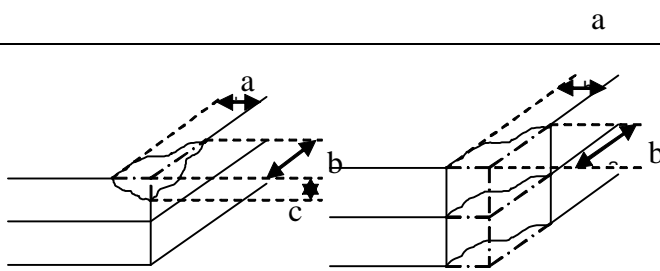
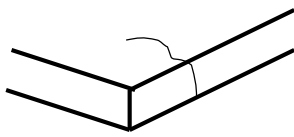
Item	Judgment Criteria	分類/ Classification
Chipping on Panel	 <p>$a \leq 3.0\text{mm}$, $b \leq 3.0\text{mm}$, $c \leq t$ (Bottom glass thickness)</p>	MA
Scratch on Panel *Note-2	<p>1.BM: Ignored 2.Pixel area $W \leq 0.05\text{mm}$ or $L < 5\text{mm}$: Ignored/不計 $0.05\text{mm} < W \leq 0.1\text{mm}$ and $L \leq 5\text{mm}$: $N \leq 5$ $W > 0.1\text{mm}$ or $L > 5\text{mm}$: Not allowed/不允許</p>	MI
Bubble or Dent on Panel/Touch Panel *Note-3	<p>1.BM: Ignored 2.Pixel area $D \leq 0.2\text{mm}$: Ignored/ $0.2\text{mm} < D \leq 0.3\text{mm}$: $N \leq 5$ $D > 0.3\text{mm}$: Not allowed/</p>	MI
Panel Crack	 <p>Not Allowed crack</p>	MA
Bezel Deformation	Obvious deformation is not allowed.	MI
Bezel Oxidation	Not allowed if it rusts continuously over 1 cm (lt	MI

	is out of warranty with rusted tin plate)	
Bezel Scratch	$L \leq 20\text{mm}$, $W \leq 0.2$, $N \leq 3$	MI
Metal Squash Dent /Flange(Front Side)	$D(W) \leq 1, L \leq 3, N \leq 3;$	MI
B/L High Voltage Wire Denudation	Not allowed	MA
Polarizer flaw or leak out resin	Defect is defined as the active area.	MI
Outline Dimension	Product Spec. Must in Spec, refer to related product spec.	MI

2.2 Functional Inspection:

Item	Judgment Criteria			Classification
	Area(Note1)	I	O	
Point Defect	Bright dot	Random	$N \leq 5$	MI
		2dots adjacent	$N \leq 1$	
		3 dots adjacent or more	$N \leq 0$	
	Dark dot	Random	$N \leq 5$	
		2dots adjacent	$N \leq 1$	
		3 dots adjacent or more	$N \leq 0$	
	Total Bright dot and Dark dot		$N \leq 5$	
	Distance	Distance between Bright and Bright dot	$L \geq 5\text{mm}$	
		Distance between Bright and Dark dot	$L \geq 5\text{mm}$	
		Distance between Dark dot	$L \geq 5\text{mm}$	
(1)>0.5dot It is defined as Point Defect if defect area > 0.5dot (2) $\leq 0.5\text{dot}$ It is ignored if defect area $\leq 0.5\text{dot}$ (3)ND Filter 5% Weak point defect will be defined as Bright Dot if it can be observed through ND filter 5%(Full Screen Black Inspection)				

Line Defect	Obvious vertical or horizontal line defect is not allowed.	MA
Mura	ND Filter 5 % Mura Not allowed if it can be observed through ND Filter 5 %	MI
Foreign Material in spot shape *Note-3	Visible under : ND5% D \leq 0.15mm: Ignored 0.15mm<D \leq 0.5mm: N \leq 5 D>0.5mm: Not allowed	MI
Foreign Material in line or spiral shape *Note-4	Visible under : ND5% W \leq 0.05mm or L \leq 5mm: Ignored 0.05mm<W \leq 0.2mm and L 1.0mm<L \leq 5.0mm: N \leq 5 W>0.2mm or L>5.0mm: Not allowed	MI
Display Function Abnormal	No Malfunction can be allowed	MA

Note-1 : I/O I/OArea Definition

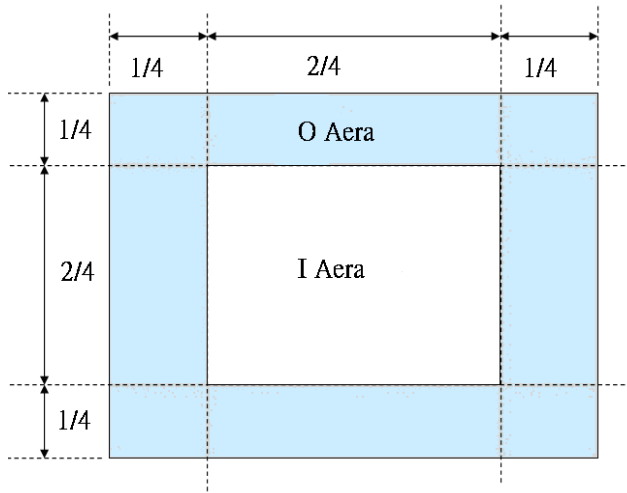

Note-2 : Polarizer Polarizer Scratch

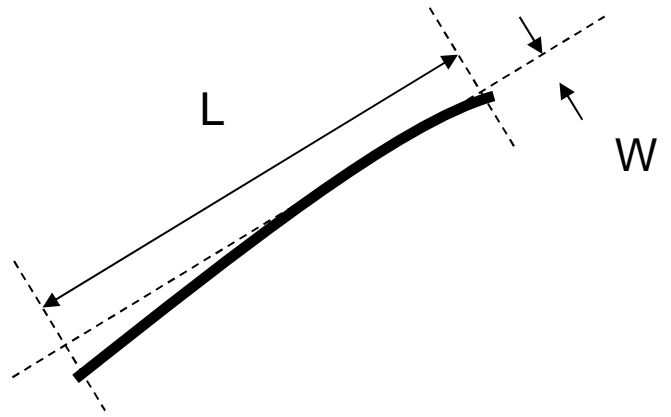

Note-3 : Spot Foreign Material

$$(W \geq L / 4)$$

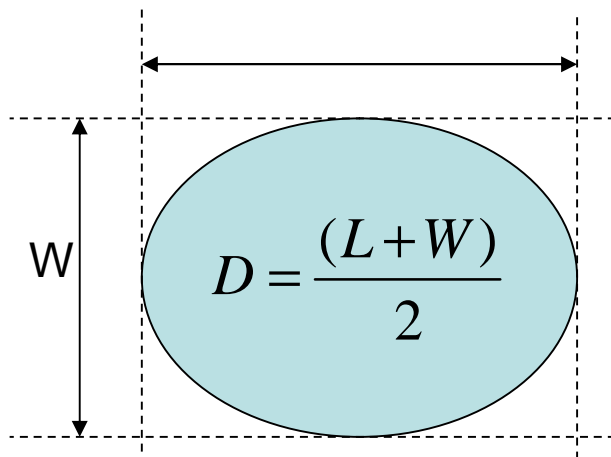

Note-4 : Line or Spiral Foreign Material

$$(W < L / 4)$$

