

Display Elektronik GmbH

DATA SHEET

MIP Display

DE MIP240320A-RGB

Product Specification

Ver.: 0

13.12.2023

Revise Records

Rev.	Date	Contents	Written	Approved
0	13.12.2023	Preliminary Specification	J	O

Special Notes

Note1.	
Note2.	
Note3.	
Note4.	
Note5.	

Contents

1.General Description and Features	4
1.1 Features	4
1.2 LCD Module	4
2. Mechanical Information	4
3. Electrical Specifications	5
3.1 Absolute Max. Ratings	5
3.2 Timing Characteristic of The LCD	6
3.3 Power Supply Sequence	15
4. Optical Characteristics	17
4.1 Optical characteristic of the LCD	17
5. I/O Terminal	19
5.1 LCM Pin define	19
5.2 Block Diagram	21
6. Reliability Condition	22
7. Dimensional Outlines	23

1. General Description and Features

DE MIP 240320A RGB - 64-Color LCD module is a reflective active-matrix with slightly transmissive memory liquid crystal display module with CG silicone thin film transistor.

1.1 Features

- Reflective active-matrix with slightly transmissive panel of Color.
- 2.13" screen has 240 x 320 Resolution.
- Display control by 6 bit parallel data signal communication.
- 1 pixel has RGB each 2bit · the pixel can display 64 colors.
- Super low power consumption TFT panel.

1.2 LCD Module

Item	Specification	Unit
Screen Size	2.13 Inches	Diagonal
Display Resolution	240 x RGB x 320	Dot
Active Area	32.40 x 43.20	mm
Outline Dimension	35.40 x 48.60 0.91	mm
Display Mode	Memory in Pixel Normally Black	--
Pixel Arrangement	Stripe Array	--
Dot Pitch	0.135 x 0.135	mm
Surface treatment	Hard Coated	--

2. Mechanical Information

Item		Min.	Typ.	Max.	Unit	Note
Module Size	Horizontal (H)	--	35.40	--	mm	--
	Vertical (V)	--	48.60	--	mm	--
	Thickness (T)	--	0.91	--	mm	(1)
Weight		--	3.5	--	g	--

Note (1) Not Include Component. Refer to the Outline Dimension Drawing as attached.

3. Electrical Specifications

3.1 Absolute Max. Ratings

3.1.1 Absolute Ratings of Environment

If the operating condition exceeds the following absolute maximum ratings, the TFT LCD module may be damaged permanently.

(Ta=25±2°C, V_{SS}=GND=0)

Item	Symbol	Min.	Max.	Unit	Note
Storage Temperature	T _{STG}	-30	80	°C	(1)
Operating Temperature	T _{OPR}	-20	70	°C	(1,2,3)

Note (1) 95 % RH Max. (40°C ≥ Ta). Maximum wet-bulb temperature at 39°C or less. (Ta > 40°C)
No condensation.

Note (2) In case of below 0°C, the response time of liquid crystal (LC) becomes slower and the color of panel becomes darker than normal one. Level of retardation depends on temperature, because of LC's character

Note (3) Only operation is guaranteed at operating temperature. Contrast, response time, another display quality are evaluated at +25°C.

3.1.2 Electrical Absolute Maximum Ratings

3.1.2.1 TFT-LCD Module

Parameter	Symbol	Min.	Max.	Unit	Remark	
Power Supply Voltage	V_VDD1	VDD1	-0.3	5.5	V	--
	V_VDD2	VDD2	-0.3	5.5	V	--
	V_VSS	VSS	0	0	V	--
Input Signal Voltage	High Level	V _{IH}	--	V_VDD1	V	--
	Low Level	V _{IL}	-0.3	--	V	--
VCOM,VA,VB Terminal Voltage	High Level	V _{H_VCOM}	--	3.4	V	--
	Low Level	V _{L_VCOM}	-0.3	--	V	--

3.1.3 DC Electrical Characteristics of the TFT LCD

Parameter	Symbol	Min.	Typ	Max.	Unit	Remark	
Power Supply Voltage	V_VDD1	VDD1	3.1	3.2	3.3	V	--
	V_VDD2	VDD2	4.85	5.0	5.15	V	--
	V_VSS	VSS	0	0	0	V	--
Input Signal Voltage	High Level	VIH	VDD1-0.1	3.2	VDD1	V	--
	Low Level	VIL	VSS	0	VSS+0.1	V	--
VCOM,VA,VB Terminal Voltage	High Level	VH_VCOM	VDD1-0.1	3.2	VDD1	V	Note 1-1
	Low Level	VL_VCOM	VSS	0	VSS+0.1	V	Note 1-2

[General Note]

Above Voltage value is a value based on VSS (GND = 0V)

Note 1-1 :

VB is in-phase with VCOM. VA is opposite-phase to VCOM.

Please design not to be occurred deviation of Center voltage / Signal timing.

VB is the same signal as VCOM and VA is the inverse signal of VCOM and VB

Note 1-2 :

The Hight Level of VA/VB/VCOM must be below VDD1 voltage.

Operating Mode	Power consumption	Min	Typ	Max	unit	Remark
Condition 1	Hold mode(no display data update) Display pattern : White display	-	32	279	μ W	[Note 6-7-1]
Condition 2	Data update modewith display update 1Hz (1fram/sec) Display pattern : White display	-	45	295	μ W	[Note 6-7-2]
Condition 3	Data update modewith display update (18)Hz (18fram/sec) Display pattern : White display	-	290	695	μ W	[Note 6-7-3]

Common condition

VDD1=3.2V, VDD2=5.0V, VCOMH=VDD1,VCOML=0V(GND), fVCOM= (60Hz)

The contents of VCOM, VA, and VB terminals(Equivalent circuit Charge to capacitor,Discharge current) in Table 6-7-2 are not included in the current consumption in Table 6-7-1.

[Note 6-7-1], [Note 6-7-2] [Note 6-7-3]

Power consumption expenditure of module

$$(I_{vdd1} (\mu A) \times 3.2V) + (I_{vdd2} (\mu A) \times 5.0V)$$

(Common Note)

This is value in average, not the falue of peak power at the time of data-update operation.

Some marging for power supply is recommended.

We recommend capacitor for VDD1 and VDD2.

VDD1=3.2V, VDD2=5.0V, VSS(GND)=0V, Ta=25°C

Item	Symbol	Min	Typ	Max	Unit	Remark
1frame frequency	fV	—	18	18.9	Hz	
vertical period	tV	53	55.6	—	msec	

3.2.2 AC Characteristics (1)

VDD1=3.2V, VDD2=5.0V, VSS=(GND)=0V, Ta=25°C

Signal	Item	Symbol	Min	Typ	Max	Unit	Remark
INTB	Rising time	trINTB	—	—	50	ns	
	Falling time	tfINTB	—	—	50	ns	
	Pulse width Hight level	thwINTB	52.87	53.67	54.47	ms	
	Pulse width Low level	tlwINTB	163.68	166.16	168.64	μs	
	Setup time (Hight level)	thsINTB	20.46	20.77	21.08	μs	INTB to GSP
	Hold time (Hight level)	thhINTB	265.98	270.01	274.04	μs	GCK(643) to INTB
	Hold time (Low level)	tlhINTB	20.46	20.77	21.08	μs	GCK(647) to INTB
GSP	Rising time	trGSP	—	—	50	ns	
	Falling time	tfGSP	—	—	50	ns	
	Setup time Hight level	thsGSP	40.92	41.54	42.16	μs	
	Setup time Low level	tlsGSP	40.92	41.54	42.16	μs	
GCK	Rising time	trGCK	—	—	50	ns	
	Falling time	tfGCK	—	—	50	ns	
	Setup time 2	tsGCK2	0	(335)	—	ns	GCK to BSP
	Setup time1	tsGCK1	16.37	—	—	μs	GCK to GEN
	Hold time1	thGCK1	16.37	—	—	μs	GCK to GEN
	GCK width Hight level	thwGCK	81.84	83.08	84.32	μs	Duty 50%
			1.0	—	—	μs	Note 6-3-1 Duty 50%
	GCK width Low level	tlwGCK	81.84	83.08	84.32	μs	Duty 50%
1.0			—	—	μs	Note 6-3-1 Duty 50%	
GEN	Rising time	trGEN	—	—	50	ns	
	Falling time	tfGEN	—	—	50	ns	
	Pulse width Hight level	thwGEN	24.56	—	—	μs	

Note 6-3-1 : Partial Update mode (non-updated timing) [Fast forward GCK]

3.2.3 AC Characteristics (2)

VDD1=3.2V, VDD2=5.0V, VSS=0V, Ta=25°C

Signal	Item	Symbol	Min	Typ	Max	Unit	Remark
VCOM VA VB	VCOM frequency	fVCOM	54	60	66	Hz	Note 6-3-2 Duty 50%
	Rising time	trVCOM	—	—	100	μs	
	Falling time	tfVCOM	—	—	100	μs	
	(Duty cycle)	(tdyVCOM)	48	50	52	%	
BSP	Rising time	trBSP	—	—	50	ns	
	Falling time	tfBSP	—	—	50	ns	
	Setup time Hight level	thsBSP	330	335	340	ns	BSP to BCK
	Setup time Low level	tlsBSP	330	335	340	ns	BSP to BCK
BCK	Rising time	trBCK	—	—	50	ns	
	Falling time	thBCK	—	—	50	ns	
	BCK frequency	fBCK	—	0.746	0.758	MHz	Duty 50%
	BCK width Hight level	thwBCK	660	670	680	ns	Duty 50%
	BCK width Low level	tlwBCK	660	670	680	ns	Duty 50%
DATA R [0].R[1] G [0].R[1] B [0].R[1]	Rising time	trRGB	—	—	50	ns	
	Falling time	tfRGB	—	—	50	ns	
	Data set-up time	tsRGB	330	335	340	ns	
	Data hold time	thRGB	330	335	340	ns	

Note 6-3-2 : When the VCOM,VA and VB frequency are slower ,the flicker might be seen.

Please evaluate sufficienth when determing the VCOM,VA and VB frequency.

Signal Timing

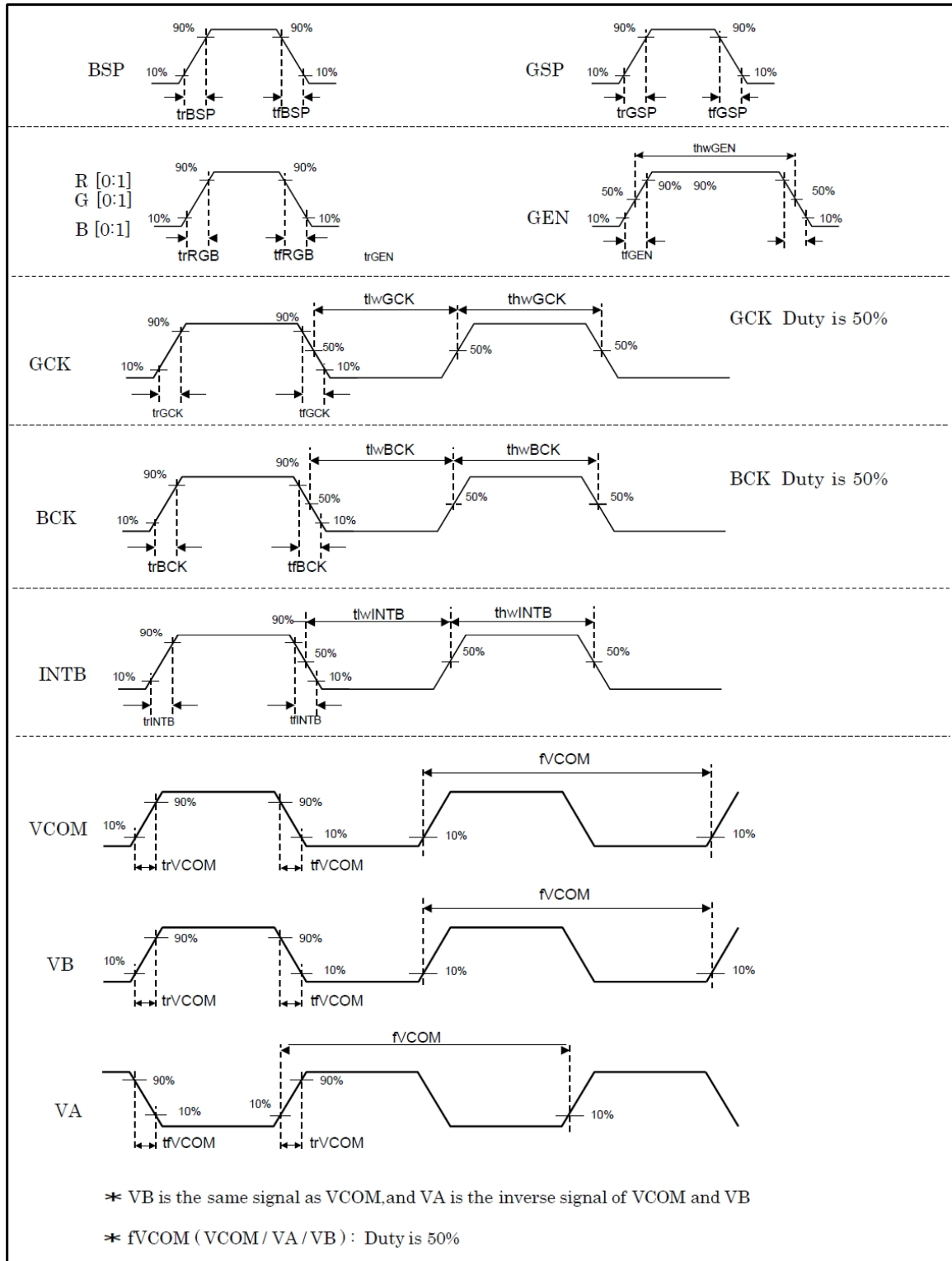
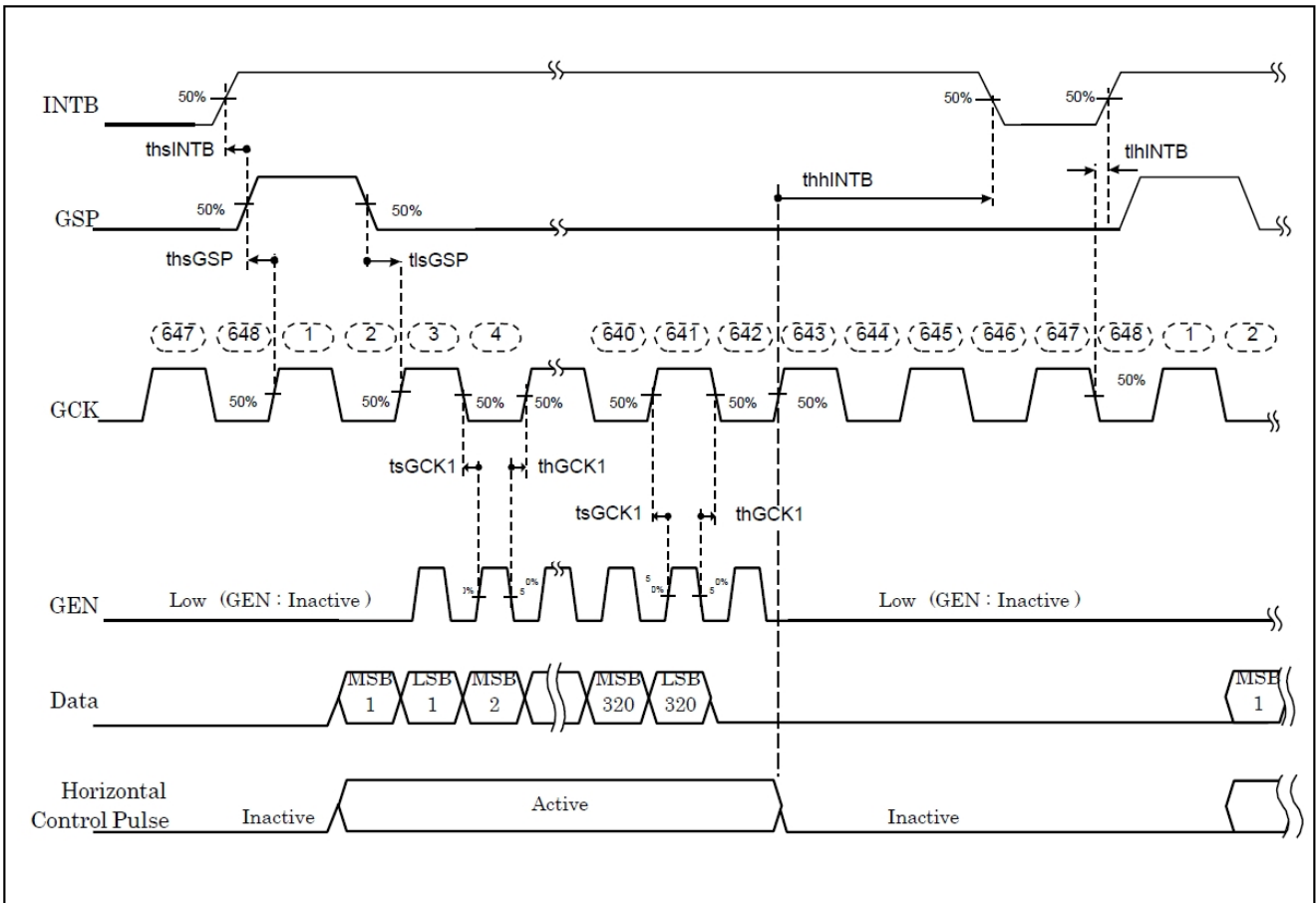

Figure : AC Timing 1

Vertical Signal Timing



GCK Duty is 50%
 Data : R[0],R[1],G[0],G[1],B[0],B[1]
 Horizontal Control Pulse : BCK,BSP

Figure : AC Timing 2

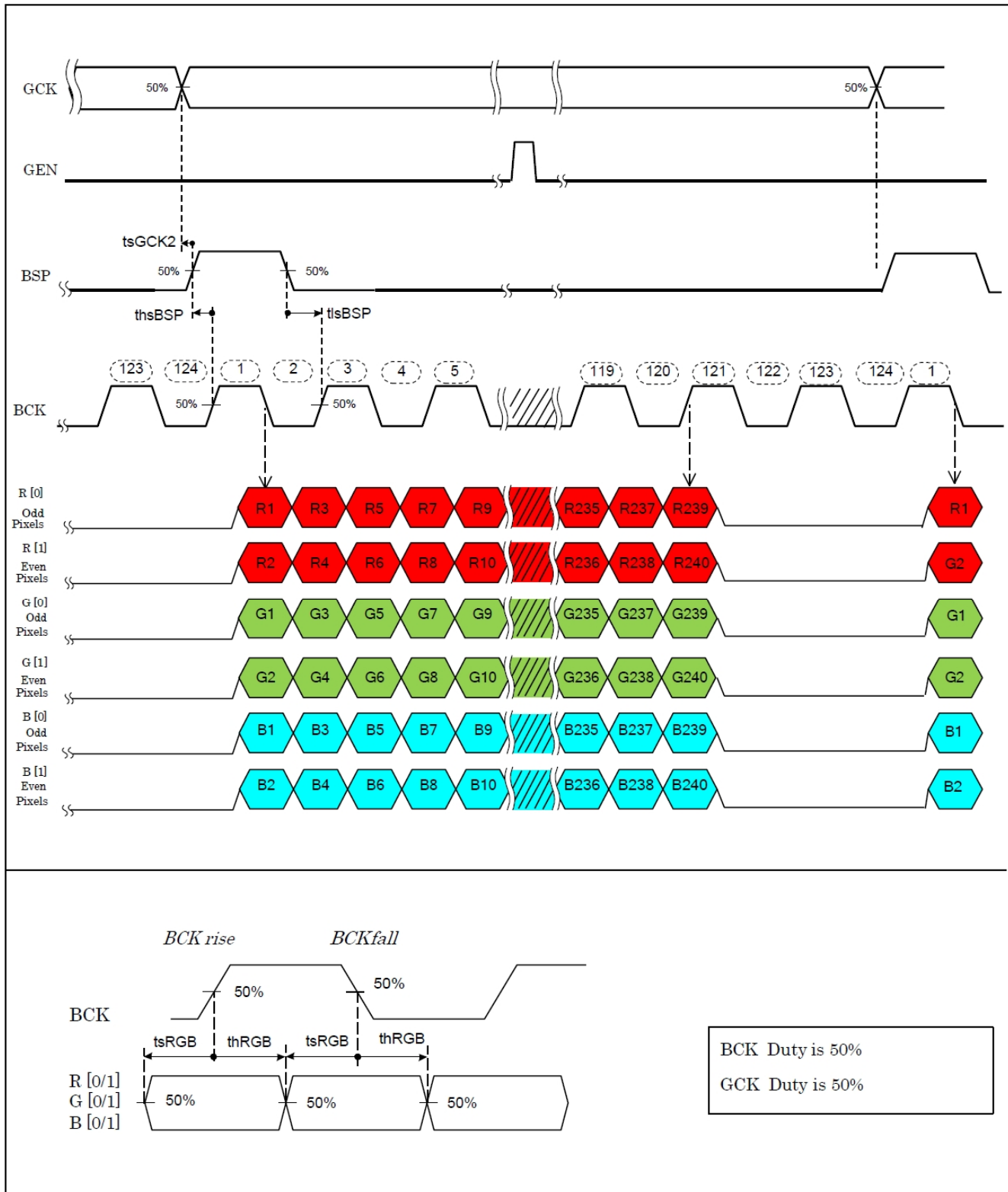

Figure : AC Timing 3

Input Signal and the transfer method of data.

Example : Updates Gate Line 1

- (1) First: Transfer MSB data of 1 line, Second: Transfer LSB data of 1 line
- (2) Repeat 1) from 1st line to 320th line, can update full screen.

Input Signal Timing Chart

Vertical Standard Timing.

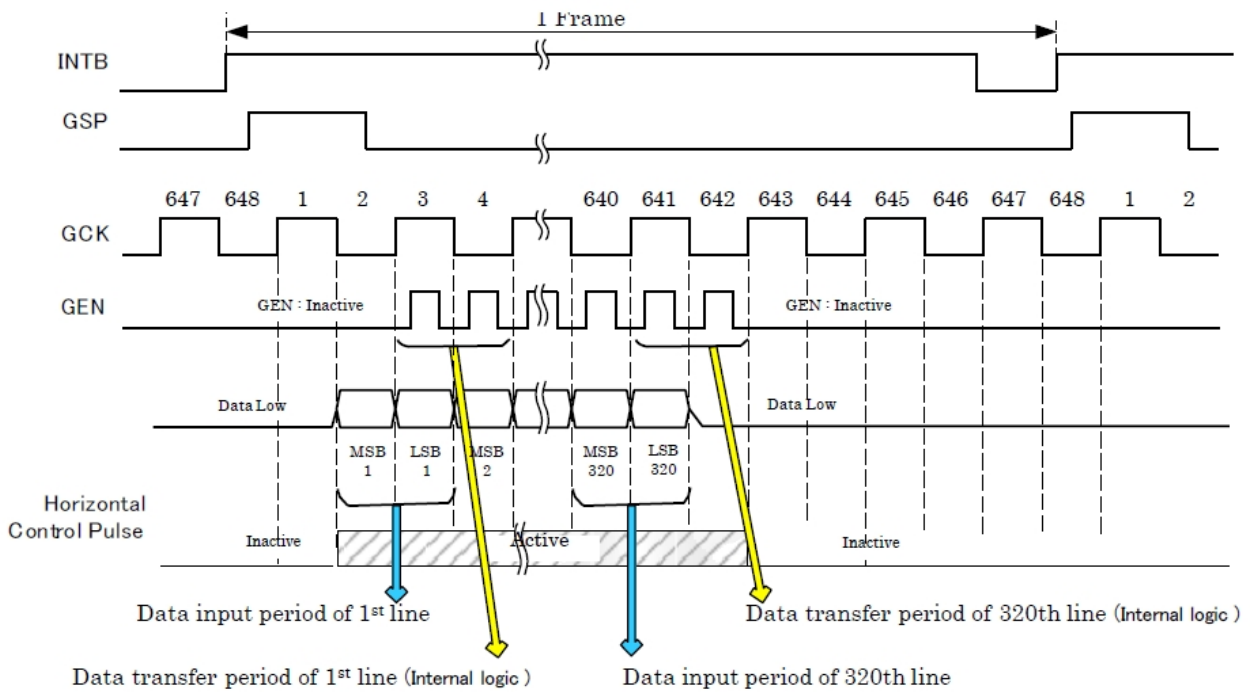

Data : R[0],R[1],G[0],G[1],B[0],B[1]
 Horizontal Control Pulse : BCK,BSP

Figure: Vertical Diagram

Horizontal Standard Timing

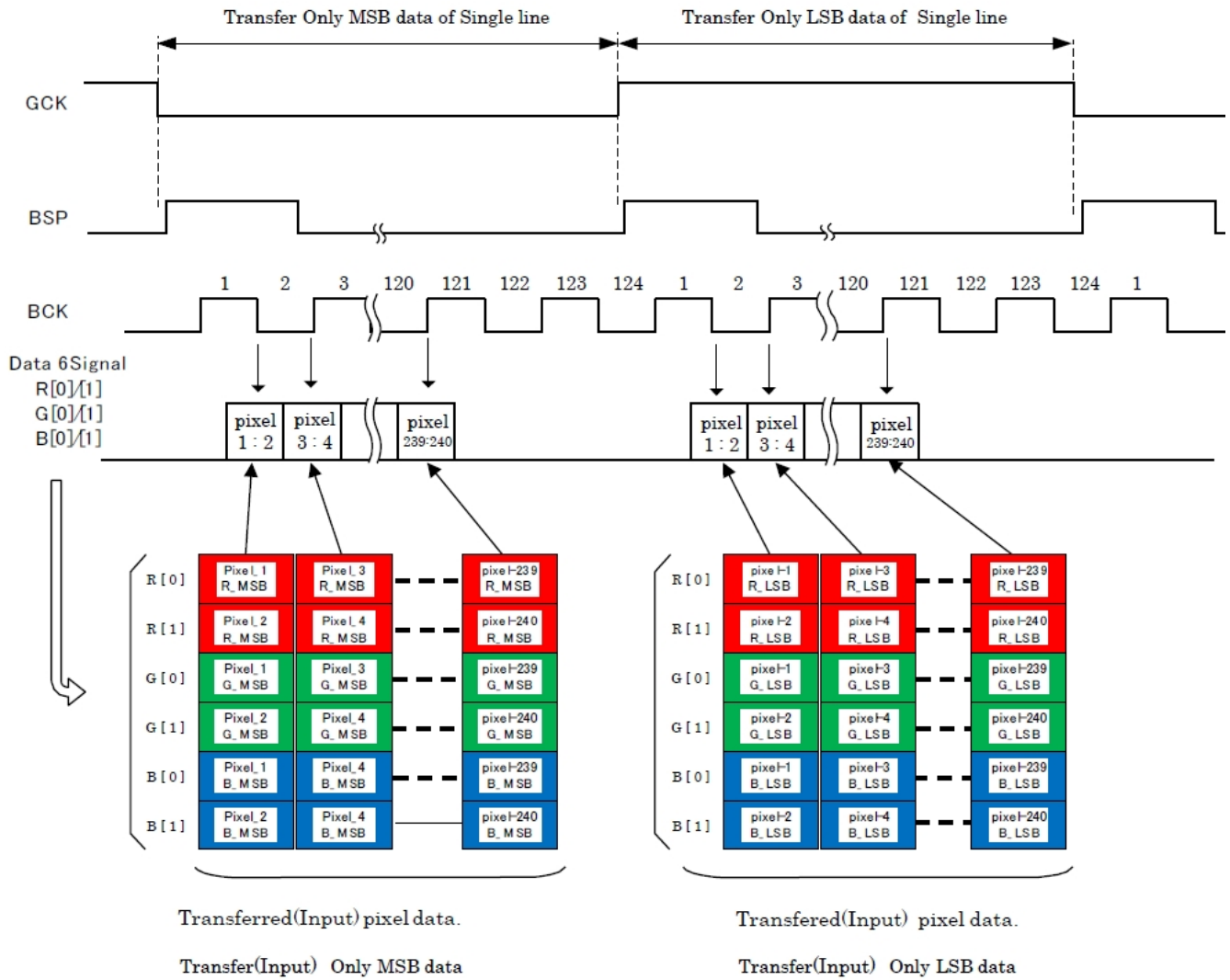

Figure: Horizontal Diagram

Partial Update mode (AC Timing & Diagram)

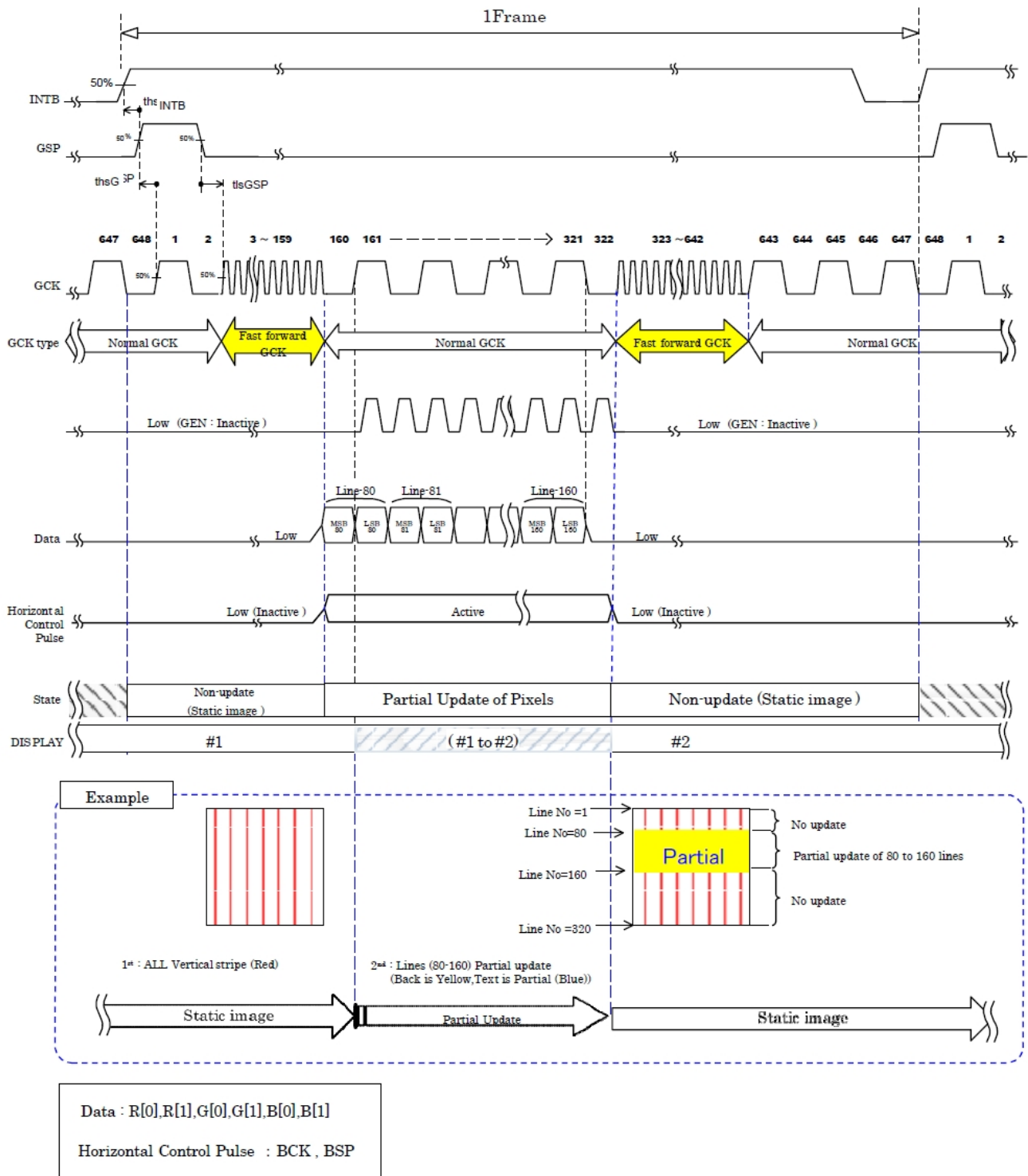

Figure: Partial Update

3.3 Power Supply Sequence

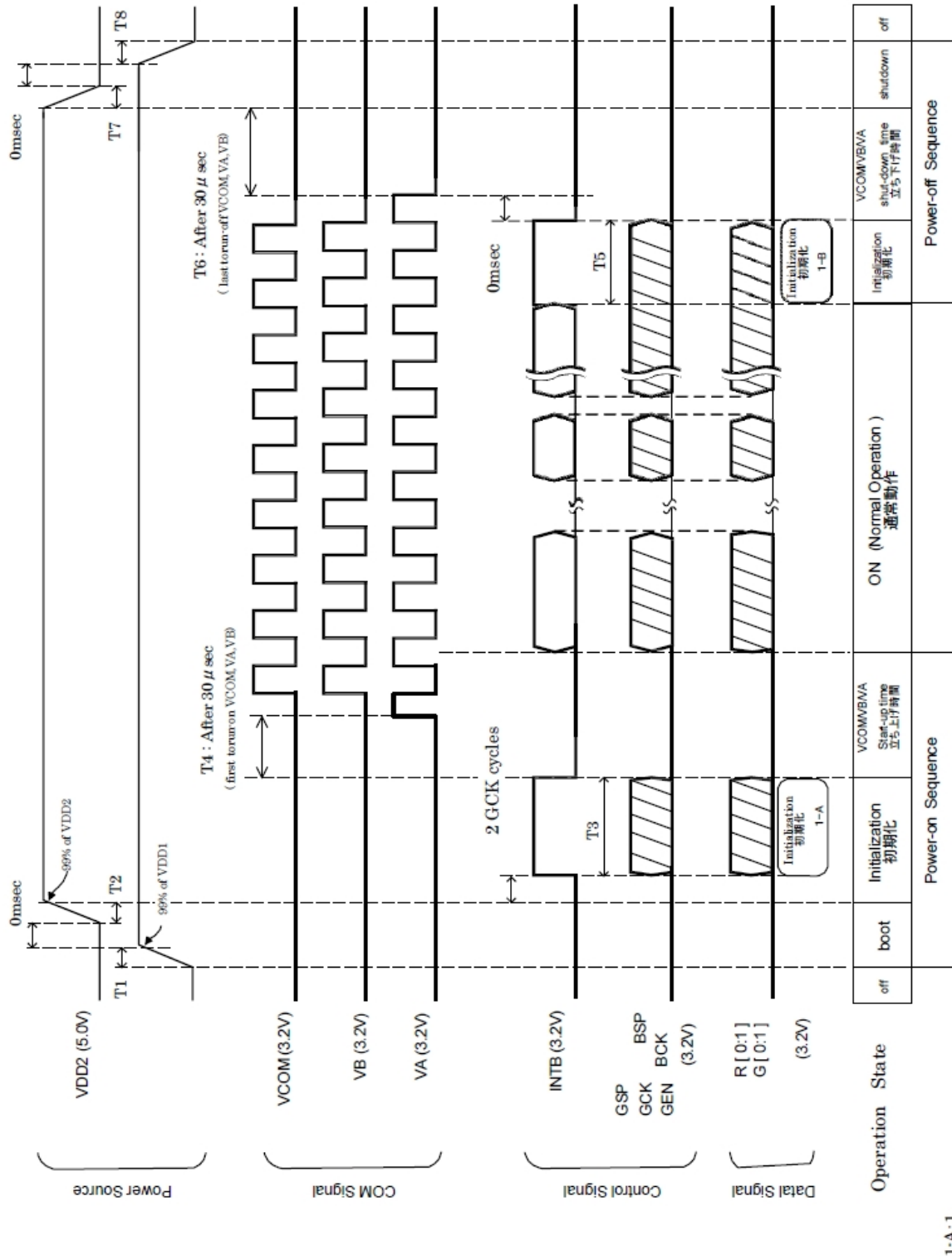

Figure: Power Supply Sequence

4. Optical Characteristics

4.1 Optical characteristic of the LCD

The following items are measured under stable conditions. The optical characteristics should be measured in a dark room or equivalent state with the methods.

Measuring equipment: BM-7A

Item	Symbol	Condition	Min	Type	Max	Unit	Note	
Reflectivity Ratio	R	--	6.5	8.7	--	%	--	
Transmissivity Ratio	T	--	--	(1.2)	--	%	--	
Response Time	$T_r + T_f$	$\theta = 0^\circ$	--	40	80	ms	--	
Contrast Ratio	CR	At optimized Viewing Angle	15	25	--	--	--	
NTSC	--	--	--	18	--	--	--	
Color Chromaticity (CIE 1931)	White	Wx	$\theta = 0^\circ$ Normal Viewing Angle	--	(0.318)	--	--	BM-7A
		Wy		--	(0.347)	--		
Viewing Angle	Hor.	θ_R	CR \geq 10	40	60	--	Degree	--
		θ_L		40	60	--		
	Ver.	θ_U		40	60	--		
		θ_D		40	60	--		

Test equipment setup

After stabilizing and leaving the panel alone shall be warmed up for the stable operation of LCM, the measurement should be executed. Measurement should be executed in a stable, windless, and dark room. Optical specifications are measured by Topcon BM-7(fast) with a viewing angle of 2° at a distance of 50cm and normal direction.

a. Definition of response time: T_r and T_f

The response time is defined as the following figure and shall be measured by switching the input signal for "black" and "white".

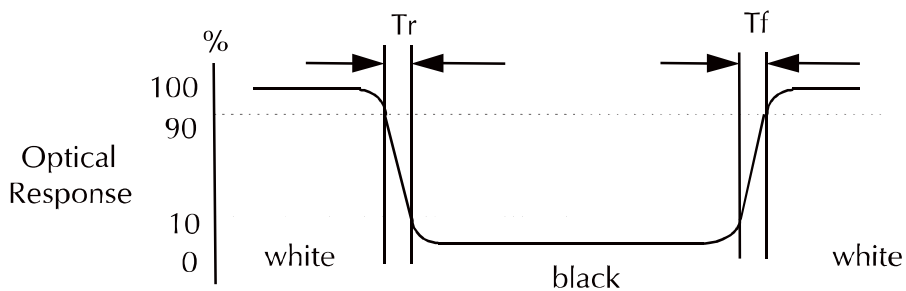

b. Definition of contrast ratio:

$$\text{Contrast Ratio (CR)} = \frac{\text{Brightness measured when LCD is at "white state"}}{\text{Brightness measured when LCD is at "black state"}}$$

c. Measured at the center area of the panel when all the input terminals of LCD panel are electrically opened.

d. View Angle

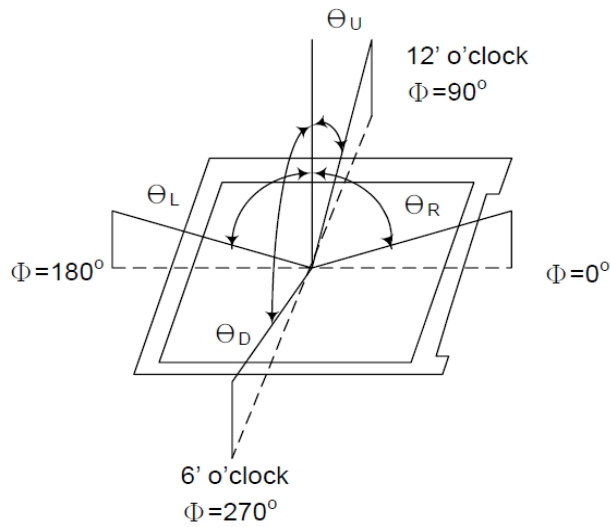

e. Definition of Luminance of White: Luminance of white at the center points

Light Source of Back-Light Unit	LED Type
---------------------------------	----------

f. Definition of White Uniformity

$$\text{White Uniformity} = \frac{\text{Min. luminance of white among 9-points}}{\text{Max. luminance of white among 9-points}} \times 100\%$$

g. The definition of Color Gamut -Color Chromaticity CIE 1931

Color coordinate of white & red, green, blue at center point.

Color Gamut : NTSC(%) = (RGB Triangle Area / NTSC Triangle Area) x 100

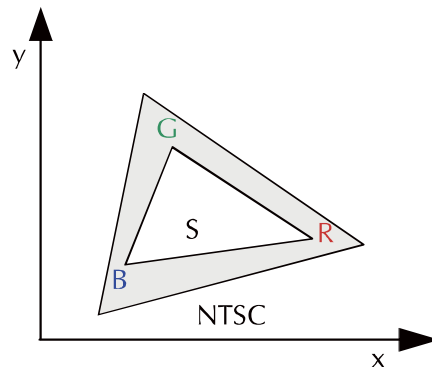

5. I/O Terminal

5.1 LCM Pin define (Connector: Molex 503566-2100 or equivalent)

Pin No	Symbol	I/O	Configuration	Function	NOTE
1	VDD2	Power	—	Power supply for the Vertical Driver	
2	(NC)	—	—	Open (No connection)	
3	GSP	Input	NoPull	Start signal for the Gate-Driver	
4	GCK	Input	NoPull	Clock for signal for the Gate-Driver	
5	GEN	Input	NoPull	Gate enable signal	
6	INTB	Input	NoPull	Initial signal for Binary/Gate-Driver	
7	VB	Input	—	Black signal voltage of LCD Inphase signal to VCOM / Duty=50% Square wave	Note 4-1 (Note 4-2)
8	VA	Input	—	White signal voltage of LCD Opposite phase signal to VCOM / Duty=50% Square wave	Note 4-1
9	VDD1	Power	—	Power supply for the Horizontal driver and the Pixels mem	
10	VSS	Power	—	GND	
11	BSP	Input	NoPull	Start signal for the Binary-Driver	
12	BCK	Input	NoPull	Clock for driving of Binary-Driver	
13	R [0]	Input	NoPull	Red signal for odd Pixels	
14	R [1]	Input	NoPull	Red signal for even Pixels	
15	G [0]	Input	NoPull	Green signal for odd Pixels	
16	G [1]	Input	NoPull	Green signal for even Pixels	
17	B [0]	Input	NoPull	Blue signal for odd Pixels	
18	B [1]	Input	NoPull	Blue signal for even Pixels	
19	(NC)	—	—	Open (No connection)	
20	VCOM	Input	—	Common terminal voltage for LCD / Duty=50% Square wave	Note 4-1
21	(NC)	—	—	Open (No connection)	

NoPull :

Neither Pulled up nor Pulled down.

Note 4-1:

Because of direct connecting to internal common electrode,
Please don't be static electricity/ripple/etc applied.

VB is the same signal as VCOM and VA is the inverse signal of VCOM and VB

Input Signal Level

Pin No	Symbol	I/O	Signal (type)	Voltage	Boot	Initial	(Update mode)	(Hold mode)
1	VDD2	Power	DC Power	5.0V	5.0V	5.0V	5.0V	5.0V
3	GSP	Input	Pulse Signal	0 / 3.2	0V	0V	Hi / Lo	0V
4	GCK	Input	CLK	0 / 3.2	0V	0V	CLK	0V
5	GEN	Input	Pulse Signal / Hi or Lo	0 / 3.2	0V	0V	Hi / Lo	0V
6	INTB	Input	Pulse Signal	0 / 3.2	0V	0V	Hi / Lo	0V
7	VB	Input	Square pulse	0 / 3.2	0V	0V	0 / 3.2	0 / 3.2
8	VA	Input	Square pulse	0 / 3.2	0V	0V	0 / 3.2	0 / 3.2
9	VDD1	Power	DC Power	3.2V	3.2V	3.2V	3.2V	3.2V
10	VSS	Power	GND	0V	0V	0V	0V	0V
11	BSP	Input	Pulse Signal	0 / 3.2	0V	0V	Hi / Lo	0V
12	BCK	Input	CLK	0 / 3.2	0V	0V	CLK	0V
13	R [0]	Input	Logic Signal	0 / 3.2	0V	0V	Hi / Lo	0V
14	R [1]	Input	Logic Signal	0 / 3.2	0V	0V	Hi / Lo	0V
15	G [0]	Input	Logic Signal	0 / 3.2	0V	0V	Hi / Lo	0V
16	G [1]	Input	Logic Signal	0 / 3.2	0V	0V	Hi / Lo	0V
17	B [0]	Input	Logic Signal	0 / 3.2	0V	0V	Hi / Lo	0V
18	B [1]	Input	Logic Signal	0 / 3.2	0V	0V	Hi / Lo	0V
20	VCOM	Input	Square pulse	0 / 3.2	0V	0V	0 / 3.2	0 / 3.2

※ Above each Voltage value is typical.

※Boot : When just input Power

※Initial : Between PowerON and Input Signal.

※Data Update mode : Updates data in pixel memory.

※Hold mode : Maintains memory internal data and maintain current display

5.2 Block Diagram

P*: Pixels position
L*: Gate line

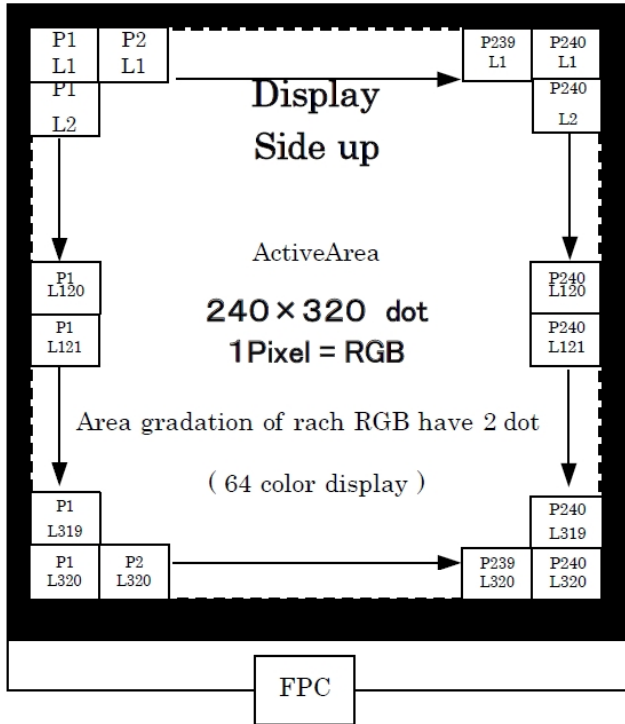

Pin	Signal Data
R [0]	Red signal for odd Pixels
R [1]	Red signal for even Pixels
G [0]	Green signal for odd Pixels
G [1]	Green signal for even Pixels
B [0]	Blue signal for odd Pixels
B [1]	Blue signal for even Pixels

Bit-data	Relationship between bit data and pixel
MSB	MSB Pixel Block occupies 2/3 the subpixels of the each pixels.
LSB	LSB Pixel Block occupies 1/3 the subpixels of the each pixels.

About Pixel data of 1 line and the area ratio of 1 pixel.

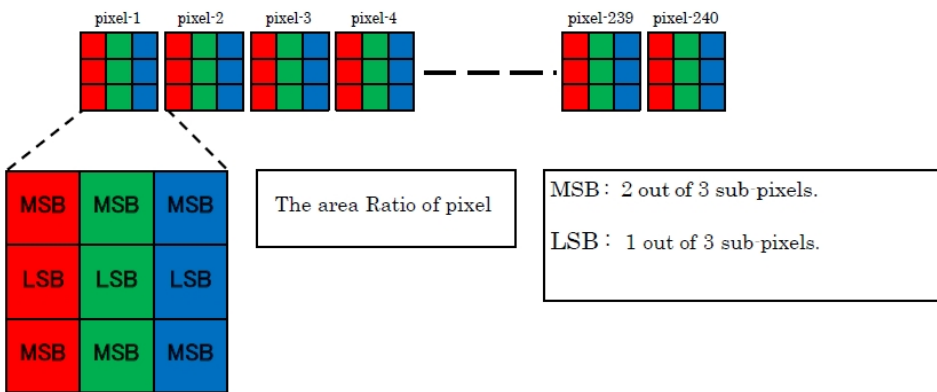

6. Reliability Condition

No change on display and in operation under the following test condition.

Condition: Unless otherwise specified, tests will be conducted under the following condition.

Temperature: 20°C ± 5°C.

Humidity: 65%±5%RH.

Tests will be not conducted under functioning state.

No.	Parameter	Condition	Notes
1	High Temperature Operating	70°C ± 2°C, 240hrs (Operation state).	--
2	Low Temperature Operating	-20°C ± 2°C, 240hrs (Operation state).	1
3	High Temperature Storage	80°C ± 2°C, 240hrs.	2
4	Low Temperature Storage	-30°C ± 2°C, 240hrs.	1,2
5	High Temperature and High Humidity Operation Test	40°C ± 2°C, 95%, 240hrs.	1,2

Notes:

1. No dew condensation to be observed.
2. The function test shall be conducted after 4 hours storage at the normal temperature and humidity after removed from the test chamber.

7. Dimensional Outlines

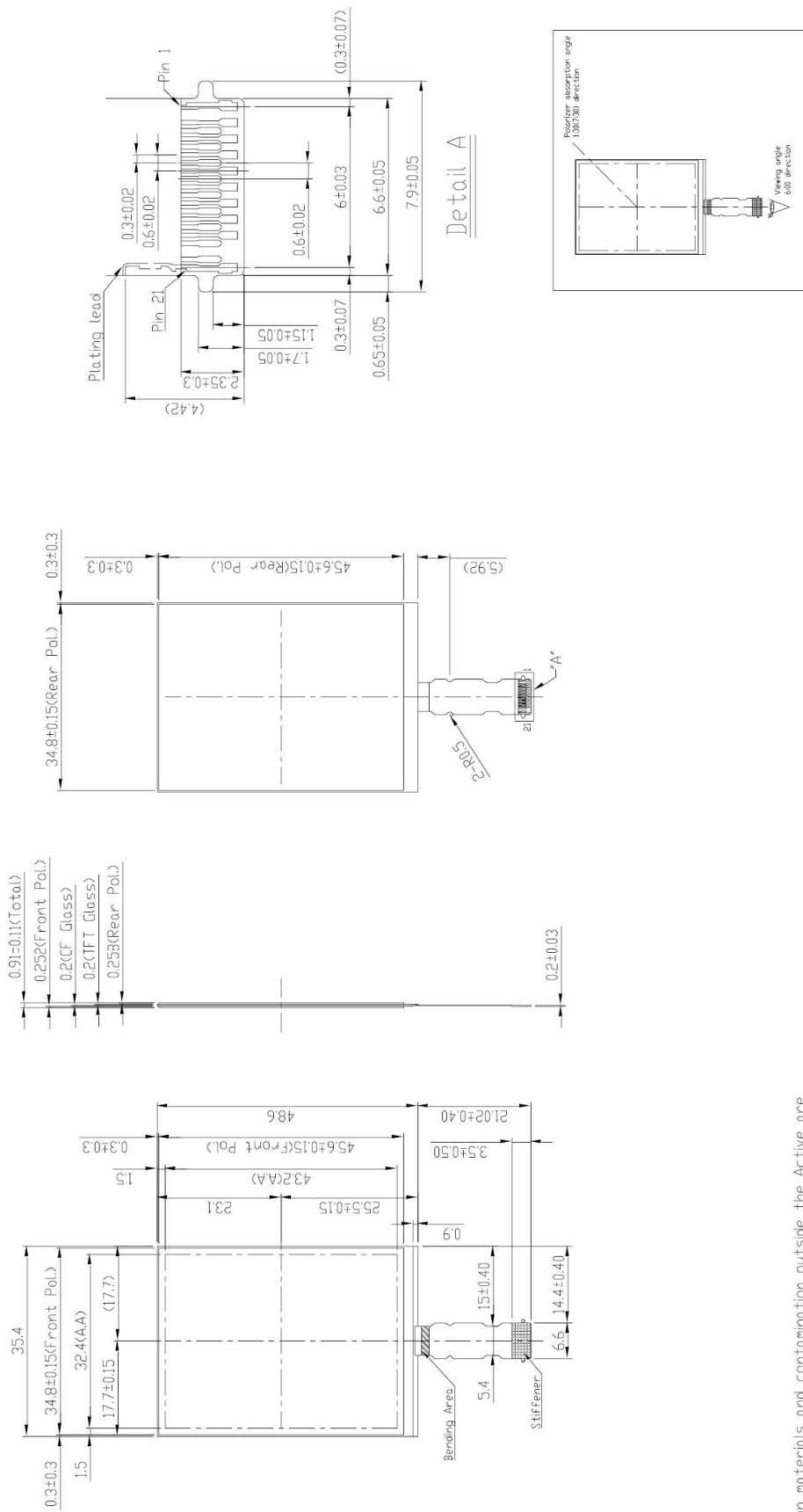

- Notes :
1. Any foreign materials and contamination outside the Active are to be treated as "ND-Count" at our inspections.
 2. Guarantee of appearance=LCD Active area.
 3. General tolerance is +/-0.2.
 4. Minimum inside bend radius:0.45mm.
 5. Please design carefully to hide the polarizer and other frame areas, which are outside of the guaranteed area.
 6. As the light from backlight may leak from the gap at outside of Active area, which are outside of active are, please pay attentions to such leakage when designing the set.
 7. There are metal patterns on the outer edge of FPC.
 8. The tolerances of the module width do not include warp of the glass.