

**Display Elektronik GmbH**

# DATA SHEET

**MIP Display**

**DE MIP176176A-W-PW**

(1,28“ MIP Display, mono)

**Product Specification**

**Ver.: 2**

**04.10.2024**



## Contents

<b>1</b>	<b>General Description and Features</b> .....	<b>4</b>
1.1	Features	4
1.2	LCD Module	4
<b>2</b>	<b>Mechanical Information</b> .....	<b>4</b>
<b>3</b>	<b>Electrical Specifications</b> .....	<b>5</b>
3.1	Absolute Max. Ratings	5
3.2	Electrical Absolute Rating	5
<b>4</b>	<b>Electrical Characteristics</b> .....	<b>6</b>
4.1	TFT-LCD Module	6
<b>5</b>	<b>Block Diagram</b> .....	<b>7</b>
<b>6</b>	<b>Input Terminal Pin Assignment</b> .....	<b>8</b>
6.1	Pin Assignment	8
<b>7</b>	<b>Optical Characteristics</b> .....	<b>9</b>
<b>8</b>	<b>Gate line address setting</b> .....	<b>11</b>
8.1	AC Characteristics	12
8.2	Input signal characteristics	14
<b>9</b>	<b>Test</b> .....	<b>18</b>
<b>10</b>	<b>Dimensional outlines</b> .....	<b>19</b>
<b>11</b>	<b>Incoming Inspection Standards</b> .....	<b>20</b>

**1 General Description and Features**

The specifications are applied to LTPS (Memory in Pixel type) display DE MIP176176A-W-PW

**1.1 Features**

- Backlight with 2 LEDs
- Reflective type
- ROHS Compliance

**1.2 LCD Module**

Item	Specification	Unit
Screen Size	1.28 Inches	Diagonal
Display Resolution	176 x 176	Dot
Pixel Pitch	0.1308 x 0.1308	mm
Active Area	23.208 x 23.208	mm
Outline Dimension	26.62 x 29.72 x 1.45 mm	mm
Display Mode	Normally White (Reflective Type)	--
Pixel Arrangement	Square	--
Surface Treatment	Anti-Glare (AG)	--

**2 Mechanical Information**

Item		Min.	Typ.	Max.	Unit	Note
Module Size	Horizontal (H)	--	26.62	--	mm	--
	Vertical (V)	--	29.72	--	mm	(1)
	Thickness (T)	--	1.45	--	mm	(1)
Weight		--	2	--	g	--

Note (1) Not include FPC.

Refer to the Dimensional Outlines for further information.

**3 Electrical Specifications**

**3.1 Absolute Max. Ratings**

**3.1.1 Absolute Ratings of Environment**

If the operating condition exceeds the following absolute maximum ratings, the TFT LCD module may be damaged permanently.

(Ta=25±2°C, Vss=GND=0)

Item	Symbol	Min.	Max.	Unit	Note
Storage Temperature	T <sub>STG</sub>	-30	80	°C	(1)
Operating Temperature	T <sub>OPR</sub>	-20	70	°C	(1,2)

Note (1) Ta≤40°C: 85%RH Max.

Ta > 40°C: Absolute humidity needs to be equal or less than the numeric value at the condition of Ta=40°C, 85%RH.

Note (2) Only operation is guaranteed at operating temperature. Contrast, response time, another display quality are evaluated at +25°C.

**3.2 Electrical Absolute Rating**

**3.2.1 TFT-LCD Module**

(Ta=25±2°C, Vss=GND=0)

Item	Symbol	Value		Unit	Condition
		Min.	Max.		
Power Supply Voltage	V <sub>DD</sub>	-0.3	3.6	V	

**3.2.2 Back-Light Unit**

(Ta=25±2°C)

Item	Symbol	Min.	Max.	Unit	Note
Current of One LED	I <sub>LED</sub>	--	20	mA	(1)

Note (1) Permanent damage to the device may occur if maximum values are exceeded or reverse voltage is loaded. Functional operation should be restricted to the conditions described under normal operating conditions.

**4 Electrical Characteristics**

**4.1 TFT-LCD Module**

(Ta=25±2°C, VDD =3.3V)

Item	Symbol	Value			Unit	Condition
		Min.	Typ.	Max.		
Power Supply Voltage	V <sub>DD</sub>	2.7	3.0	3.3	V	
Input Voltage for logic	H Level	V <sub>DD-0.1</sub>	V <sub>DD</sub>	V <sub>DD</sub>	V	
	L Level	V <sub>SS</sub>	V <sub>SS</sub>	V <sub>SS+0.1</sub>	V	
Hold Mode (No Display Date Update) Display Pattern:	BLACK display	--	25	85	μW	(1)
Date Update Mode with Display Update 1Hz (1fram/sec) Display Pattern:	Vertical stripe display	--	30	90	μW	(2)

Note: (1) After writed Black data、 set to 「SCLK=Lo, SCS=Lo, SI=Lo」

(2) Except in the time of writing, it is set to SCS=Lo)

Common condition VDD=3.0V、 VDDA=3.0V、 fCLK=1.0MHz、 EXTMODE=VDD、 EXTCOMIN=60Hz

The back-light system is an edge-lighting type with white LED (Light Emitting Diode)s.

(Ta=25±2°C)

Item	Symbol	Value			Unit	Condition
		Min.	Typ.	Max.		
LED Voltage	V <sub>L</sub>	-	2.6	2.8	V	-
LED Current	I <sub>f</sub>	-	6	7.5	mA	-
Power Consumption	P <sub>BL</sub>	-	16.2	20.25	mW	(2)
LED Lifetime (25°C)	-	30000	-	-	hr	(3)

Note :(1) 1LEDs serial 1 parallel type 2.

(2) Where If = 6mA, VL = 2.6V, PBL = VL × If

(3)The environmental conducted under ambient air flow, at Ta=25°C±2°C, 60%RH±5%

5 Block Diagram

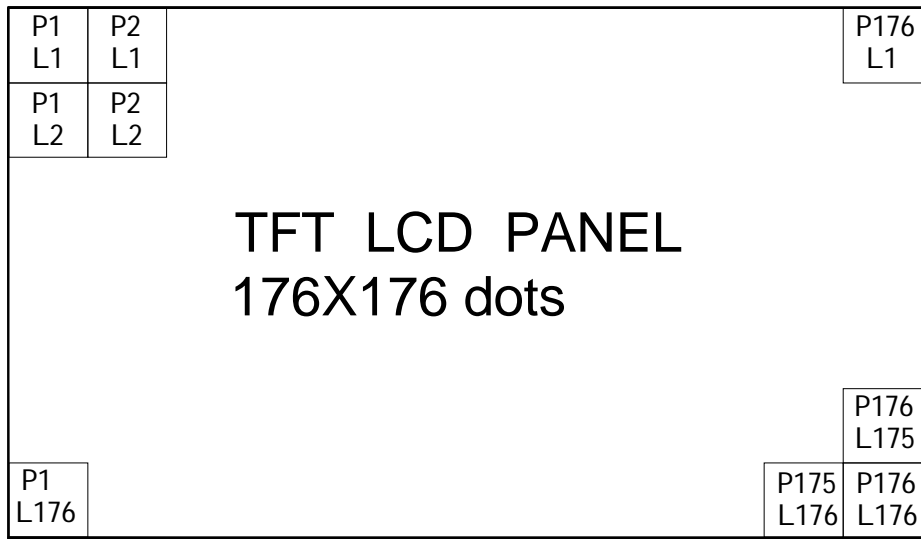

SCLK,SI,SCS,EXTCOMIN,  
DISP,VDDA,VDD,EXTMODE,  
VSS,VSSA

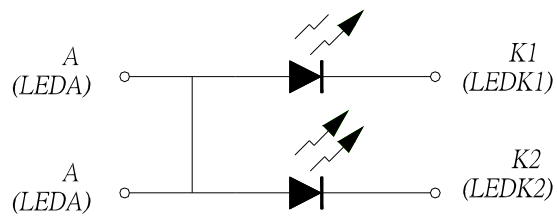
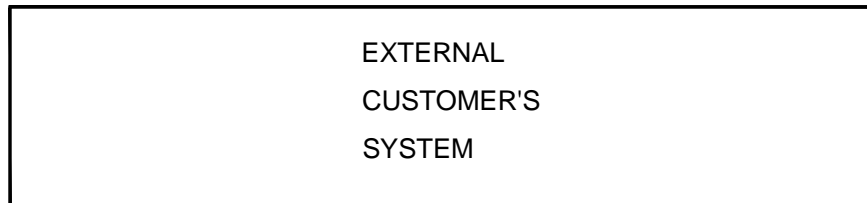

**6 Input Terminal Pin Assignment****6.1 Pin Assignment**

Pin No.	Symbol	I/O	Function	Remark
1	SCLK	P	Serial Clock Signal	-
2	SI	P	Serial Data Input Signal	-
3	SCS	P	Chip Select Signal	-
4	EXTCOMIN	P	COM Inversion Polarity Input	Note1
5	DISP	I	Display ON/OFF Switching Signal	Note2
6	VDDA	I	Power Supply for Analog	-
7	VDD	I	Power Supply for Logic	-
8	EXTMODE	I	COM Inversion Mode Select Terminal	Note1
9	VSS	I	Logic Ground	-
10	VSSA	I	Analog Ground	-

**Note1:**

When EXTMODE is “Hi”, EXTCOMIN signal is enable.

When EXTMODE is “Lo”, serial input flag is enable.

“Hi”mode ; connect the EXTMODE to VDD,

“Lo” mode ; connect the EXTMODE and EXTCOMIN to VSS.

**Note2:**

The display ON/OFF signal is only for display.

Data in the memory will be saved at the time of ON/OFF.

When it's “Hi”, data in the memory will display, when it's “Lo”, white color will display and data in the memory will be saved.

7 Optical Characteristics

The following items are measured under stable conditions. The optical characteristics should be measured in a dark room

Measuring equipment: BM-7A

(Ta=25±2°C , VDD =3.3V, If=40mA)

Item	Symbol	Condition	Min	Type	Max	Unit	Note	
Brightness	--	--	--	10	--	cd/m <sup>2</sup>	--	
Response Time	T <sub>R</sub>	θ=0°	--	10	(20)	ms	--	
	T <sub>F</sub>		--	20	(40)	ms		
Contrast Ratio	CR	At optimized viewing angle	13	18	--	--	--	
Luminance Uniformity	ΔL		70	80		%		
Color Chromaticity	White	θ=0° Normal Viewing Angle	W <sub>x</sub>	0.27	0.32	0.37	--	--
			W <sub>y</sub>	0.29	0.34	0.39	--	
Viewing Angle (6H)	Hor.	CR≥10	θ <sub>R</sub>	40	60	--	Degree	--
			θ <sub>L</sub>	40	60	--		
	Ver.		θ <sub>U</sub>	40	60	--		
			θ <sub>D</sub>	40	60	--		

a. Test equipment setup

After stabilizing and leaving the panel alone shall be warmed up for the stable operation of LCM, the measurement should be executed. Measurement should be executed in a stable, windless, and dark room. Optical specifications are measured by Topcon BM-5A/BM-7(fast) with a viewing angle of 2° at a distance of 50cm and normal direction.

b. Definition of response time: Tr and Tf

The response time is defined as the following figure and shall be measured by switching the input signal for "black" and "white".

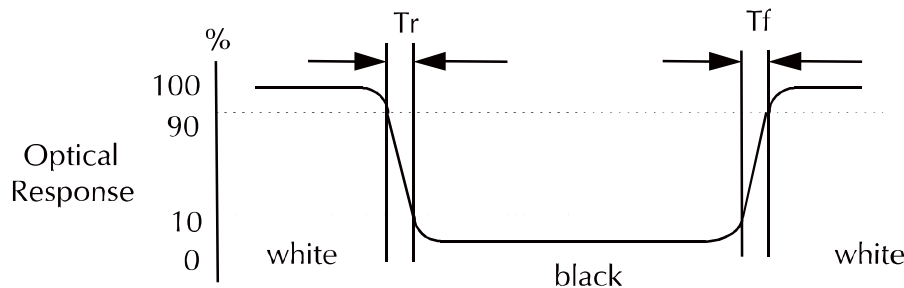

c. Definition of contrast ratio:

Brightness measured when LCD is at "white state"

$$\text{Contrast Ratio (CR)} = \frac{\text{Brightness measured when LCD is at "white state"}}{\text{Brightness measured when LCD is at "black state"}}$$

Brightness measured when LCD is at "black state"

- d. Measured at the center area of the panel when all the input terminals of LCD panel are electrically opened.
- e. View Angle

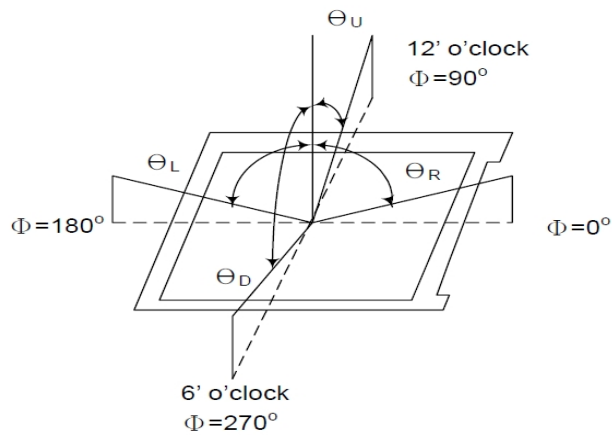

- f. Definition of Luminance of White: Luminance of white at the center points

Light Source of Back-Light Unit	LED Type
---------------------------------	----------

- g. Definition of White Uniformity

$$\text{White Uniformity} = \frac{\text{Min. luminance of white among 9-points}}{\text{Max. luminance of white among 9-points}} \times 100\%$$

8 Gate line address setting

GL	AG0	AG1	AG2	AG3	AG4	AG5	AG6	AG7	GL	AG0	AG1	AG2	AG3	AG4	AG5	AG6	AG7	GL	AG0	AG1	AG2	AG3	AG4	AG5	AG6	AG7
1	1	0	0	0	0	0	0	0	61	1	0	1	1	1	1	0	0	121	1	0	0	1	1	1	1	0
2	0	1	0	0	0	0	0	0	62	0	1	1	1	1	1	0	0	122	0	1	0	1	1	1	1	0
3	1	1	0	0	0	0	0	0	63	1	1	1	1	1	1	0	0	123	1	1	0	1	1	1	1	0
4	0	0	1	0	0	0	0	0	64	0	0	0	0	0	0	1	0	124	0	0	1	1	1	1	1	0
5	1	0	1	0	0	0	0	0	65	1	0	0	0	0	0	1	0	125	1	0	1	1	1	1	1	0
6	0	1	1	0	0	0	0	0	66	0	1	0	0	0	0	1	0	126	0	1	1	1	1	1	1	0
7	1	1	1	0	0	0	0	0	67	1	1	0	0	0	0	1	0	127	1	1	1	1	1	1	1	0
8	0	0	0	1	0	0	0	0	68	0	0	1	0	0	0	1	0	128	0	0	0	0	0	0	0	1
9	1	0	0	1	0	0	0	0	69	1	0	1	0	0	0	1	0	129	1	0	0	0	0	0	0	1
10	0	1	0	1	0	0	0	0	70	0	1	1	0	0	0	1	0	130	0	1	0	0	0	0	0	1
11	1	1	0	1	0	0	0	0	71	1	1	1	0	0	0	1	0	131	1	1	0	0	0	0	0	1
12	0	0	1	1	0	0	0	0	72	0	0	0	1	0	0	1	0	132	0	0	1	0	0	0	0	1
13	1	0	1	1	0	0	0	0	73	1	0	0	1	0	0	1	0	133	1	0	1	0	0	0	0	1
14	0	1	1	1	0	0	0	0	74	0	1	0	1	0	0	1	0	134	0	1	1	0	0	0	0	1
15	1	1	1	1	0	0	0	0	75	1	1	0	1	0	0	1	0	135	1	1	1	0	0	0	0	1
16	0	0	0	0	1	0	0	0	76	0	0	1	1	0	0	1	0	136	0	0	0	1	0	0	0	1
17	1	0	0	0	1	0	0	0	77	1	0	1	1	0	0	1	0	137	1	0	0	1	0	0	0	1
18	0	1	0	0	1	0	0	0	78	0	1	1	1	0	0	1	0	138	0	1	0	1	0	0	0	1
19	1	1	0	0	1	0	0	0	79	1	1	1	1	0	0	1	0	139	1	1	0	1	0	0	0	1
20	0	0	1	0	1	0	0	0	80	0	0	0	0	1	0	1	0	140	0	0	1	1	0	0	0	1
21	1	0	1	0	1	0	0	0	81	1	0	0	0	1	0	1	0	141	1	0	1	1	0	0	0	1
22	0	1	1	0	1	0	0	0	82	0	1	0	0	1	0	1	0	142	0	1	1	1	0	0	0	1
23	1	1	1	0	1	0	0	0	83	1	1	0	0	1	0	1	0	143	1	1	1	1	0	0	0	1
24	0	0	0	1	1	0	0	0	84	0	0	1	0	1	0	1	0	144	0	0	0	0	1	0	0	1
25	1	0	0	1	1	0	0	0	85	1	0	1	0	1	0	1	0	145	1	0	0	0	1	0	0	1
26	0	1	0	1	1	0	0	0	86	0	1	1	0	1	0	1	0	146	0	1	0	0	1	0	0	1
27	1	1	0	1	1	0	0	0	87	1	1	1	0	1	0	1	0	147	1	1	0	0	1	0	0	1
28	0	0	1	1	1	0	0	0	88	0	0	0	1	1	0	1	0	148	0	0	1	0	1	0	0	1
29	1	0	1	1	1	0	0	0	89	1	0	0	1	1	0	1	0	149	1	0	1	0	1	0	0	1
30	0	1	1	1	1	0	0	0	90	0	1	0	1	1	0	1	0	150	0	1	1	0	1	0	0	1
31	1	1	1	1	1	0	0	0	91	1	1	0	1	1	0	1	0	151	1	1	1	0	1	0	0	1
32	0	0	0	0	0	1	0	0	92	0	0	1	1	1	0	1	0	152	0	0	0	1	1	0	0	1
33	1	0	0	0	0	1	0	0	93	1	0	1	1	1	0	1	0	153	1	0	0	1	1	0	0	1
34	0	1	0	0	0	1	0	0	94	0	1	1	1	1	0	1	0	154	0	1	0	1	1	0	0	1
35	1	1	0	0	0	1	0	0	95	1	1	1	1	1	0	1	0	155	1	1	0	1	1	0	0	1
36	0	0	1	0	0	1	0	0	96	0	0	0	0	0	1	1	0	156	0	0	1	1	1	0	0	1
37	1	0	1	0	0	1	0	0	97	1	0	0	0	0	1	1	0	157	1	0	1	1	1	0	0	1
38	0	1	1	0	0	1	0	0	98	0	1	0	0	0	1	1	0	158	0	1	1	1	1	0	0	1
39	1	1	1	0	0	1	0	0	99	1	1	0	0	0	1	1	0	159	1	1	1	1	1	0	0	1
40	0	0	0	1	0	1	0	0	100	0	0	1	0	0	1	1	0	160	0	0	0	0	0	1	0	1
41	1	0	0	1	0	1	0	0	101	1	0	1	0	0	1	1	0	161	1	0	0	0	0	1	0	1
42	0	1	0	1	0	1	0	0	102	0	1	1	0	0	1	1	0	162	0	1	0	0	0	1	0	1
43	1	1	0	1	0	1	0	0	103	1	1	1	0	0	1	1	0	163	1	1	0	0	0	1	0	1
44	0	0	1	1	0	1	0	0	104	0	0	0	1	0	1	1	0	164	0	0	1	0	0	1	0	1
45	1	0	1	1	0	1	0	0	105	1	0	0	1	0	1	1	0	165	1	0	1	0	0	1	0	1
46	0	1	1	1	0	1	0	0	106	0	1	0	1	0	1	1	0	166	0	1	1	0	0	1	0	1
47	1	1	1	1	0	1	0	0	107	1	1	0	1	0	1	1	0	167	1	1	1	0	0	1	0	1
48	0	0	0	0	1	1	0	0	108	0	0	1	1	0	1	1	0	168	0	0	0	1	0	1	0	1
49	1	0	0	0	1	1	0	0	109	1	0	1	1	0	1	1	0	169	1	0	0	1	0	1	0	1
50	0	1	0	0	1	1	0	0	110	0	1	1	1	0	1	1	0	170	0	1	0	1	0	1	0	1
51	1	1	0	0	1	1	0	0	111	1	1	1	1	0	1	1	0	171	1	1	0	1	0	1	0	1
52	0	0	1	0	1	1	0	0	112	0	0	0	0	1	1	1	0	172	0	0	1	1	0	1	0	1
53	1	0	1	0	1	1	0	0	113	1	0	0	0	1	1	1	0	173	1	0	1	1	0	1	0	1
54	0	1	1	0	1	1	0	0	114	0	1	0	0	1	1	1	0	174	0	1	1	1	0	1	0	1
55	1	1	1	0	1	1	0	0	115	1	1	0	0	1	1	1	0	175	1	1	1	1	0	1	0	1
56	0	0	0	1	1	1	0	0	116	0	0	1	0	1	1	1	0	176	0	0	0	0	1	1	0	1
57	1	0	0	1	1	1	0	0	117	1	0	1	0	1	1	1	0									
58	0	1	0	1	1	1	0	0	118	0	1	1	0	1	1	1	0									
59	1	1	0	1	1	1	0	0	119	1	1	1	0	1	1	1	0									
60	0	0	1	1	1	1	0	0	120	0	0	0	1	1	1	1	0									

GL: Gate address line

8.1 AC Characteristics

Power supply sequence

Power on

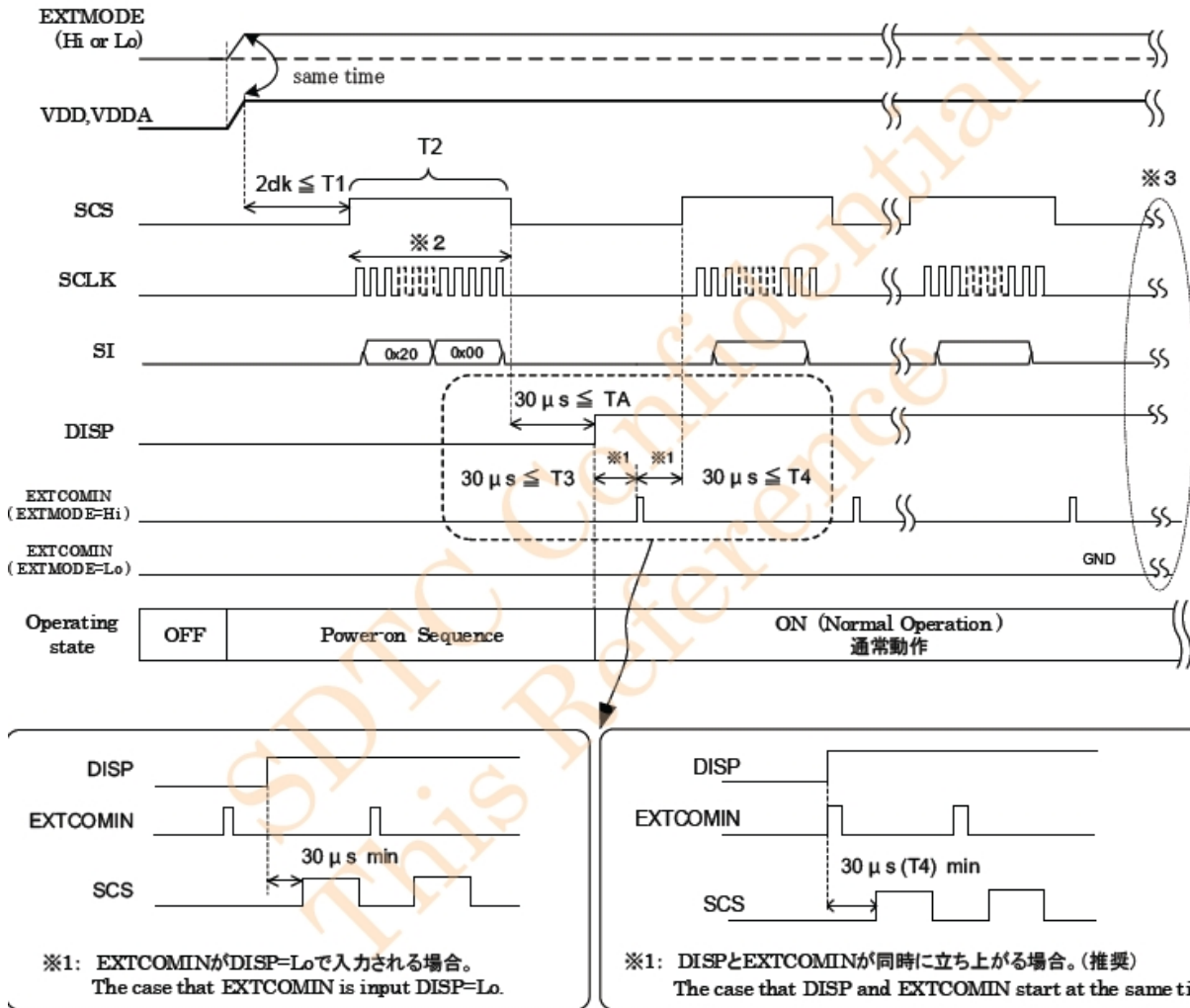

Power off

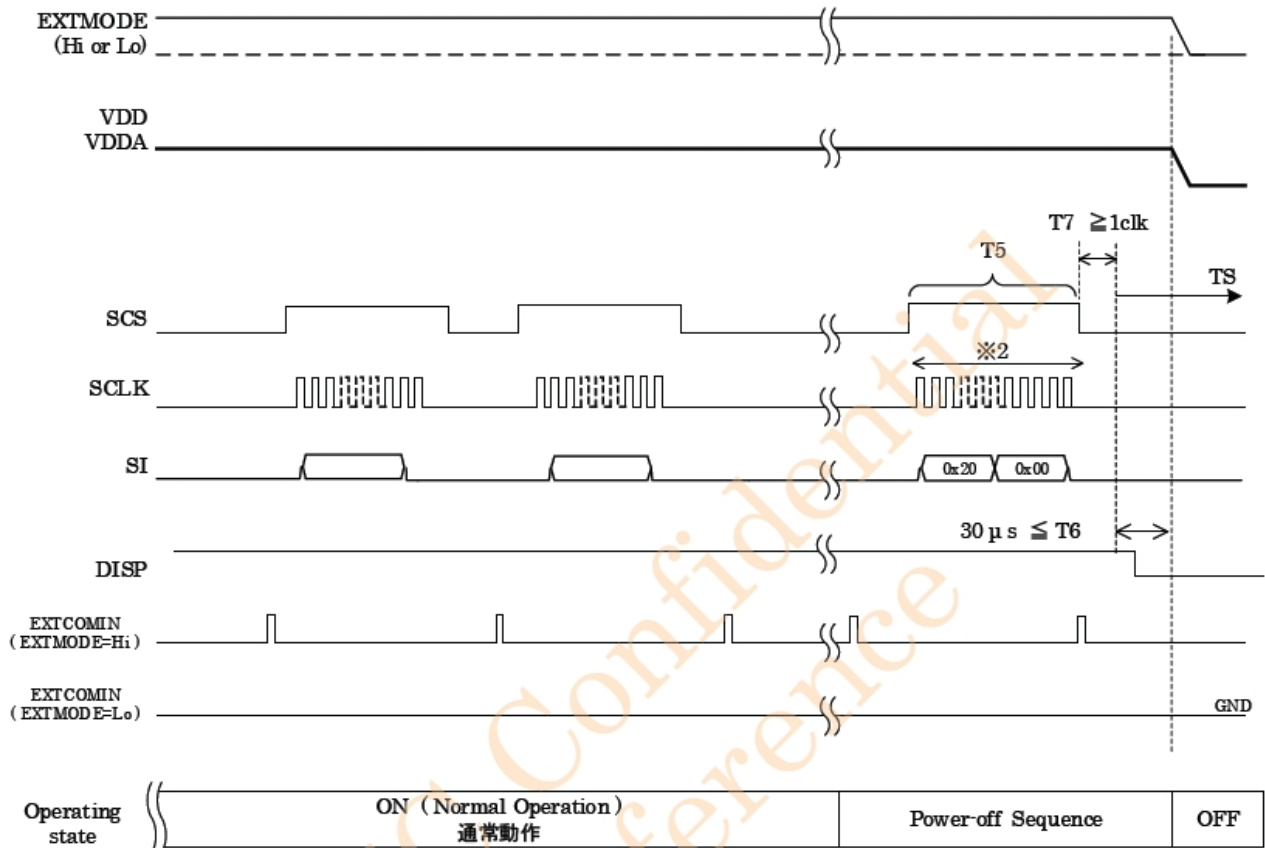

TS : Off control

全ての制御信号を“Lo”にした後、T6の時間を経過後に電源をOFFしてください。

Please turn off a power supply after making all the control signals into “Low Level”, and passing the time of T6.

8.2 Input signal characteristics

Input signal timing parameters

VDDA=+3.0V, VDD=+3.0V GND=0V, Ta=25°C

Item	Symbol	Min	Typ	Max	Unit	Remark
COM反転 COM Inversion	fV	57	60	90	Hz	When EXTMODE=Lo Figure 6-3-1, Figure 6-6-5 【Note 6-3-1】,【Note 6-3-5】
COM周波数 COM frequency	fCOM	28.5	—	45	Hz	【Note 6-3-5】
フレーム周波数 Frame frequency	fSCS	28.5	—	32.5	Hz	When EXTMODE=Lo 【Note 6-3-2】 【Note 6-3-4】,【Note 6-3-5】
		—	—	32.5	Hz	When EXTMODE=Hi 【Note 6-3-3】 【Note 6-3-4】,【Note 6-3-5】

【Note 6-3-1】 COM制御をシリアルデータにて行う場合。  
COM driving by the serial command.

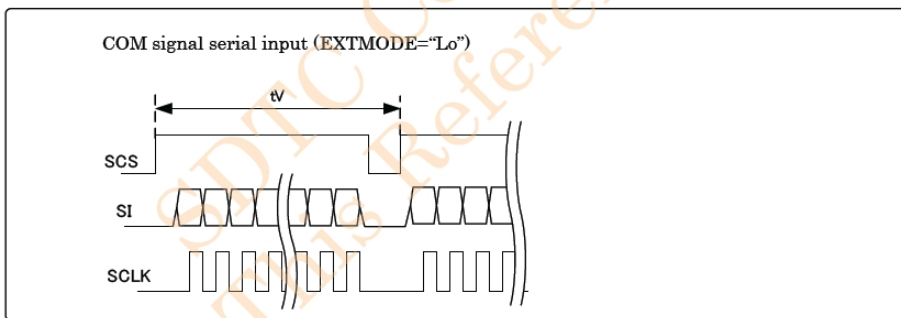

Figure 6-3-1 COM Signal Timing

【Note 6-3-2】

In case of whole lines update with COM driving by the serial command.

【Note 6-3-3】

In case of whole lines update with COM driving by the EXTCOMIN signal.

【Note 6-3-4】

Please use a frame frequency in the range where there are no problems with the display quality.

【Note 6-3-5】

LC inversion :

LC material is needed alternative polarity driving as changing timing which should be constant period.

VDDA=+3.0V, VDD=+3.0V, GND=0V, Ta=25°C							
	Item	Symbol	Min	Typ	Max	Unit	Remark
SCS	Rise time	trSCS	-	-	50	ns	
	Fall Time	tfSCS	-	-	50	ns	
	High duration	twhSCS	198	-	-	us	Data update mode [Note 6-3-6]
			22.54	-	-	us	Hold mode [Note 6-3-6]
	Low duration	twlSCS	6	-	-	us	
	Set up time	tsSCS	6	-	-	us	
	Hold time	thSCS	2	-	-	us	
SI	Rise time	trSI	-	-	50	ns	
	Fall time	tfSI	-	-	50	ns	
	Set up time	tsSI	250	-	-	ns	
	Hold time	thSI	350	-	-	ns	
SCLK	Clock frequency	fSCLK	-	1	1.1	MHz	
	Rise time	trSCLK	-	-	50	ns	
	Fall time	tfSCLK	-	-	50	ns	
	High duration	twhSCLK	454.55	500	-	ns	
	Low duration	twlSCLK	454.55	500	-	ns	
EXTCOMIN	Frequency	fEXTCOMIN	57	60	90	Hz	[Note 6-3-5]
	Rise time	trEXTCOMIN	-	-	50	ns	
	Fall time	tfEXTCOMIN	-	-	50	ns	
	High duration	twhEXTCOMIN	2	-	-	us	
DISP	Rise time	trDISP	-	-	50	ns	
	Fall time	tfDISP	-	-	50	ns	

## 【Note 6-3-6】

Please keep SCS in the state of L when you maintain current display after writing of the display data.

Signal Timing

※SCS,SI,SCLK,DISP,EXTCOMIN: 3V input voltage

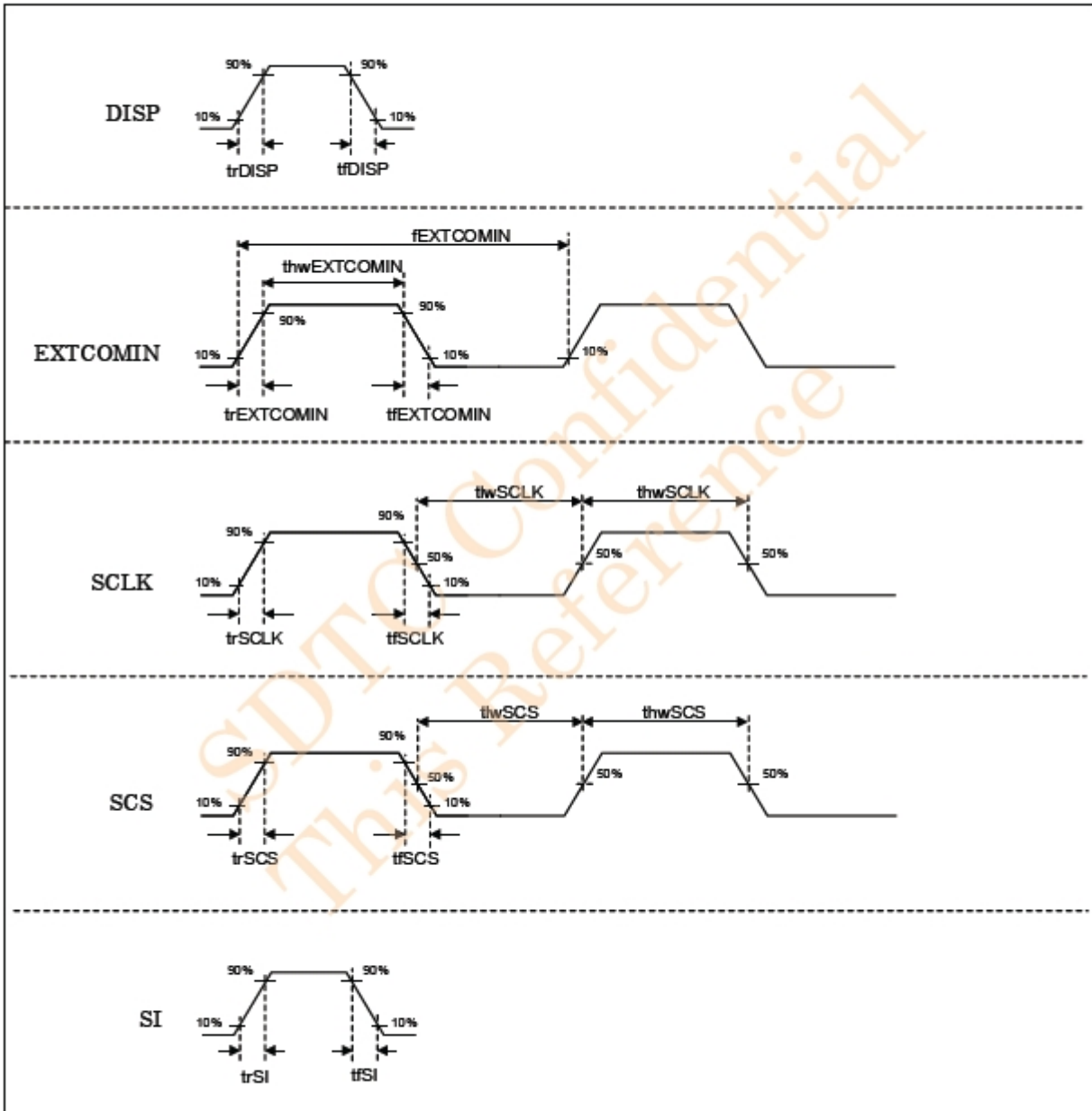

Figure 6-4-1 Signal Timing

※SCS,SI,SCLK,DISP,EXTCOMIN: 3V input voltage

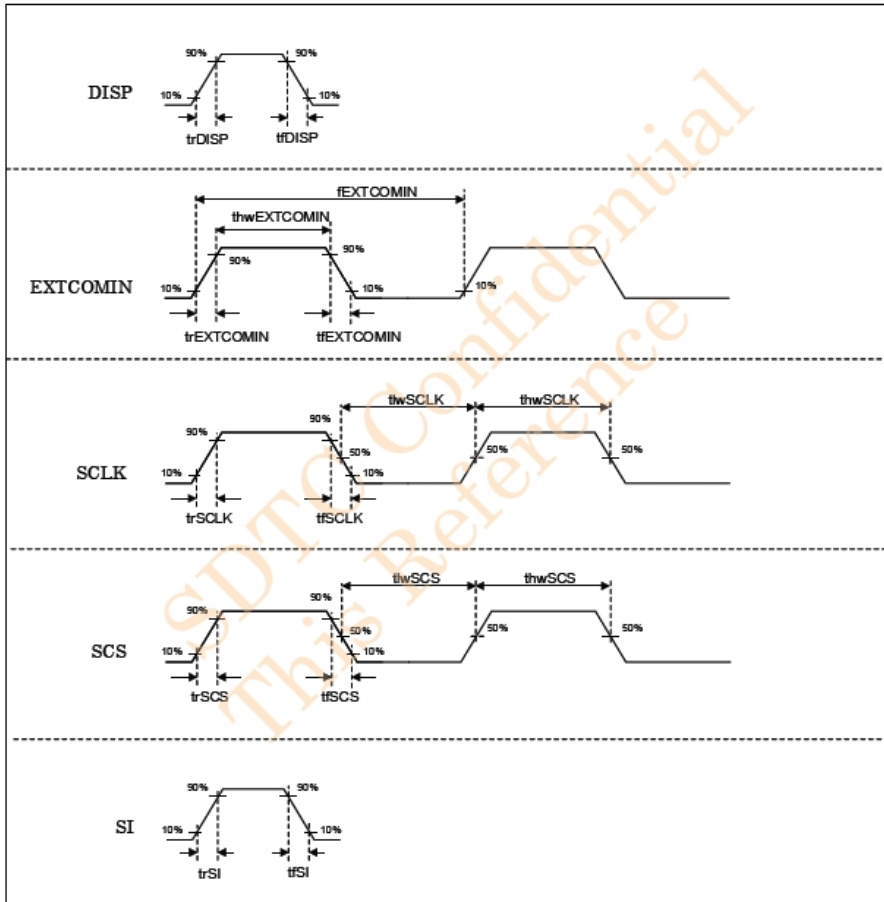
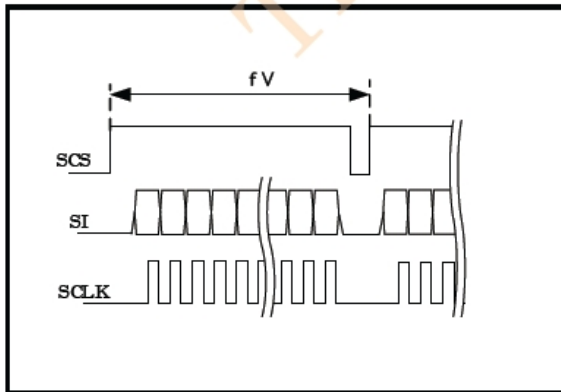

Figure 6-4-1 Signal Timing



COM signal serial input (EXTMODE="Lo")

Figure 6-4-4 Signal Timing-4

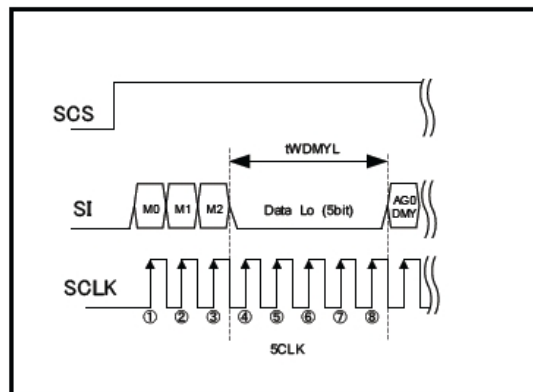

Figure 6-4-5 Signal Timing-5

**9 Test**

No change on display and in operation under the following test condition.

Condition: Unless otherwise specified, tests will be conducted under the following condition.

Temperature: 20°C±5°C.

Humidity: 65%±5%RH.

Tests will be not conducted under functioning state.

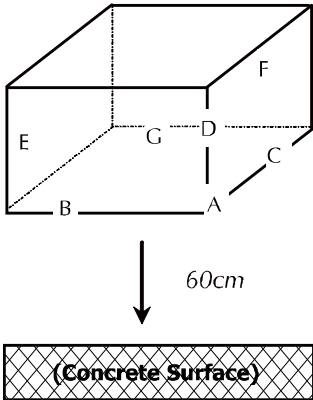
No.	Parameter	Condition	Notes
1	High Temperature Operating	+70°C±2°C, 240hrs (Operation state).	
2	Low Temperature Operating	-20°C±2°C, 240hrs (Operation state).	1
3	High Temperature Storage	+80°C±2°C, 240hrs.	2
4	Low Temperature Storage	-30°C±2°C, 240hrs.	1,2
5	High Temperature and High Humidity Operation Test	60°C±2°C, 90%, 240hrs	1,2
6	Vibration Test	Total fixed amplitude: 1.5mm. Vibration Frequency: 10~55Hz. One cycle 60 seconds to 3 direction of X, Y, Z each 15 minutes.	3
7	Electro Static Discharge Test (non-operating)	Panel Surface/Top Case: 150pF, 330 ohm Air: ±12kV, Contact: ±6kV	
8	Drop Test	To be measured after dropping from 60cm high on the concrete surface in packing state.  <i>Dropping method corner dropping:</i> <i>A corner: Once edge dropping.</i> <i>B, C, D edge: Once face dropping.</i> <i>E, F, G face: Once.</i>	

- Notes:
1. No dew condensation to be observed.
  2. The function test shall be conducted after 4 hours storage at the normal temperature and humidity after removed from the test chamber.
  3. Vibration test will be conducted to the product itself without putting I in a container.

10 Dimensional Outlines

NO.	Pin Define
1	SCLK
2	SI
3	SGS
4	EXTCOMIN
5	DISP
6	VDDA
7	VDD
8	EXTMODE
9	VSS
10	VSSA

Pin	Assignment
1	K2
2	K1
3	A
4	A

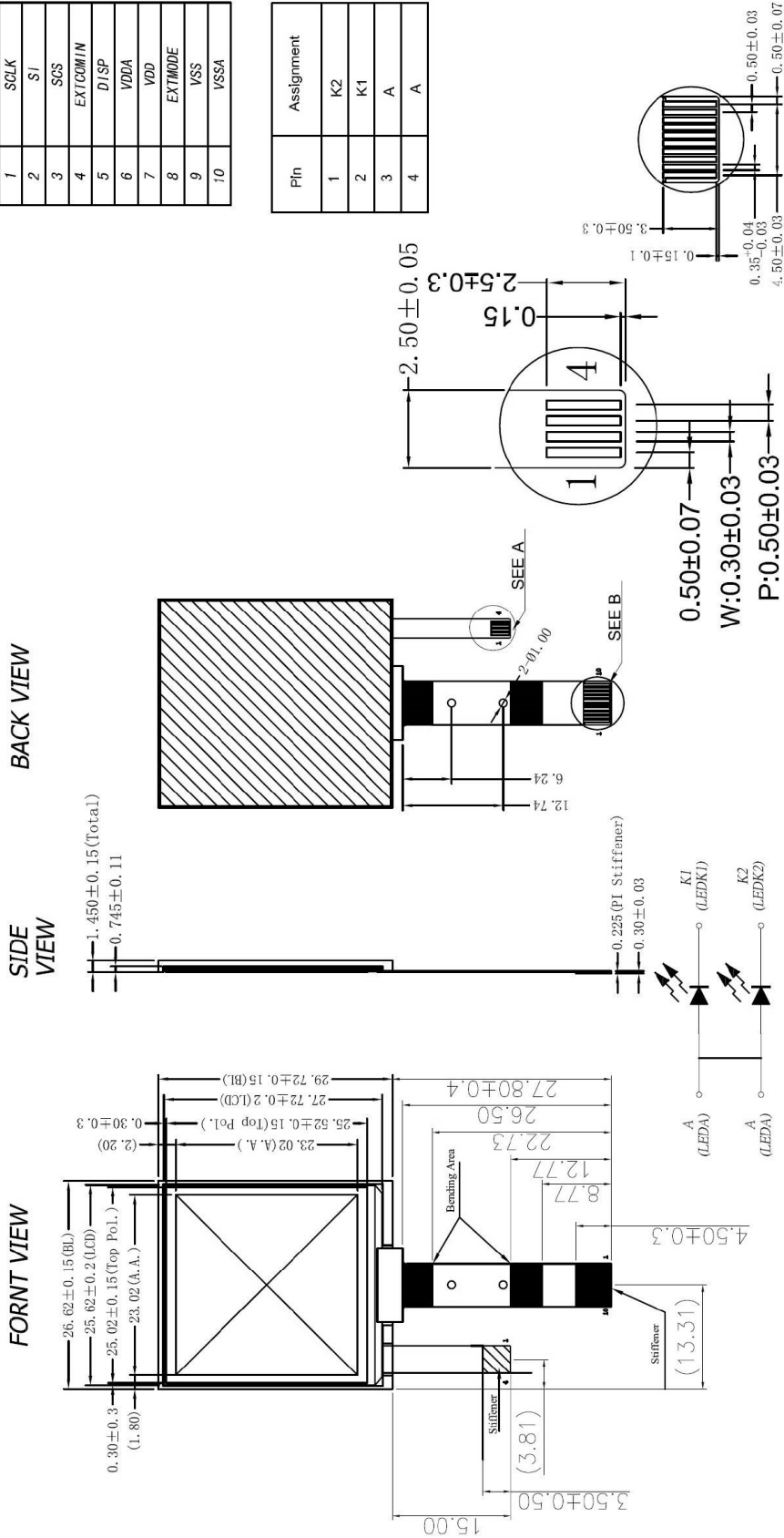

Detail B (2:1)

Detail A (4:1)

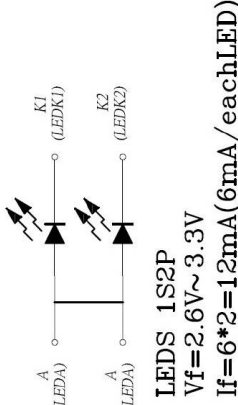

**11 Incoming Inspection Standards**

**11.1 Inspection and Environment Conditions**

**11.1.1 Inspection Conditions:**

- (1) Inspection Distance: 35 cm±5cm
- (2) View Angle : Light-on Inspection Angle : ±5°

Cosmetic Inspection Angle : ±45°

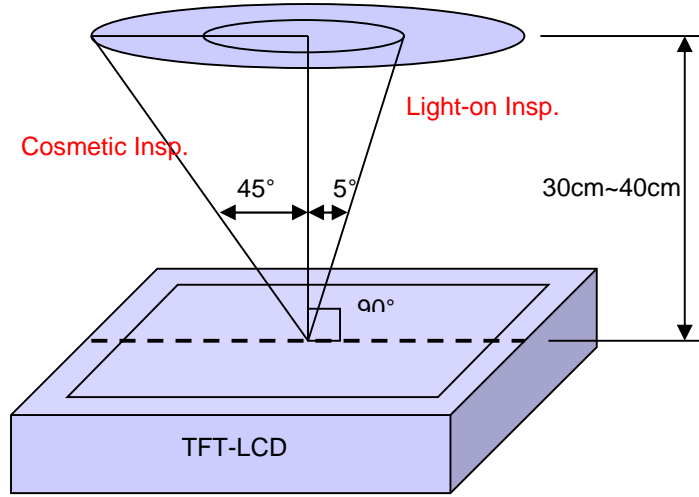

( perpendicular to LCD panel surface)

**11.1.2 Environment Conditions:**

Ambient Temperature		20~25°C
Ambient Humidity		50~80%RH
Ambient Illumination	Cosmetic Inspection	125±25 Lux
	Functional Inspection	125±25 Lux

**11.1.3 Sampling Conditions:**

- (1) Lot Size: Quantity of shipment lot per model
- (2) Sampling Method:

Sampling Plan		MIL-STD-105E
		Normal Inspection, Single Sampling
		Level II
AQL	Major Defect	1.0%
	Minor Defect	1.5%

- (3) The classification of Major(MA) and Minor(MI) defects is shown as 3. Inspection Criteria.

11.1.4 Inspection Criteria

11.1.4.1 Glass edge crack/chip

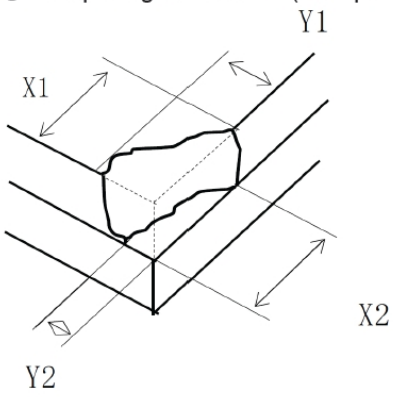
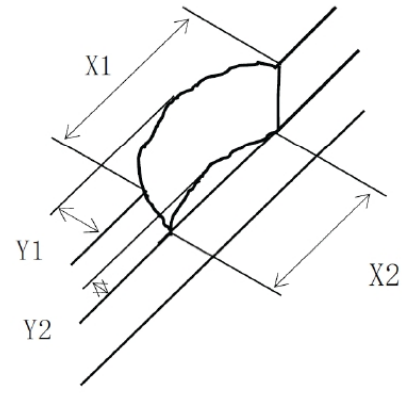
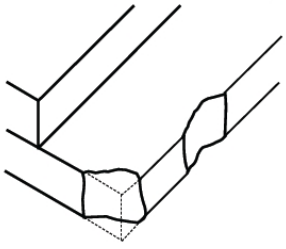
Items	Inspection criteria (Acceptable level)
<p>① Chip on glass corner (except terminal part)</p> 	<ul style="list-style-type: none"> <li>• <math>X1 \leq 0.5\text{mm}</math> and <math>Y1 \leq 5.0\text{mm}</math> or <math>X1 \leq 5.0\text{mm}</math> and <math>Y1 \leq 0.5\text{mm}</math> (However, <math>X1+Y1 \leq 5.0\text{mm}</math>)</li> <li>• <math>X2 \leq 0.5\text{mm}</math> and <math>Y2 \leq 5.0\text{mm}</math> or <math>X2 \leq 5.0\text{mm}</math> and <math>Y2 \leq 0.5\text{mm}</math> (However, <math>X2+Y2 \leq 5.0\text{mm}</math>)</li> <li>• No crack/chip at BM area</li> </ul>
<p>② Chip on glass edge (except terminal part)</p> 	<ul style="list-style-type: none"> <li>• <math>X1 \leq 10.0\text{mm}</math> and <math>X2 \leq 10.0\text{mm}</math></li> <li>• <math>Y1 \leq 0.3\text{mm}</math> and <math>Y2 \leq 0.3\text{mm}</math></li> </ul>
<p>③ Chip on the terminal glass</p> 	<ul style="list-style-type: none"> <li>• FPC and/or circuit pattern shall not be affected.</li> <li>• Crack and/or Chip shall not reach the circuit pattern.</li> </ul>

11.1.4.2 Panel burr

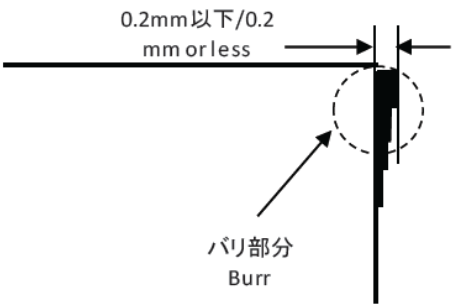
Items	Judgment criteria
<p>Panel burr (common to all the edges of the front and rear sides)</p>  <p>0.2mm以下/0.2 mm or less</p> <p>バリ部分 Burr</p>	<p>Included in the dimensional tolerance.</p>

11.1.4.3 Dot Defect

Item	Allowable number
White dot	1
Black dot	1
Total(White dot+Black dot)	2

11.1.4.4 Cosmetic items

Item	Judgment Criteria			Classification
	Area(Note1)	I	O	
Point Defect	Bright dot	Random	2	
		2 dots adjacent	0	0
		3 dots adjacent or more	0	0
	Dark dot	Random	3	
		2 dots adjacent	0	
		3 dots adjacent or more	0	0
	Total Dot Defect		5	
	Distance	Distance between Bright and Bright dot	$L \geq 5\text{mm}$	
		Distance between Bright and Dark dot	$L \geq 5\text{mm}$	
		Distance between Dark dot	$L \geq 5\text{mm}$	
(1) It is defined as Point Defect if defect area > 0.5dot (2) It is ignored if defect area $\leq 0.5\text{dot}$ (3) Weak point defect will be defined as Bright Dot if it can be observed through ND filter 5%( Full Screen Black Inspection)				
Line Defect	Obvious vertical or horizontal line defect is not allowed.			MA
Mura	Not allowed if it can be observed through ND Filter 5 %			MI
Foreign Material in spot shape *Note-3	$D \leq 0.1\text{mm}$ : Ignored $0.1\text{mm} < D \leq 0.3\text{mm}$ : $N \leq 3$ $D > 0.3\text{mm}$ : Not allowed			MI
Foreign Material in line or spiral shape *Note-4	$W \leq 0.1\text{mm}$ or $L \leq 3\text{mm}$ : Ignored $0.1\text{mm} < W \leq 0.2\text{mm}$ and $3.0\text{mm} < L \leq 5\text{mm}$ : $N \leq 3$ $W > 0.2\text{mm}$ or $L > 5\text{mm}$ : Not allowed			MI
Display Function Abnormal	No Malfunction can be allowed			MA

Note-1 : I/O Area Definition      Note-2 : Polarizer Scratch

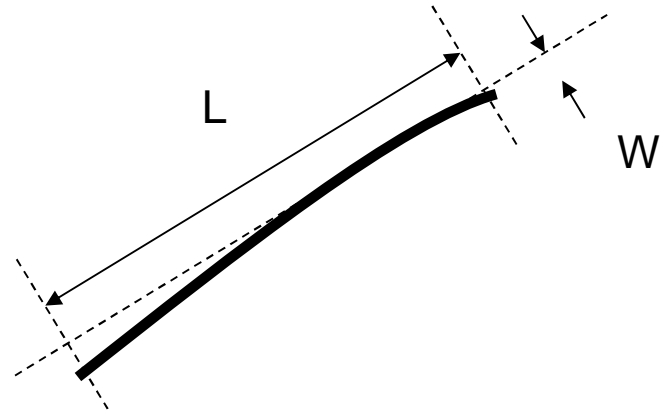
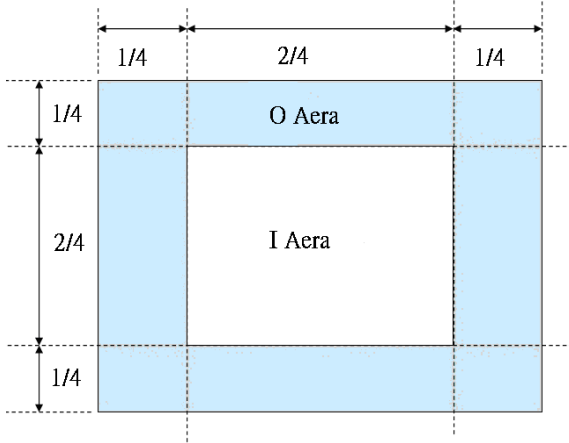

Note-3 : Spot Foreign Material  
( $W \geq L / 4$ )

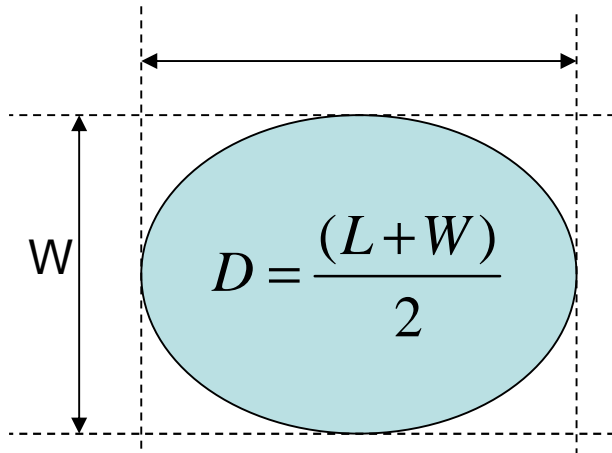

Note-4 : Line or Spiral Foreign Material  
( $W < L / 4$ )

