

DISPLAY Elektronik GmbH

DATA SHEET

MIP-DISPLAY

DE MIP160068A-W

(1,08" Memory in Pixel, Mono)

Product Specification

Version: 0

09.04.2025

Revision History

VERSION	DATE	REVISED PAGE NO.	Note
0	09.04.2025		First Release

Contents

1. Applicable Memory Liquid Crystal Display
2. Overview
3. Mechanical Specification
4. Input Terminal Names and Functions
5. Absolute Maximum Ratings
6. Electrical Characteristics
7. Optical Specification
8. Pin Assignment
9. Display Qualities
10. External Capacitors
11. Reliability Test Conditions
12. Outline Dimensions

1. Applicable Memory Liquid Crystal Display

This TFT-LCD Module is a reflective Active-Matrix with slightly transmissive memory liquid crystal display module with CG-Silicone Thin Film Transistor Module outline is indicated in Figure 14-1

2. Overview

- Reflective Active-Matrix with slightly transmissive Panel of White and Black.
- 1.08" Screen has 160 x 68 Dots resolution.
- 1 Pixel has each 1bit, the Pixel can display 2 Colors.
- Display Control by Serial Data Signal Communication.
- Arbitrary Line Data renewable.
- 1bit internal Memory for Data Storage within the Panel.
- Thin, light-weight and compact Module with monolithic technology.
- Super Low Power Consumption TFT Panel.
- Front Polarizer Surface is HardCoat.
- With FPC (Applicable Connector: Ref to recommended connector on Table 8-1)

3. Mechanical Specification

Table 3-1 Module

ITEM	SPECIFICATION	UNIT
Screen Size	1.08"	Inch
Active Area	25.28 x 10.744	mm
Dot Configuration	160 x 68	Dot
Dot Pitch	0.158 x 0.158	mm
Pixel Array	Square	-
Display Mode	MIP, Normally White	-
Outline Dimensions	32.00 x 14.00 x 0.725	mm
Weight	0.73	g
Surface Treatment	HC (Hard-Coated)	-

- Note:
1. Outline Dimension: WxHxD
 2. Weight: typ.
 3. Detail Dimension and tolerance are shown in Figure 14-1

4. Input Terminal Names and Functions

Table 4-1 Pin description

Terminal	Symbol	I/O	Configurations	Function	Remark
1	SCLK	INPUT	NoPull	Serial clock signal	
2	SI	INPUT	NoPull	Serial data input signal	
3	SCS	INPUT	NoPull	Chip select signal (Active of Hi)	
4	EXTCOMIN	INPUT	NoPull	External COM inversion signal input (Square wave)	Note 4-2
5	DISP	INPUT	NoPull	ON/OFF Display ON/OFF signal	Note 4-1
6	VDDA	POWER	—	Power supply (Analog)	Note 4-4
7	VDD	POWER	—	Power supply (Digital)	Note 4-4
8	EXTMODE	INPUT	NoPull	Control mode of COM inversion is select terminal	Note 4-2
9	VSS	GND	—	GND (Digital)	Note 4-3
10	VSSA	GND	—	GND (Analog)	Note 4-3

General Note: Neither Pulled up nor Pulled down.

The input terminals must not be in an indeterminate state (HiZ).

Note 4-1: The display ON/OFF signal is only for display.

Data on the memory will be saved at the time of ON/OFF.

When it's "Hi" data in the memory will display, when it's "Lo", white color will display and data in the memory will be saved.

Note 4-2: When EXTMODE is "Hi", EXTCOMIN signal is enable.

When EXTMODE is "Lo", serial input flag is enable.

"Hi" Mode: Connect the EXTMODE to VDD

"Lo" Mode: Connect the EXTMODE and EXTCOMIN to VSS

Note 4-3 Be sure to connect VSS and VSSA on the board.

(Connection near the connector is recommended)

Note 4-4 VDD ≥ VDDA

4.1 Input Signal States

Table 4-1-1 Input Signal States

Symbol	I/O	Voltage (V)	起動時 Boot	データ更新 (Update & Hold mode)	スタンバイ状態 Standby	備考 note
SCLK	Input	0 / 3.0	Lo	Hi / Lo (Enter clk)	Lo	EXTMODE=Hi
					Hi / Lo (Enter clk)	EXTMODE=Lo Note 4-1-1
SI	Input	0 / 3.0	Lo	Hi / Lo (Enter data)	Lo	EXTMODE=Hi
					Hi / Lo (Enter data)	EXTMODE=Lo Note 4-1-1
SCS	Input	0 / 3.0	Lo	Hi (Enter data)	Lo	EXTMODE=Hi
					Hi / Lo (Enter data)	EXTMODE=Lo Note 4-1-1
EXTCOMIN	Input	0 / 3.0	Lo	Hi / Lo (Input pulse (CLK) Signal.)	Hi / Lo (Input pulse (CLK) Signal.)	EXTMODE=Hi Note 4-1-2
				Lo	Lo	EXTMODE=Lo
DISP	Input	0 / 3.0	Lo	Hi / (Lo)	Hi / (Lo)	Note 4-1-3
EXTMODE	Input	0 / 3.0		Hi / Lo (Change is not permitted)		Note 4-1-4

Common condition

- 1) Each Voltage values show typical voltage.
- 2) Booting
 - ・When just input Power supply Between PowerON and Input Signal.
- 3) Data Update & Hold mode
 - ・ Updates data in pixel memory. (1Line and Multiple Lines update)
- 4) Standby
 - ・ Maintains memory internal data and maintain current display
- 5) Keep "Lo" Serial Signal (SCS / SI / SCLK) without communicating.
 - ・ Not to make a SCS terminal "Hi" when it does not communicate.
- 6) VDD ≥ VDDA, VSS = VSSA = GND = 0V

[Note 4-1-1] :

To do VCOM control in a serial communication, a periodic signal transmission is necessary and is here.

[Note 4-1-2] :

Input (Clock pulse) is always needed during displaying.

[Note 4-1-3] :

When displaying it, it's driven "Hi" fixing.

[Note 4-1-4] :

Fixed to Hi or Lo. Recommend to connect VDD or GND (VSS)
Not change after starting power supply and during ON.

4.2 Recommended Circuit

4-2) Recommended Circuit

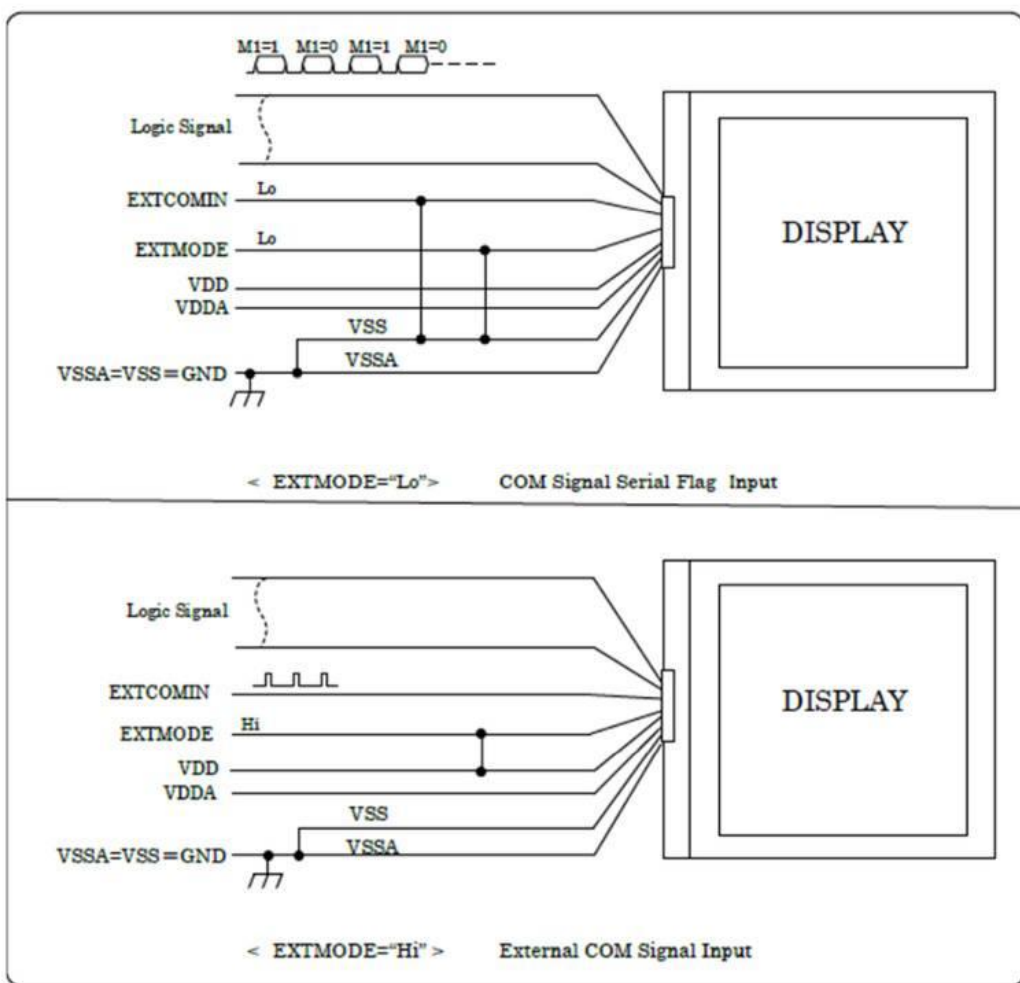

Figure 4-2-1 Recommended circuit

5 Absolute Maximum Rating

Table 5-1 Absolute Maximum Rating

(GND = 0V)							
Item	Symbol	Terminal	MIN.	MAX.	Unit	Remark	
Power supply voltage	V_VDDA	VDDA	-0.3	+3.6	V	Note 5-1	
	V_VDD	VDD	-0.3	+3.6	V	Note 5-1	
	V_VSS	VSS , VSSA	0	0	V		
Input signal voltage	High Level	V_IH	SCLK , SI , SCS DISP , EXTCOMIN EXTMODE	-	VDD	V	
	Low Level	V_IL		-0.3	-	V	
Storage Temperature	Tstg	-	-30	+ 80	°C	Note 5-2 Note 5-3	
Operation Temperature (at panel surface)	Topr	-	-20	+ 70	°C	Note 5-3 Note 5-4	

※ The absolute maximum rating is the limit value.

[General Note] Above Voltage value is a value based on VSS / VSSA (GND = 0V)
VSS=VSSA=GND

[Note 5-1] $VDD \geq VDDA$

[Note 5-2]
Do not exceed this temperature in any parts of module.

[Note 5-3

Humidity 95%RH Max. ($T_a \leq 40^\circ\text{C}$) Attention should be paid to static electricity Maximum wet bulb temperature is 39°C or lower. No condensation is allowed.
Condensation will cause electrical leak and may cause the module to not meet this specification.

[Note 5-4

Operating temperature is the temperature that guarantees only for the operation.
For contrast, response time, and other display quality determination, use $T_a = +25^\circ\text{C}$.

6 Electrical Characteristics

6.1 TFT LCD Panel Drive

Table 6-1-1 推奨駆動条件 Recommended operating Condition

(GND = 0V), Ta = +25°C

Item	Symbol	Terminal	Min.	Typ.	Max.	Unit	Remark
Power supply Voltage	VVDDA	VDDA	+2.7	+3.0	+3.3	V	Note 6-1-1
	VVDD	VDD	+2.7	+3.0	+3.3	V	Note 6-1-1
	VVSS	VSS, VSSA	0	0	0	V	
Input signal voltage	High Level	VIH	SCLK, SI, SCS DISP, EXTCOMIN	VDD-0.1	VDD	VDD	V
			EXTMODE	VDD	VDD	VDD	V
	Low Level	VIL	SCLK, SI, SCS DISP, EXTCOMIN EXTMODE	VSS	VSS	VSS+0.1	V

[General Note] Above Voltage value is a value based on VSS / VSSA (GND = 0V)
VSS=VSSA=GND

[Note 6-1-1] VDD ≥ VDDA

6.2 Power Supply Sequence

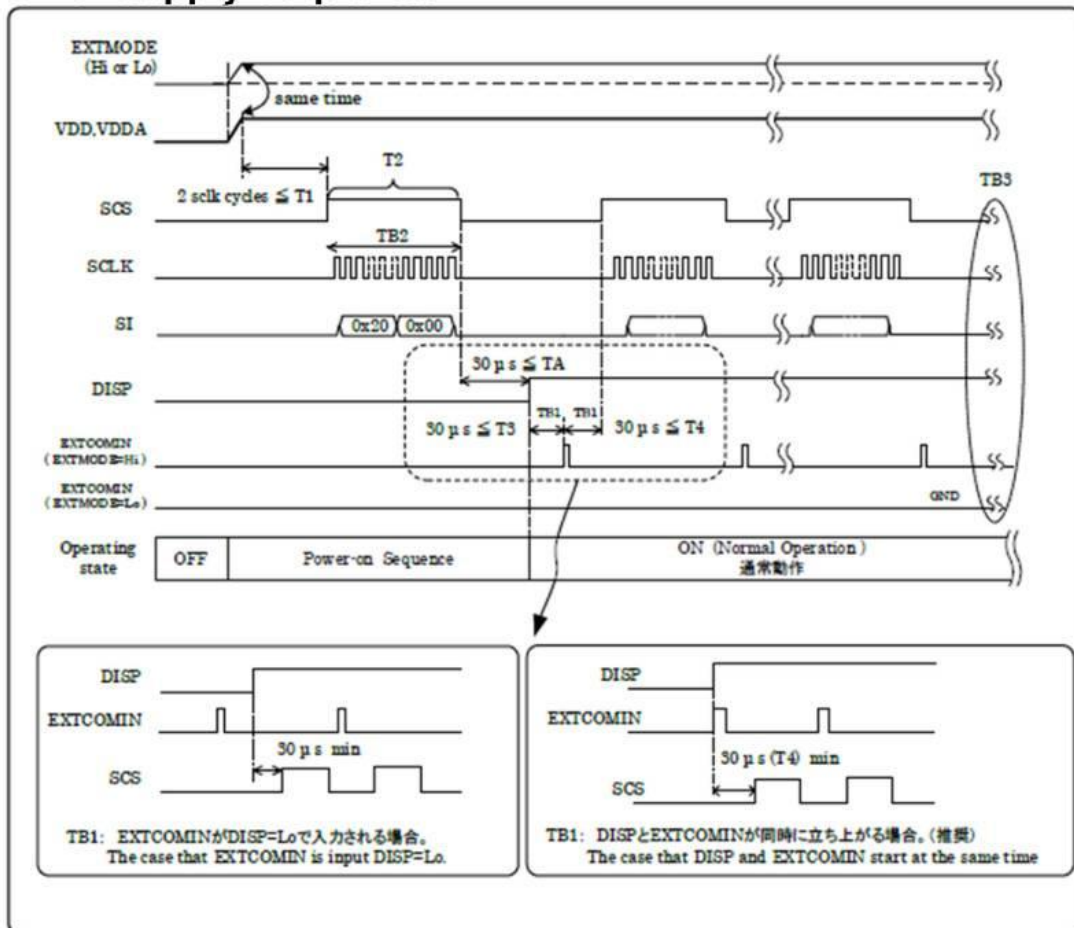

Figure 6-2-1 Power supply sequence

Refer to timing chart and AC timing characteristics for detail

[Note]

Precautions at the time of power on and power off.

When power on , VDD and VDDA are same time or VDD should be faster than the VDDA.

When power off, VDD and VDDA are same time or VDDA should be faster than the VDD.

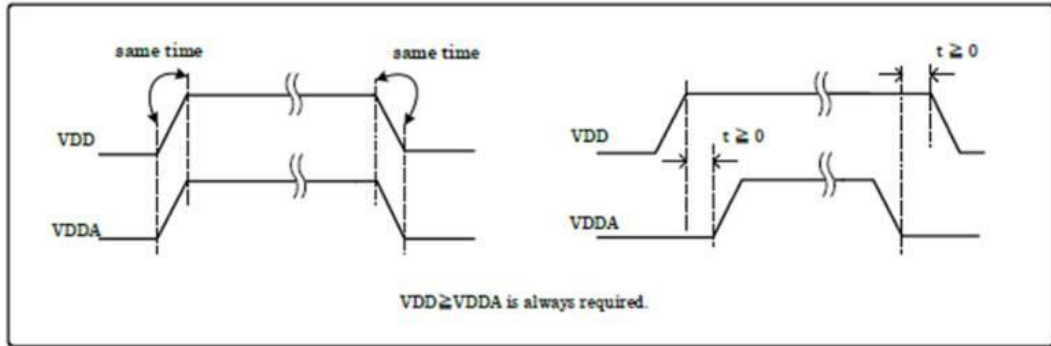

Figure 6-2-2 Power supply sequence

T1 : Please start the Signal transmission after a power supply was stable.

TA : Please set DISP to High Level after the completion of initialization.

TB1 :

TA and T3 may be opposite
 (however, TCOM polarity inversion will not occur even with EXTCOMIN between DISP= "Lo".)
 Also, when DISP and EXTCOMIN are simultaneously started up, allow 30us or more before SCS starts up. (It may be less than 60us).

TB2

Setting value for pixel memory initialization.
 SCS=Driving accordingly to clear pixel internal memory method.
 (use all clear flag or write all screen white)
 S1=M2 (all clear flag) = "Hi" or write white.
 SCLK : Normal Driving

TB3 : SCSLK , SCS , S1 "Lo"
 ·DISP ON "Hi"
 ·EXTCOMIN
 EXTMODE= Lo "Lo"
 EXTMODE= Hi

•EXTMODE Hi / Lo

•Make SCLK,SI and SCS terminals "Lo" while it does not communicate.

•Keep "Hi" DISP terminal ,when power supply on (VDD).

•EXTCOMIN terminal

 This is valid the case of EXTMODE= "Lo" as EXTCOMIN= "Lo".

 This is valid the case of EXTMODE= "Hi" a periodic signal input is necessary.

•Not change (Hi to Lo or Lo to Hi) after starting power supply and during ON

[ON Sequence]

1) VDD,VDDA (IC)
VDD and VDDA rise time (depends on IC).

(2)

T2 : 1 M2

Pixel memory initialization

T2 : 1 time or more Initialize with M2 (all clear flag) or write all screen white.

(3) TCOM T3 : 30us

DISP COM

Release time for initialization of TCOM latch

T3 : 30us or more

Time required to release COM related latch circuit initialization which is initializing using DISP Signals.

(4) TCOM T4 : 30us

EXTCOMIN ICOM

TCOM polarity initialization time. T4 : 30us or more

Time required initializing TCOM polarity accordingly to EXTCOMIN input.

[Normal Operation]

Duration of normal driving.

6.3 Input Signal Timing Parameters

Table 6-3-1 Input Signal timing Parameters

VDDA = +3.0V, VDD = +3.0V, GND = 0V, Ta = 25°C

Signal	Item	Symbol	Min	Typ	Max	Unit	Remark
SCS	Rise time	trSCS	-	-	50	ns	
	Fall Time	tfSCS	-	-	50	ns	
	SCS frequency	fSCS	-	-	70	Hz	Full screen update Note 6-3-1 Note 6-3-2
	High duration	twhSCS	182.54	-	-	μs	Data update mode Note 6-3-1
			22.54	-	-	μs	Hold mode Note 6-3-1
	Low duration	twlSCS	6	-	-	μs	
	Set up time	tsSCS	6	-	-	μs	
Hold time	thSCS	2	-	-	μs		
SI	Rise time	trSI	-	-	50	ns	
	Fall time	tfSI	-	-	50	ns	
	Set up time	tsSI	250	-	-	ns	
	Hold time	thSI	350	-	-	ns	
SCLK	Clock frequency	fSCLK	-	1.0	1.1	MHz	
	Rise time	trSCLK	-	-	50	ns	
	Fall time	tfSCLK	-	-	50	ns	
	High duration	twhSCLK	404.55	450	-	ns	
	Low duration	twlSCLK	404.55	450	-	ns	
EXTCOMIN	Frequency	fEXTCOMIN	57	60	70	Hz	
	Rise time	trEXTCOMIN	-	-	50	ns	
	Fall time	tfEXTCOMIN	-	-	50	ns	
	High duration	twhEXTCOMIN	2	-	-	μs	
DISP	Rise time	trDISP	-	-	50	ns	
	Fall time	tfDISP	-	-	50	ns	

[Note 6-3-1]

Please keep SCS in the state of "Lo" when you maintain current display after writing of the display data.

[Note 6-3-2]

This spec applies only to full screen updates.

In updating only specific lines, this spec does not apply. Therefore, please design based on other timing specifications.

※SCS , SI , SCLK , DISP , EXTCOMIN : 3.0V input voltage

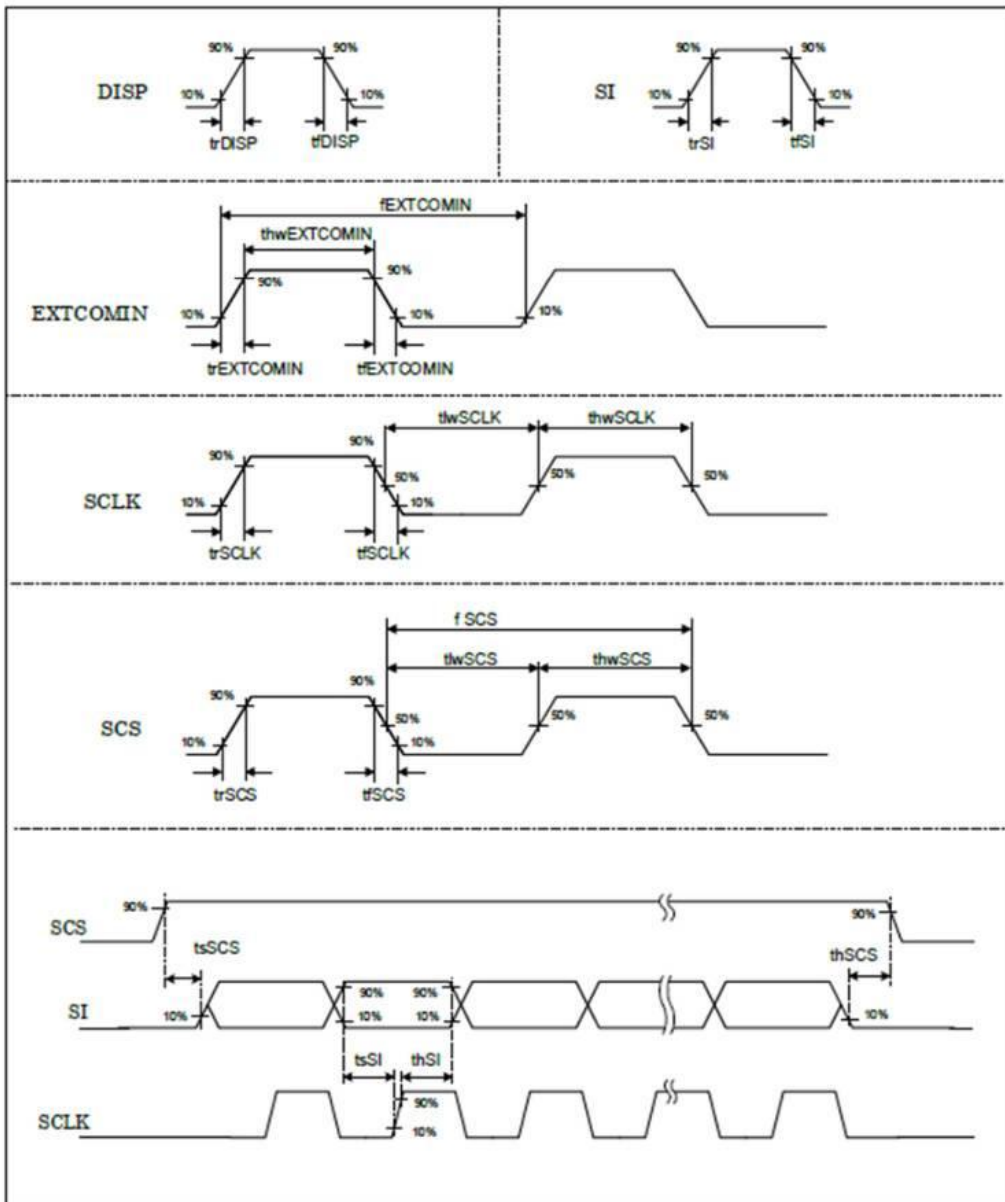

Figure 6-3-1

AC timing characteristics diagram

6.4 Power Consumption

Table 6-4-1

Current Consumption

Input signal voltage (high) = +3.0 V , VDD = +3.0 V , VDDA = +3.0 V , Ta = 25°C

Condition	Power consumption		Min	Typ	Max	Unit	Remark
Condition 1	Operating Mode	HOLD (no display data update)	-	15	50	μW	Note 6-4-1
	Display pattern	Black display					
Condition 2	Operating Mode	Data update modewith display update (1fram / sec)	-	25	100	μW	Note 6-4-2
	Display pattern	Vertical stripe display					

‡ Common condition

VDD = 3.0V, VDDA = 3.0V, fCLK = 1.0MHz, EXTMODE = VDD, EXTCOMIN = 60Hz

Update data on all screens.

Formula for computation

$$(I_{vdd} + I_{vdda}) [\mu A] \times 3.0 [V]$$

(Common Note)

This is value in steady condition, not the falue of peak power at the time of COM operation.

Some marging for power supply is recommended.

We recommend capacitor for VDD and VDDA.

(If VDD and VDDA are on separate systems, we recommend capacitor for each.)

[Note 6-4-1]

Condition 1 : Current measurement period of power supply.

tI_condition 1 :

Measurement time shall be EXTCOMIN cycles, at least 2 cycles..

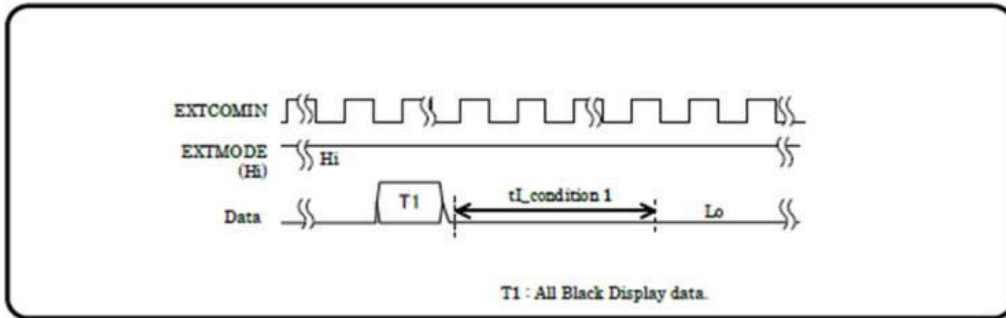

Figure 6-4-1 Current measurement 1

[Note 6-4-2]

Condition 2 : Current measurement period of power supply.

tI_condition 2 :

Measurement time is 1 sec.

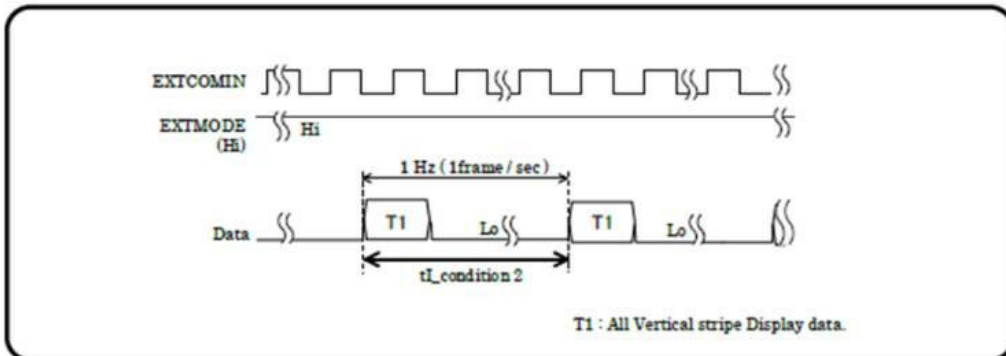

Figure 6-4-2 Current measurement 2

6.5 Input Signal Characteristics

6-5-1)

COM control can be done by serial data or by EXTCOMIN signal.

[General Note 6-5-1]

Please use a frame frequency in the range where there are no problems with the display quality.

[General Note 6-5-2]

LC inversion (COM inversion) :

LC material is needed alternative polarity driving as changing timing which should be constant period.

The conditions as an example (For EXTCOMIN = 60Hz) :

EXTMODE=Hi , SCS=Lo , EXTCOMIN = 60Hz

fEXTCOMIN frequency 60Hz is COM frequency (fCOM) 30Hz.

as shown Figure 6-5-1 (fCOM = 30Hz)

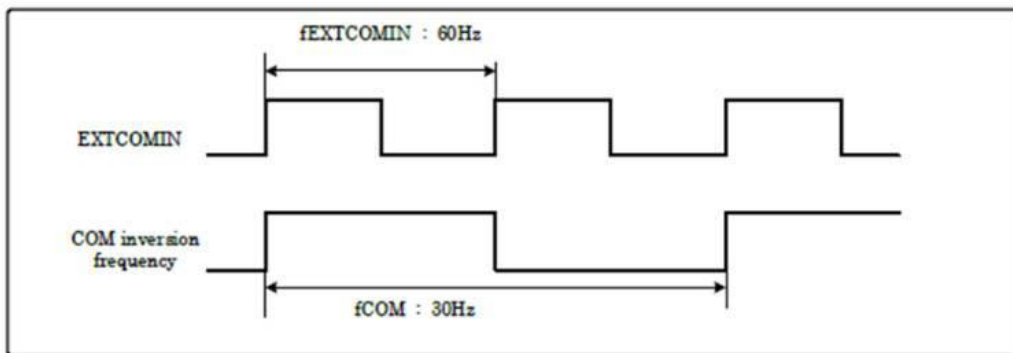

Figure 6-5-1 COM inversion frequency

6-5-2)

(When EXTMODE=Lo)

(COM driving by the serial command)

For this COM control, the M1 bit must be updated so that the COM cycle (fCOM) is constant regardless of the number of data update lines and update cycle.

For more information, see section 6-6-5).

Table6-5-1

Recommend Operating Conditions and DC Characteristics

VDDA = +3.0V, VDD = +3.0V GND = 0V, Ta = 25°C

Item	Symbol	Min	Typ	Max	Unit	Remark
COM Inversion	fV	57	—	70	Hz	Figure 6-5-1, Figure 6-6-3 Figure 6-6-5
COM frequency	fCOM	28.5	—	35	Hz	Figure 6-5-1, Figure 6-6-3 Figure 6-6-5

6-5-3)

(When EXTMODE=Hi)

(COM driving by the serial command)

For more information, see section 6-6-5).

Table6-5-2

Recommend Operating Conditions and DC Characteristics

VDDA = +3.0V, VDD = +3.0V GND = 0V, Ta = 25°C

Item	Symbol	Min	Typ	Max	Unit	Remark
COM frequency	fCOM	28.5	—	35	Hz	Figure 6-6-6, Figure 6-6-7

6.6 Input Signal Timing Chart

6-6-1

Data update mode (1 line)

Updates data of only one specified line. (M0= "Hi", M2= "Lo")

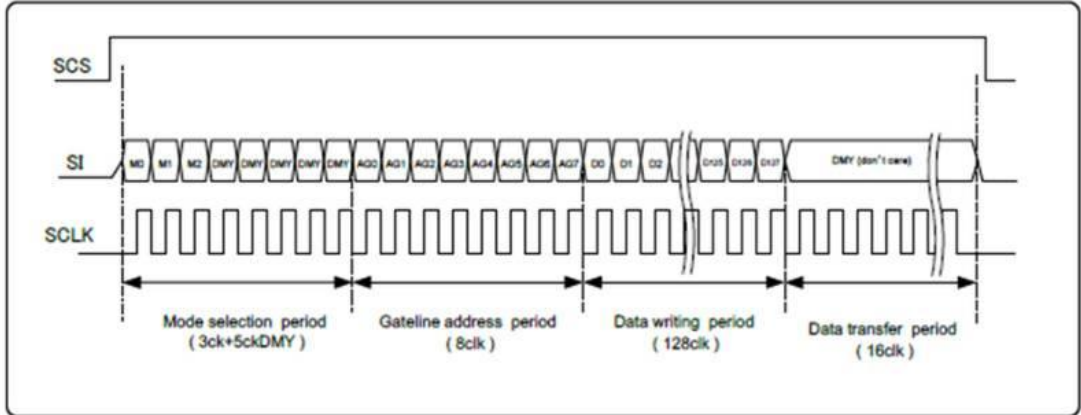

Figure 6-6-1 Data update mode by 1line

M0 : Mode flag.

Set for "Hi" : Data update mode (Memory internal data update)
 Set for "Lo" : Hold mode (maintain memory internal data)

M1 : Frame inversion flag.

When "Hi", outputs VCOM = "Hi", and when "Lo", outputs VCOM = "Lo".
 When EXTMODE = "Hi", it can be "Hi" or "Lo".

M2 : All clear flag.

Refer to 6-6-4) All Clear Mode to execute clear.

DUMMY DATA :

Dummy data : It can be "Hi" or "Lo" ("Lo" is recommended)

D0-D127 :

Writing Image data (Horizontal Line data)

Hi : (White)
 Lo : (Black)

※ Data write period Data is being stored in 1 st latch block of binary driver on panel.
※ Data transfer period Data written in 1 st latch is being transferred (written) to pixel internal memory circuit.

For gate line address setting, refer to 6-7) Input Signal and Display.

Input data continuously

M1 : Frame inversion flag is enabled when EXTMODE="Lo".

When SCS becomes "Lo", M0 and M2 are cleared.

6-6-2

Data Update Mode (Multiple Lines)

Updates arbitrary multiple lines data. (M0= "Hi", M2= "Lo")

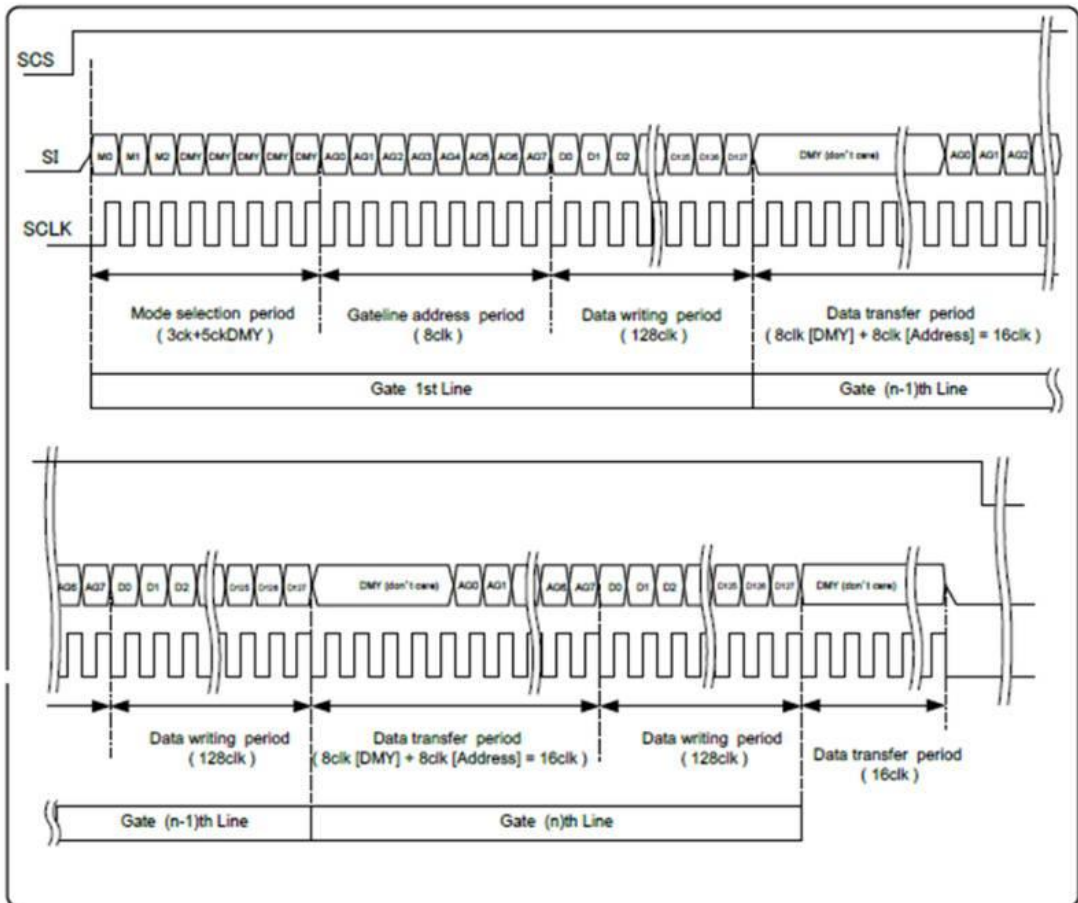

Figure 6-6-2 Data update mode by Multiple Lines

M0 : Mode flag.

Set for "Hi" : Data update mode (Memory internal data update)
 Set for "Lo" : Hold mode (maintain memory internal data).

M1 : Frame inversion flag.

When "Hi", outputs VCOM = "Hi", and when "Lo", outputs VCOM = "Lo".
 When EXTMODE = "Hi", it can be "Hi" or "Lo".

M2 : All clear flag.

Refer to 6-6-4) All Clear Mode to execute clear.

DUMMY DATA :

Dummy data : It can be "Hi" or "Lo" ("Lo" is recommended)

D0-D127 :

Writing Image data (Horizontal Line data)

Hi : (White)

Lo : (Black)

※ Data write period

Data is being stored in 1st latch block of binary driver on panel.

※ Data transfer period

For example, during GL2nd line data transfer period, GL 2nd line address is latched and GL1st line data is transferred from 1st latch to pixel internal memory circuit at the same time.

For gate line address setting, refer to 6-7) Input Signal and Display.

Input data continuously.

M1 : Frame inversion flag is enabled when EXTMODE="Lo".

When SCS becomes "Lo", M0 and M2 are cleared.

6-6-3

Hold Mode

Maintains memory internal data (maintains current display). (M0= "Lo", M2= "Lo")

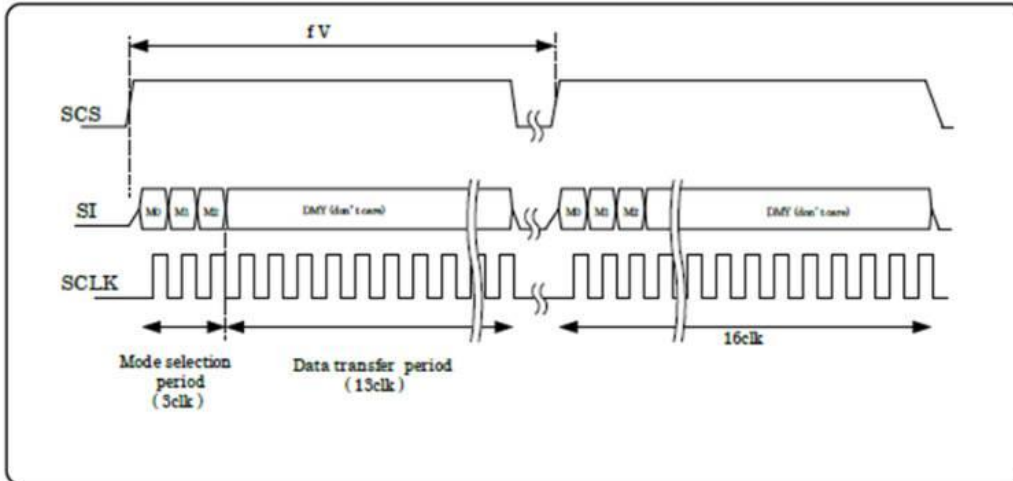

Figure 6-6-3 HOLD mode

M0 : Mode flag.

Set for "Hi" : Data update mode (Memory internal data update)
 Set for "Lo" : Hold mode (maintain memory internal data).

M1 : Frame inversion flag.

When "Hi", outputs VCOM = "Hi", and when "Lo", outputs VCOM = "Lo".
 When EXTMODE = "Hi", it can be "Hi" or "Lo".

M2 : All clear flag.

Refer to 6-6-4) All Clear Mode to execute clear.

DUMMY DATA :

Dummy data : It can be "Hi" or "Lo" ("Lo" is recommended)

M1 : Frame inversion flag is enabled when EXTMODE= "Lo".

When SCS becomes "Lo", M0 and M2 are cleared.

6-6-4

All Clear Mode

Clears memory internal data and writes white. (M0= "Lo", M2= "Hi")

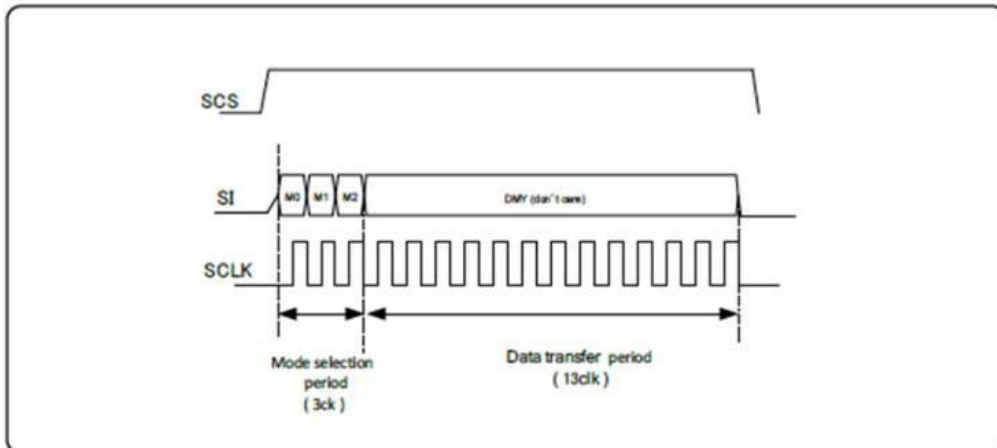

Figure 6-6-4 All Clear mode

M0 : Mode flag.

Set it "Lo".

M1 : Frame inversion flag.

When "Hi", outputs VCOM = "Hi", and when "Lo", outputs VCOM = "Lo".
When EXTMODE = "Hi", it can be "Hi" or "Lo".

M2 : All clear flag.

Set it "Hi"

DUMMY DATA :

Dummy data : It can be "Hi" or "Lo" ("Lo" is recommended)

M1 : Frame inversion flag is enabled when EXTMODE= "Lo".

When SCS becomes "Lo", M0 and M2 are cleared.

6.6 Input Signal Timing Chart

6-6-1

Data update mode (1 line)

Updates data of only one specified line. (M0= "Hi", M2= "Lo")

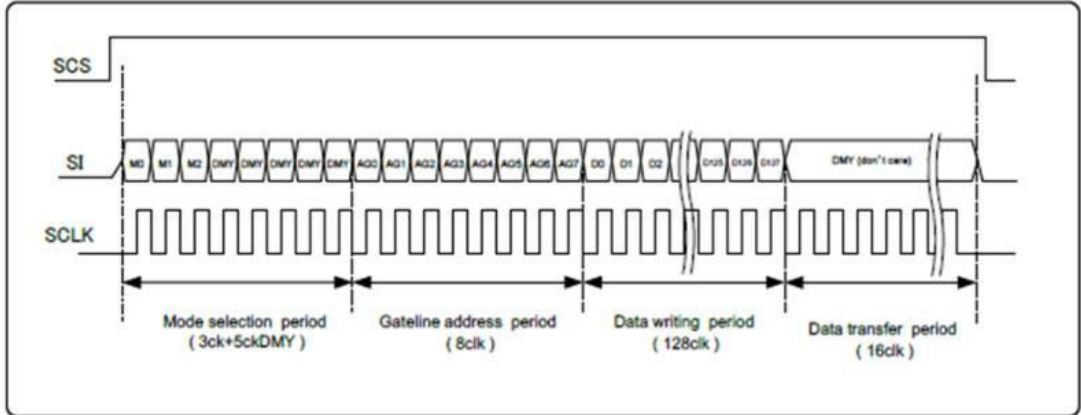

Figure 6-6-1 Data update mode by 1line

M0 : Mode flag.

Set for "Hi" : Data update mode (Memory internal data update)
 Set for "Lo" : Hold mode (maintain memory internal data)

M1 : Frame inversion flag.

When "Hi", outputs VCOM = "Hi", and when "Lo", outputs VCOM = "Lo".
 When EXTMODE = "Hi", it can be "Hi" or "Lo".

M2 : All clear flag.

Refer to 6-6-4) All Clear Mode to execute clear.

DUMMY DATA :

Dummy data : It can be "Hi" or "Lo" ("Lo" is recommended)

D0-D127 :

Writing Image data (Horizontal Line data)

Hi : (White)
 Lo : (Black)

EXTMODE="Hi" (COM inversion timing has two conditions)

① EXTCOMIN input during high period of the SCS signal

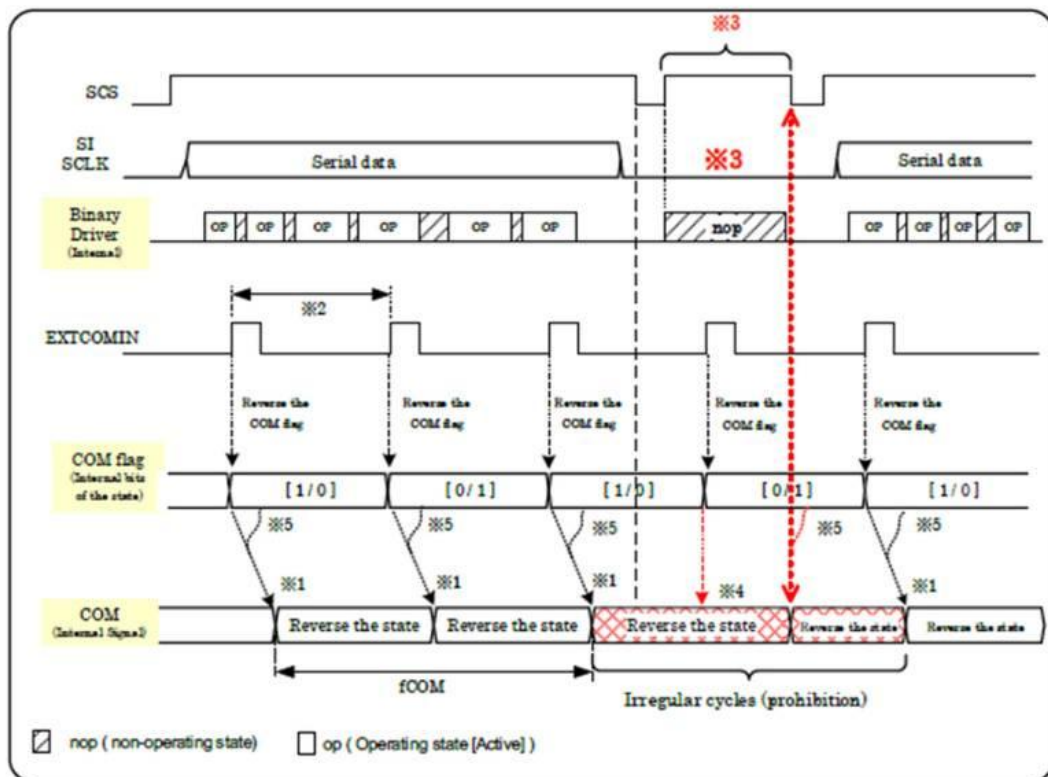

Figure 6-6-6 COM Inversion (EXTMODE=Hi) 1

[Note 6-6-1]

Inversion at EXTCOMIN rising edge.

Make "COM" reversal depending.

The period of EXTCOMIN should be constant and the period of COM inversion should be constant depending on EXTCOMIN. (with Send a serial data or making the period of "SCS= Low")

The signal timing which isn't good.
 Do not set SCS to Hi (1) if data is not to be transmitted

COM inversion does not occur. (State is preserved)

COM Flag-bit and COM inversion on the rising edge of EXTCOMIN.

Table 6-6-2 COM state 2 (EXTMODE=Hi and SCS=Hi)

		COM state (COM flag state) [note 6-6-1]	
		State before inversion	Status after inversion
SCS=Hi	Hi		0
			1

② EXTCOMIN input during low period of the SCS signal

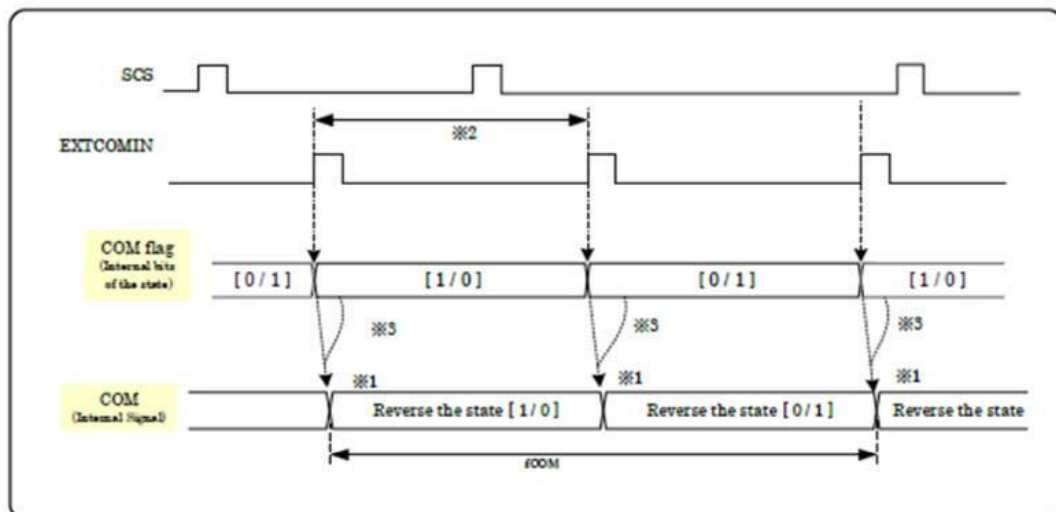



Figure 6-6-7 COM Inversion (EXTMODE=Hi) 2

[Note 6-6-2]

Inversion at EXTCOMIN rising edge.

- ※1 : COM inversion polarity has been set by rising edge of EXTCOMIN.
- ※2 : The period of EXTCOMIN should be constant.
- ※3 : COM Flag-bit and COM inversion on the rising edge of EXTCOMIN.

Table 6-6-3 COM state 3 (EXTMODE=Hi and SCS=Lo)

		COM state (COM flag state) [note 6-6-2]		
		EXTCOMIN	State before inversion	Status after inversion
SCS=Lo	Hi		1	0
	Lo		0	1

6.7 Mode Change Sequence

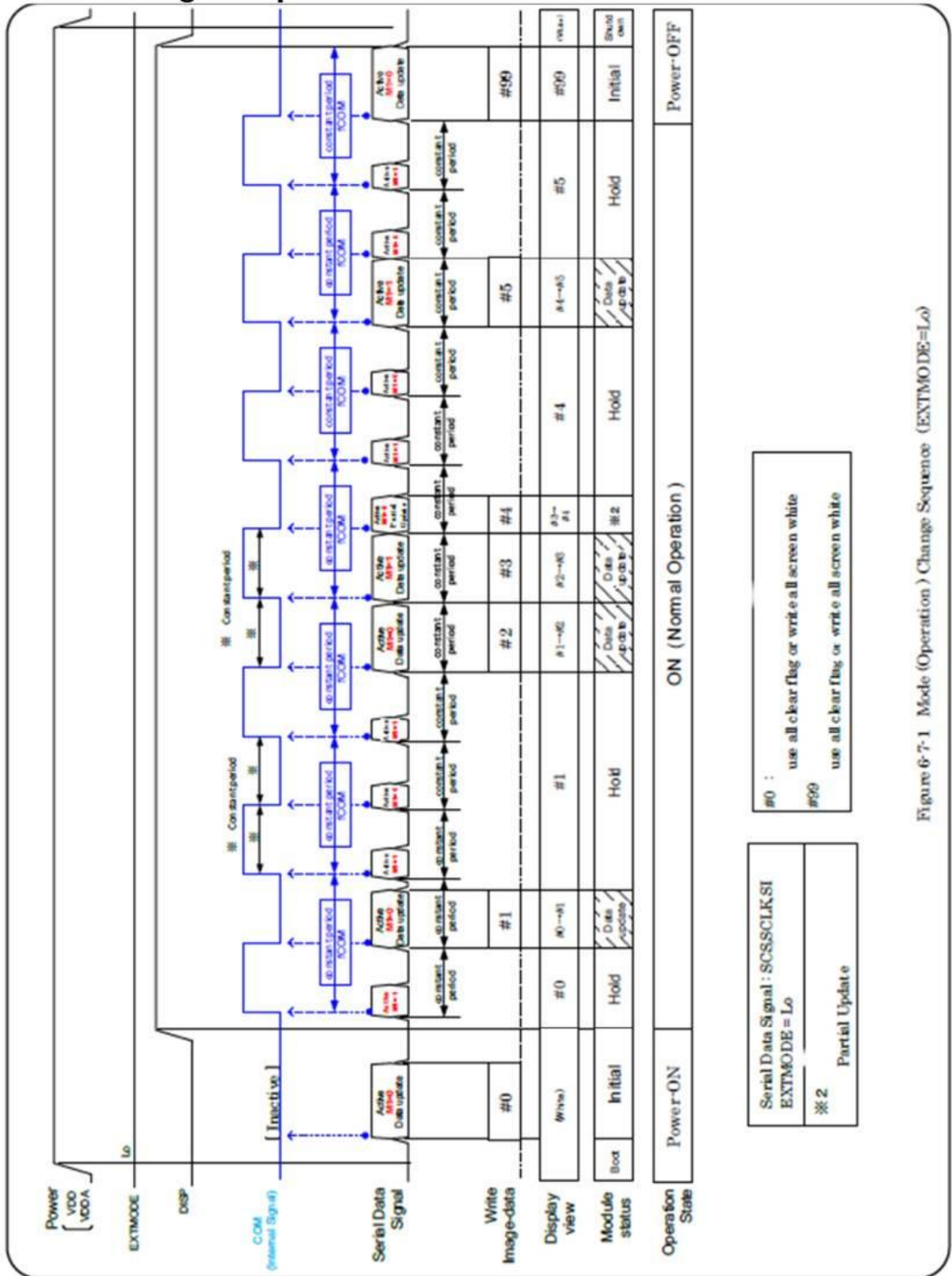

#0 : use all clear flag or write all screen white
 #59 : use all clear flag or write all screen white

Serial Data Signal : SCSSCLKSI
 EXTMODE = Lo
 ※2 : Partial Update

Figure 6-7-1 Mode (Operation) Change Sequence (EXTMODE=Lo)

6.8 Input Signal and Display, Gate Address (Line), Settings

Table 6-8-1

Gate line address setting

GL: Gate address line

GL	AG0	AG1	AG2	AG3	AG4	AG5	AG6
1	1	0	0	0	0	0	0
2	0	1	0	0	0	0	0
3	1	1	0	0	0	0	0
4	0	0	1	0	0	0	0
5	1	0	1	0	0	0	0
6	0	1	1	0	0	0	0
7	1	1	1	0	0	0	0
8	0	0	0	1	0	0	0
9	1	0	0	1	0	0	0
10	0	1	0	1	0	0	0
11	1	1	0	1	0	0	0
12	0	0	1	1	0	0	0
13	1	0	1	1	0	0	0
14	0	1	1	1	0	0	0
15	1	1	1	1	0	0	0
16	0	0	0	0	1	0	0
17	1	0	0	0	1	0	0
18	0	1	0	0	1	0	0
19	1	1	0	0	1	0	0
20	0	0	1	0	1	0	0
21	1	0	1	0	1	0	0
22	0	1	1	0	1	0	0

GL	AG0	AG1	AG2	AG3	AG4	AG5	AG6
23	1	1	1	0	1	0	0
24	0	0	0	1	1	0	0
25	1	0	0	1	1	0	0
26	0	1	0	1	1	0	0
27	1	1	0	1	1	0	0
28	0	0	1	1	1	0	0
29	1	0	1	1	1	0	0
30	0	1	1	1	1	0	0
31	1	1	1	1	1	0	0
32	0	0	0	0	0	1	0
33	1	0	0	0	0	1	0
34	0	1	0	0	0	1	0
35	1	1	0	0	0	1	0
36	0	0	1	0	0	1	0
37	1	0	1	0	0	1	0
38	0	1	1	0	0	1	0
39	1	1	1	0	0	1	0
40	0	0	0	1	0	1	0
41	1	0	0	1	0	1	0
42	0	1	0	1	0	1	0
43	1	1	0	1	0	1	0
44	0	0	1	1	0	1	0

GL	AG0	AG1	AG2	AG3	AG4	AG5	AG6
45	1	0	1	1	0	1	0
46	0	1	1	1	0	1	0
47	1	1	1	1	0	1	0
48	0	0	0	0	1	1	0
49	1	0	0	0	1	1	0
50	0	1	0	0	1	1	0
51	1	1	0	0	1	1	0
52	0	0	1	0	1	1	0
53	1	0	1	0	1	1	0
54	0	1	1	0	1	1	0
55	1	1	1	0	1	1	0
56	0	0	0	1	1	1	0
57	1	0	0	1	1	1	0
58	0	1	0	1	1	1	0
59	1	1	0	1	1	1	0
60	0	0	1	1	1	1	0
61	1	0	1	1	1	1	0
62	0	1	1	1	1	1	0
63	1	1	1	1	1	1	0
64	0	0	0	0	0	0	1
65	1	0	0	0	0	0	1
66	0	1	0	0	0	0	1
67	1	1	0	0	0	0	1
68	0	0	1	0	0	0	1

Data position in display [H , V]

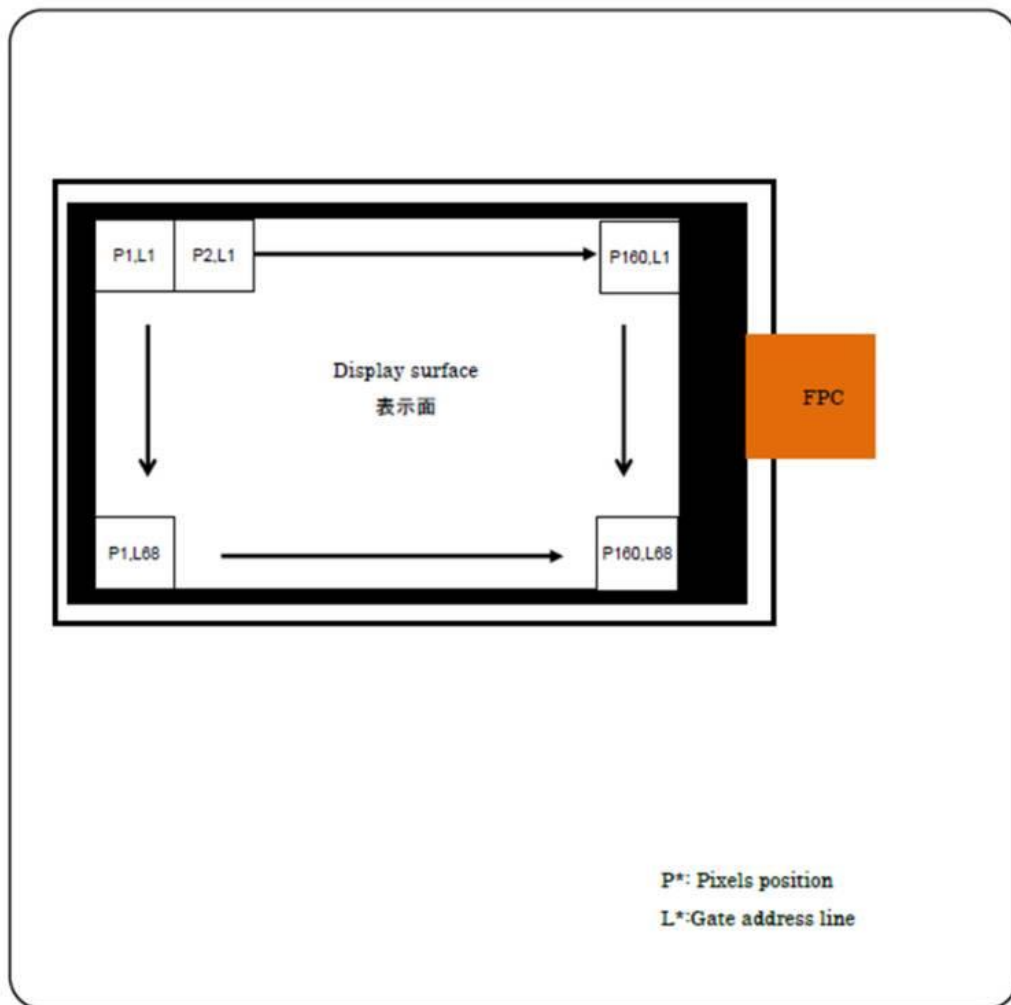

Figure 6-8-1 Data position

7 Optical Specification

7.1 Optical Specification (Reflective Mode)

Table 7-1

Optical specification (Reflective Mode)

VDD = VDDA = +3.0V , Ta = 25°C

Item	Symbol	Min.	Typ.	Max.	unit	Remark	
Viewing angle Range CR ≥ 2	Horizontal	$\theta 21$	40	60	-	°(degree) Note 7-1	
		$\theta 22$	40	60	-		
	Vertical	$\theta 11$	40	60	-		
		$\theta 12$	40	60	-		
Contrast ratio	CR	15	20	-		Note 7-2 Note 7-3	
Reflectivity ratio	R	12	16.5	-	%	Note 7-3	
Response Time	Rise	τr	-	10	-	ms	Note 7-3
	Fall	τd	-	20	-	ms	Note 7-4
Panel Chromaticity	White	x	-	0.31	-		Note 7-3
		y	-	0.33	-		

[Note 7-1]

Defintion of Viewing Angle

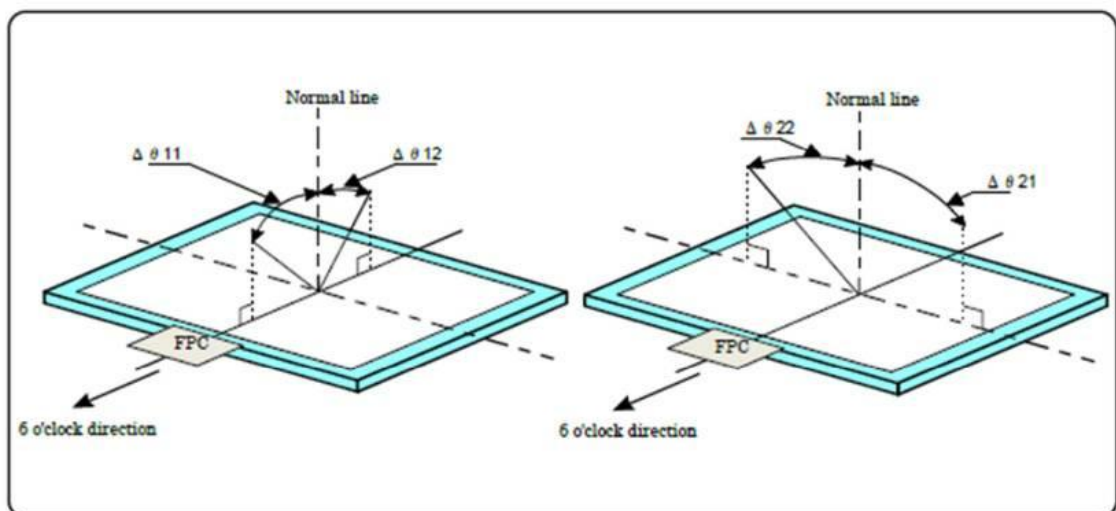

Figure 7-1 Defintion of Viewing Angle

7.2 Optical Specification Transmissive Mode

Table 7-2 Optical specification (Transmissive Mode)

VDD = VDDA = +3.0V , Ta = 25°C

Item	Symbol	Min.	Typ.	Max.	unit	Remark
Transmissivity ratio	T	—	0.25	—	%	Note 7-6

[Note 7-2]

Defintion of Contrast Ratio

•The contrast ratio is defined as the following.

$$\text{Contrast ratio(CR)} = \frac{\text{Reflection intensity in white display}}{\text{Reflection intensity in black display}}$$

[Note 7-3]

Optical characteristics measurement equipment.

• Figure 7-2 is for contrast ratio, reflectivity ratio, and panel chromaticity measurement, and Figure 7-3 is for response time measurement. Both are to be conducted in a dark or room equipment to a dark room

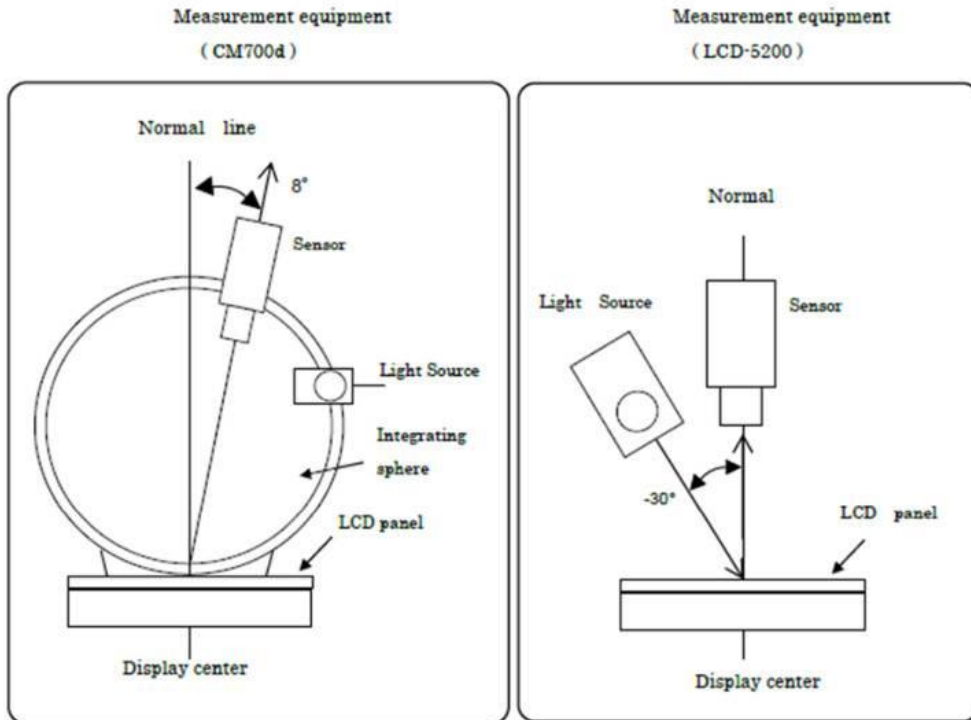

Figure 7-2 Contrast ratio, Reflection ratio,

Figure 7-3 Response time

[Note 7-4]

Response time (Change in reflection ratio)

It's defined by the time change of optical receiver output when signal is input to display white or black

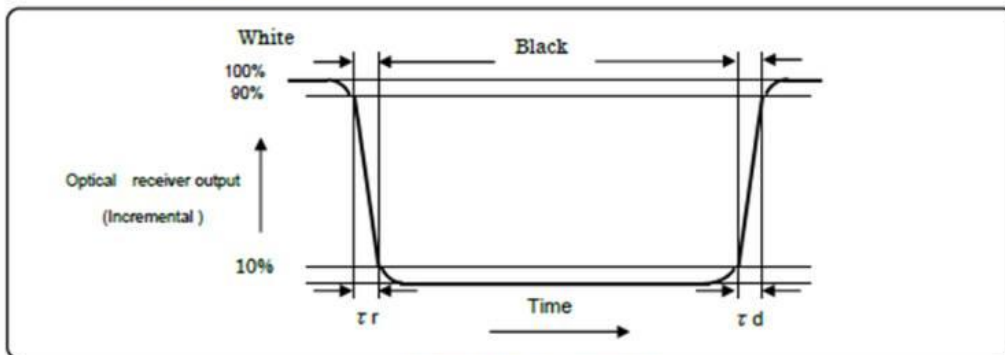

Figure 7-4 Response time

[Note 7-5]

Measurement equipment (Transmissive mode)

The measuring method of the optical characteristics (Transmissive mode) is shown by the following figure. A measurement device is TOPCON luminance meter SR-3 UL1R.

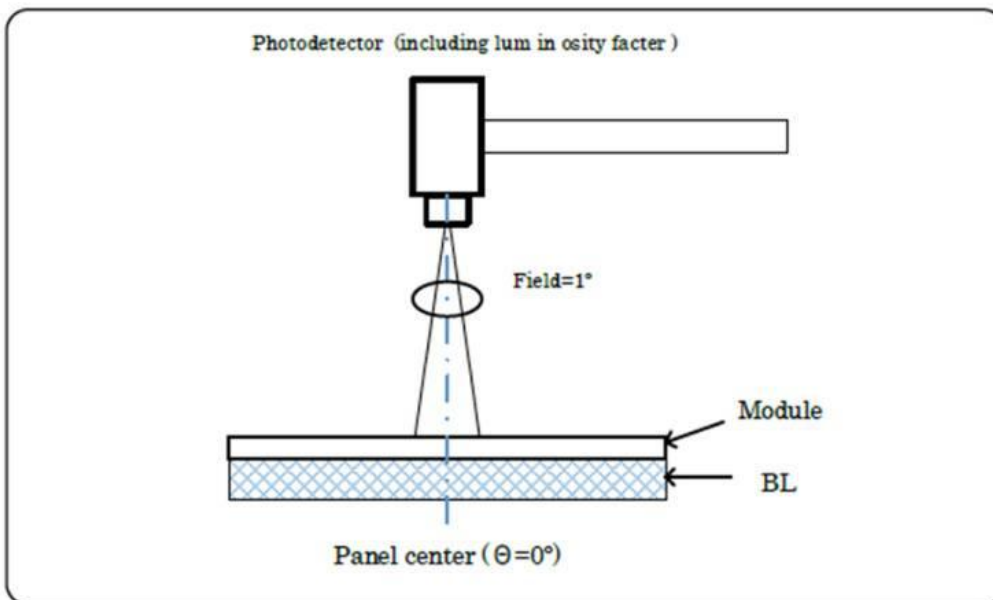
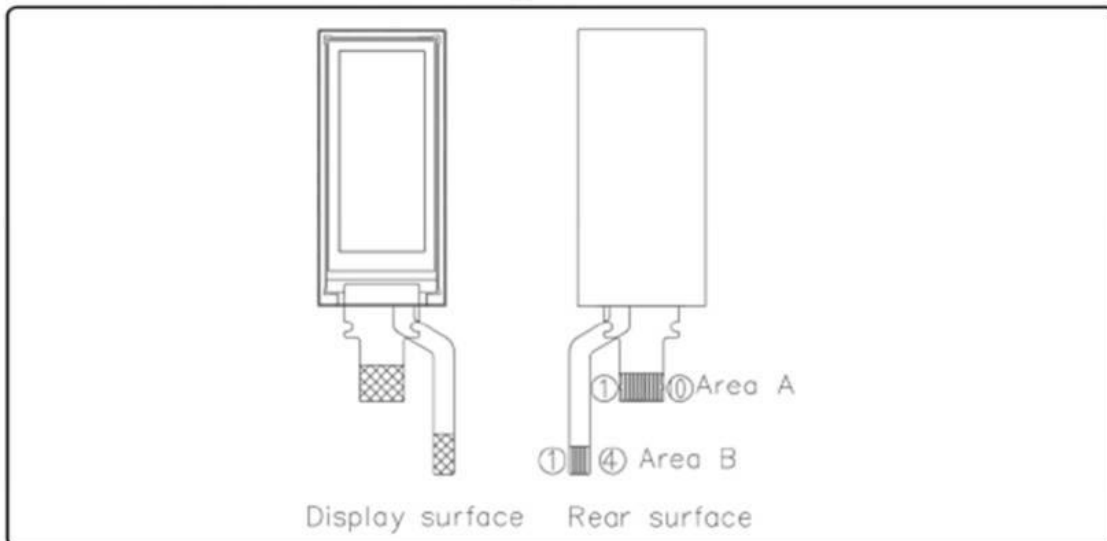

Figure 7-5 Measuring setup for Luminance

8 Pin Assignment

8.1 Pin Assignment

The outline dimensions are shown in Figure 14-1



NO	Symbol
1	SCLK
2	SI
3	SCS
4	EXTCOMIN
5	DSIP
6	VDDA
7	VDD
8	EXTMODE
9	VSS
10	VSSA

Table 8-1-1 TFT LCD panel terminal

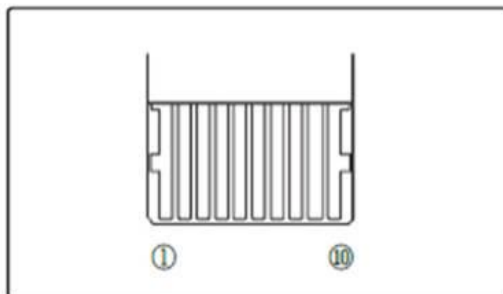

Figure 8-1-1 Pin Assignment 1 (Area A)

8.2 FPC Bending Specification

8-2) FPC

FPC Bend Specification

Table 8-2-1 Recommended Connector

Product manufacturer	Series	Part number	Contact
Panasonic	Y5B	AYF531035	Bottom and Upper
HRS	FH34SRJ	FH34SRJ-10S-0.5SH	Bottom and Upper
	FH28	FH28-10S-0.5SH	Bottom
Molex	503480	503480-1000	Bottom and Upper

When bending FPC, bend where specified in Condition (1) and the bend R should be more than R specified in Condition (2). FPC is not to contact glass edge, and there should be no stress to connective area between panel and FPC.

Condition (1) FPC bend recommended area: 0.8 mm – 6.0 mm from glass edge.

Condition (2) Minimum bend R: Inner diameter R 0.45 mm



Figure 8-2-1 FPC Bend Specification

[Note 8-2-1]

Do not bend to the front polarizer film side.

[Note 8-2-2]

Bend frequency: 3 times or less (Repeat bend condition: 180°~ 0°)

[Note 8-2-3]

Do not hang LCD module by FPC or apply force to FPC.

9 Display Qualities and Warranty Period

Please refer to the incoming inspection standard (IIS).
The warranty period is 12 months from the month of shipment. If there is an individual contract, it will be discussed separately.

10 External Capacitors

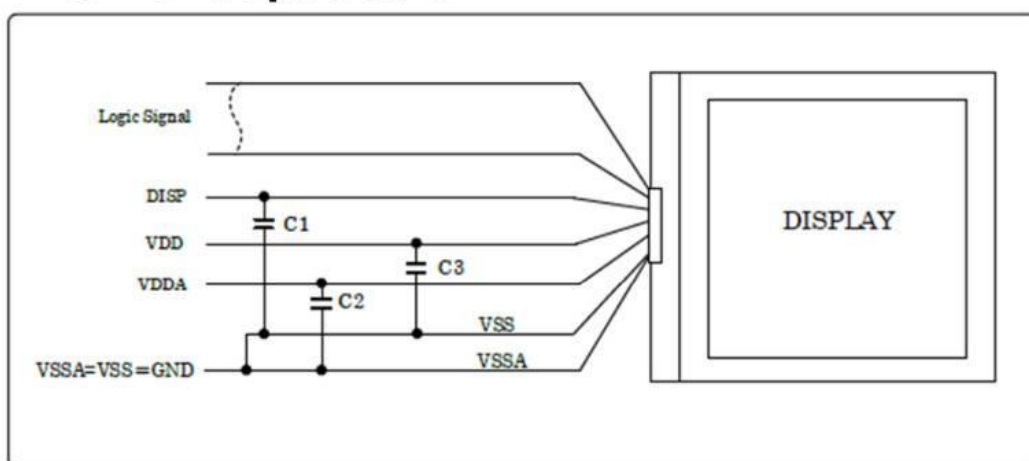

Figure 10-1 External capacitor recommendation capacity value

Recommended capacity value

C1 : DISP - VSS : rank B 560pF Ceramic capacitor

The recommended minimum capacitance value on DISP is 560pF.
However, it should be adjusted to ensure that the DISP rise time limit is not exceeded.

C2 : VDDA - VSSA : rank B 1.0uF Ceramic capacitor

C3 : VDD - VSS : rank B 1.0uF Ceramic capacitor

Above circuit and parts are only recommendation.
For actual use, please evaluate their conformity with your system and design.
(Capacitor value can be larger than value indicated above.)

11 Reliability Test Conditions

Table13-1-1 Reliability Test Items

No.	Test Item	Condition	Remark
1	Non operating test	High temperature storage test Ta= + 80℃	240 h Note 13-1-1
2		Low temperature storage test Ta= -30℃ (No condensation)	240 h Note 13-1-1
3		Thermal Shock test Ta= -30℃ (1 h) ~ +80 ℃ (1 h)	5 cycle Note 13-1-1
4		Electro static discharge test ±200 V、200 pF (0Ω) 1回 each terminal : 1 time	Note 13-1-1
5	High temperature and high humidity operating test	Tp= 40℃ / 95%RH (No condensation)	240 h Note 13-1-1
6	High temperature operating test	Tp= + 70 ℃	240 h Note 13-1-1
7	Low temperature operating test	Tp= -20℃ (No condensation)	240 h Note 13-1-1

[Note 13-1-1]

Ta = Ambient temperature
Tp = Panel surface temperature

Result Evaluation Criteria

Under the display quality test conditions with normal operation state, these shall be no change which may affect practical display function.

(※)

normal operation state:

Temperature : +15 ~ +35℃
Humidity : 45 ~ 75%,
Atmospheric pressure : 86 ~ 106 kpa

12 Outline Dimensions

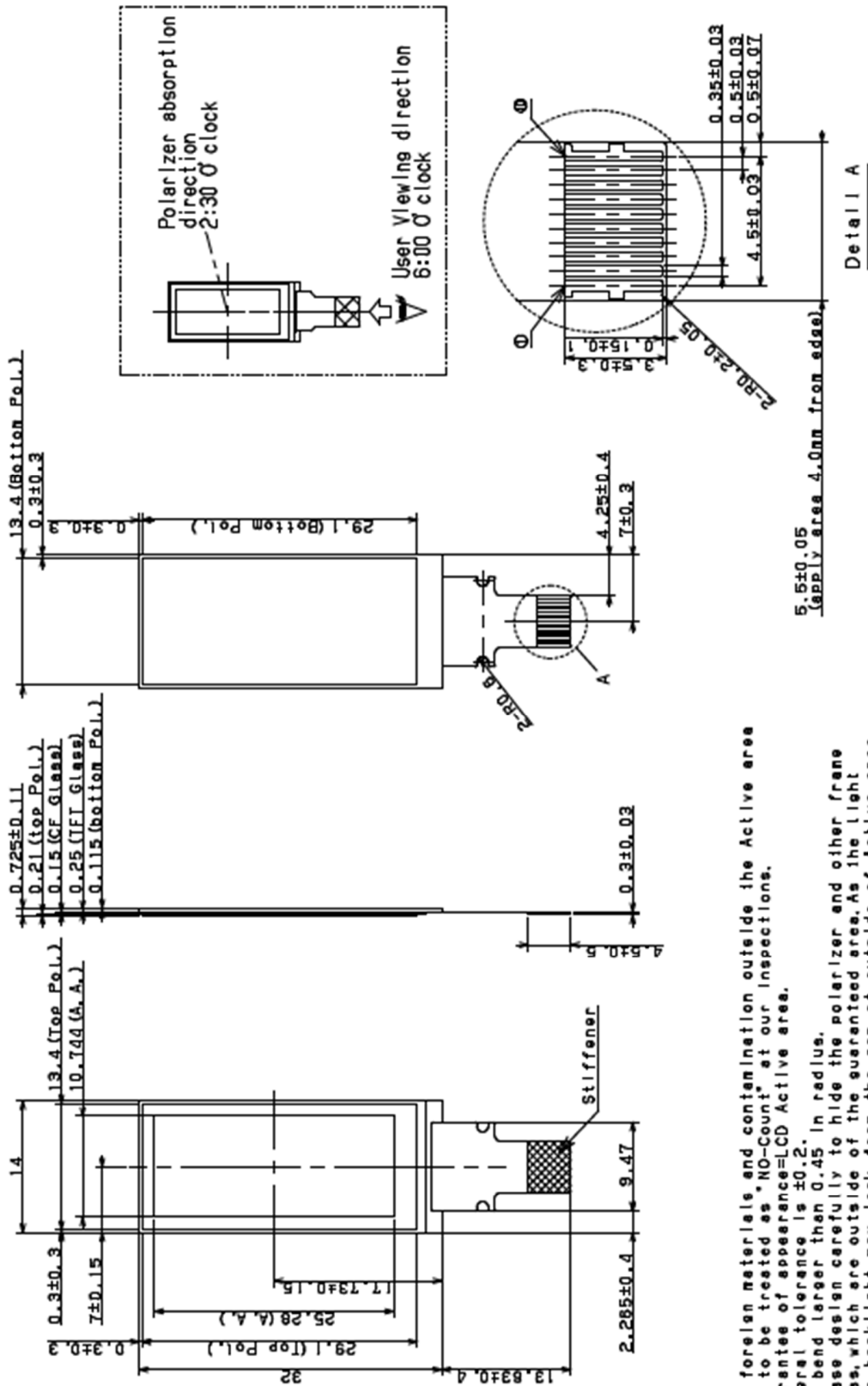

Unit: mm

Figure 14-1 Outline dimensions

Any foreign materials and contamination outside the Active area are to be treated as "NO-Count" at our inspections. Guarantee of appearance=LCD Active area. General tolerance is ±0.2. FPC bend larger than 0.45 in radius. Please design carefully to hide the polarizer and other frame areas, which are outside of the guaranteed area. As the light from backlight may leak from the gap at outside of Active area, which are outside of active area, please pay attentions to such leakage when designing the set. The tolerances of the module width do not include warps of the glass.