

Display Elektronik GmbH

DATA SHEET

TFT MODULE

DEM 800480Y VMH-PW-N

(A-TOUCH)

5,0“ TFT

(IPS)

Product Specification

Ver.: 0

03.02.2020

Revise Records

Rev.	Date	Contents	Written	Approved
0	03.02.2020	Preliminary Specification	A	MHI

Special Notes

Note1.	

Contents

1	General Description and Features	4
1.1	Features	4
1.2	LCD Module	4
2	Mechanical Information	5
3	Electrical Specifications	5
3.1	Absolute Max. Ratings	5
3.2	Electrical Absolute Rating	5
4	Electrical Characteristics	6
4.1	TFT-LCD Module	6
4.2	Backlight Unit	6
5	Touch Screen Panel Specifications	7
5.2	Mechanical & Reliability Characteristics.....	7
6	Block Diagram	8
7	Input Terminal Pin Assignment	9
7.1	CN1 Pin Assignment	9
8	Optical Characteristics	10
9	Basic Display Color and Gray Scale	12
10	Timing Characteristics	13
10.1	Power ON/OFF Sequence	13
10.2	AC Timing Characteristics	14
10.3	Display Timing Characteristics (Resolution 800*480)	15
11	Test	16
12	Dimensional Outlines	17
13	Incoming Inspection Standards	18

1 General Description and Features

DEM 800480Y VMH-PW-N(A-TOUCH) is a Normally black TFT (Thin Film Transistor) liquid crystal display (LCD) that uses amorphous silicon TFT as a switching device. This model is composed of a TFT-LCD module, a driver circuit and a back-light unit. The resolution of a 5.0" contains 800(RGB)x480 dots and can display up to 16.7M colors. The following table described the features of DEM 800480Y VMH-PW-N(A-TOUCH).

1.1 Features

- Transmissive and back-light with 24 LEDs are available.
- IPS
- 24bit RGB Interface
- ROHS Compliance

1.2 LCD Module

Item	Specification	Unit
Screen Size	5.0 Inches	Diagonal
Display Resolution	800 x RGB x 480	Dot
Dot Pitch	0.135 x 0.135	mm
Active Area	108.00 x 64.80	mm
Outline Dimension	118.50 x 77.55 x 4.50	mm
Display Mode	Normally Black	--
Pixel Arrangement	RGB Vertical-Stripe	--
Surface Treatment	Anti-Glare (AG)	--
Display Color	16.7 Million	--
Viewing Direction	FREE	--
Input Interface	Digital 24-Bits Parallel RGB	--

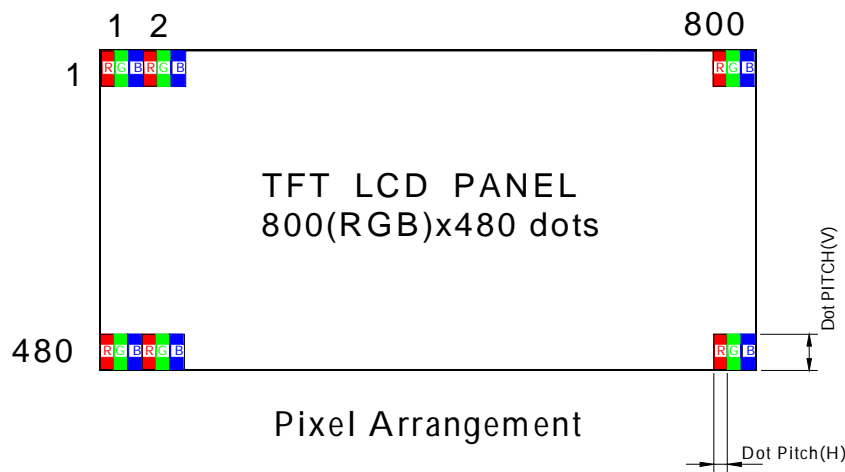

2 Mechanical Information

Item		Min.	Typ.	Max.	Unit	Note
Module Size	Horizontal (H)	--	118.50	--	mm	--
	Vertical (V)	--	77.55	--	mm	(1)
	Thickness (T)	--	4.50	--	mm	(1)
Weight		--	-	--	g	--

Note (1) Not include FPC.

Refer to the Dimensional Outlines for further information.

3 Electrical Specifications

3.1 Absolute Max. Ratings

3.1.1 Absolute Ratings of Environment

If the operating condition exceeds the following absolute maximum ratings, the TFT LCD module may be damaged permanently.

(Ta=25±2°C, Vss=GND=0)

Item	Symbol	Min.	Max.	Unit	Note
Storage Temperature	T _{STG}	-30	80	°C	(1)
Operating Temperature	T _{OPR}	-20	70	°C	(1,2,3)

Note (1) 95 % RH Max. (40 °C ≥ Ta). Maximum wet-bulb temperature at 39 °C or less. (Ta > 40 °C) No condensation.

Note (2) In case of below 0°, the response time of liquid crystal (LC) becomes slower and the color of panel becomes darker than normal one. Level of retardation depends on temperature, because of LC's character

Note (3) Only operation is guaranteed at operating temperature. Contrast, response time, another display quality are evaluated at +25°C.

3.2 Electrical Absolute Rating

3.2.1 TFT-LCD Module

(Ta=25±2°C, Vss=GND=0)

Item	Symbol	Value		Unit	Condition
		Min.	Max.		
Power Supply Voltage	V _{DD}	-0.3	4.5	V	

3.2.2 Back-Light Unit

(Ta=25±2°C)

Item	Symbol	Min.	Max.	Unit	Note
Current of One LED	I _{LED}	--	(25)	mA	(1)

Note (1) Permanent damage to the device may occur if maximum values are exceeded or reverse voltage is loaded. Functional operation should be restricted to the conditions described under normal operating conditions.

4 Electrical Characteristics

4.1 TFT-LCD Module

(Ta=25±2°C, VDD =3.3V)

Item	Symbol	Value			Unit	Condition
		Min.	Typ.	Max.		
Power Supply Voltage	V _{DD}	3.0	3.3	3.6	V	
Input Voltage for Logic	H Level	0.7xV _{DD}	-	V _{DD}	V	
	L Level	0	-	0.3xV _{DD}	V	
Digital Current	I _{DD}	-	80	120	mA	

Note (1) The specified power consumption is under the conditions at V_{CC}=3.3V , F_v=60Hz, whereas a Power dissipation check pattern below is displayed.

White Pattern



Active Area

4.2 Backlight Unit

The back-light system is an edge-lighting type with white LED (Light Emitting Diode)s.

(Ta=25±2°C)

Item	Symbol	Value			Unit	Condition
		Min.	Typ.	Max.		
LED Voltage	V _L	12	13.2	14	V	
LED Current	I _f	-	120	-	mA	
Power Consumption	P _{BL}	-	1584	-	mW	(2)
LED Lifetime (25°C)	-	30000	50000	-	hr	(3)

Note : (1) 4 LEDs serial 6 parallel type.

(2) Where I_f = 120mA, V_L = 13.2 V, P_{BL} = V_L × I_f

(3)The environmental conducted under ambient air flow ,at Ta=25±2°C,60%RH±5%

5 Touch Screen Panel Specifications**5.1 Electrical Characteristics**

Item	Min.	Typ.	Max.	Unit	Note
Linearity	-1.5	-	1.5	%	Analog X and Y directions
Terminal Resistance	(200)	-	(1000)	Ω	X
	(200)	-	(900)	Ω	Y
Insulation Resistance	20	-	-	M Ω	DC 25V
Voltage	-	5.0	-	V	DC
Chattering	-	-	10	ms	100k Ω pull-up

5.2 Mechanical & Reliability Characteristics

Item	Min.	Typ.	Max.	Unit	Note
Activation Force	60	-	100	g	(1)
Hitting Durability	1,000,000	-	-	times	(2)
Sliding Durability	100,000	-	-	times	(3)
Surface Hardness	3	-	-	H	JIS K5400

Note (1) Input : Finger or polyacetal pen 0.8R

Note (2) Pit 1,000,000 times on the Film with a R8.0 (Hardness 60°) silicon rubber.

- Force : 250g
- Frequency : 2 times/sec

Note (3) Touch panel is drawn by R0.8 Derlin stylus pen, repeat 10mm~100mm by 100,000 times.

- Force : 250g
- Frequency : 60mm/sec

6 Block Diagram

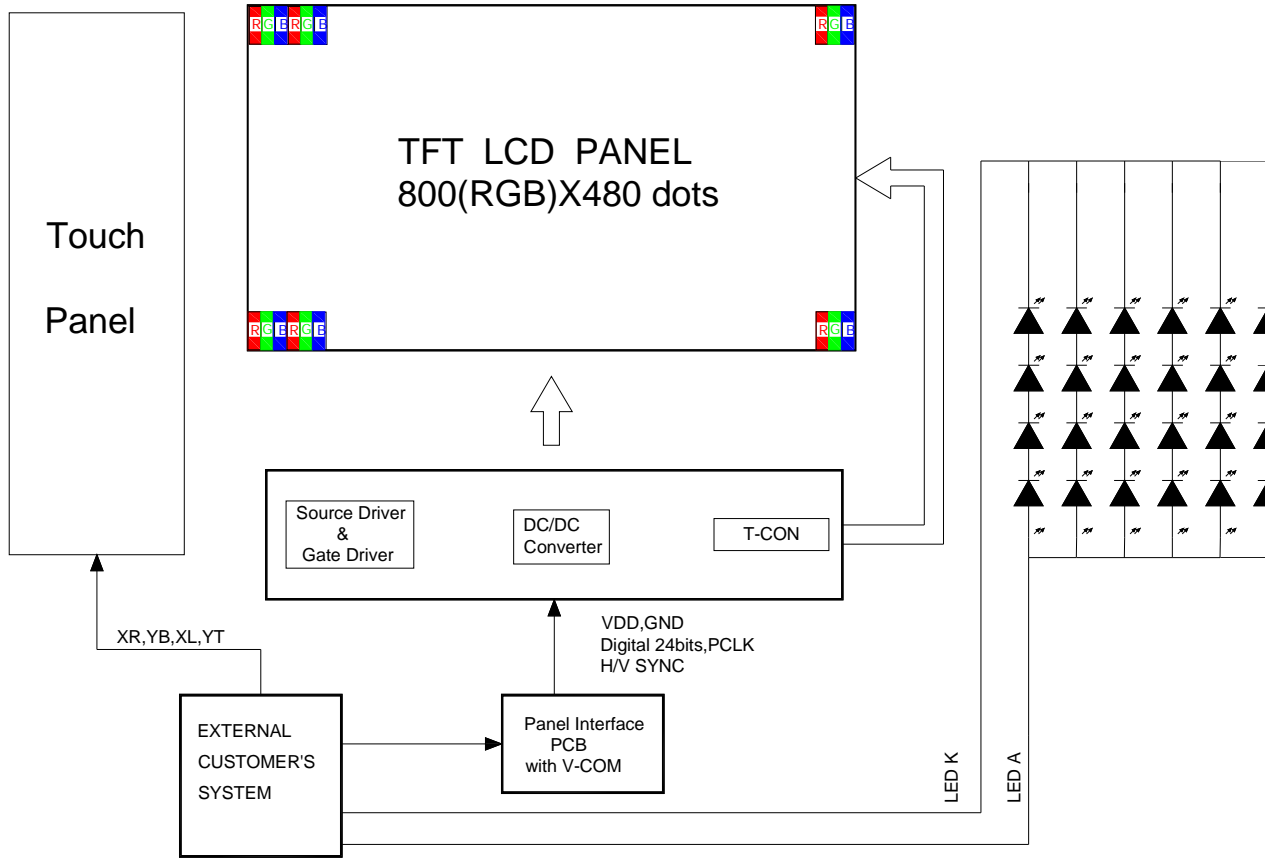

7 Input Terminal Pin Assignment**7.1 CN1 Pin Assignment**

(Reference Connector: Hirose Electric Co., LTD. Product No. FH12A-40S-0.5SH(55) Top contact type)

Pin No.	Symbol	I/O	Function	Remark
1	LEDK	P	Backlight Cathode	
2	LEDA	P	Backlight Anode	
3	VSS	P	Ground	
4	V _{DD}	P	Logic power supply(+3.0~3.6V)	
5	R0	I	Red Data Bit 0(LSB)	
6	R1	I	Red Data Bit 1	
7	R2	I	Red Data Bit 2	
8	R3	I	Red Data Bit 3	
9	R4	I	Red Data Bit 4	
10	R5	I	Red Data Bit 5	
11	R6	I	Red Data Bit 6	
12	R7	I	Red Data Bit 7(MSB)	
13	G0	I	Green Data Bit 0(LSB)	
14	G1	I	Green Data Bit 1	
15	G2	I	Green Data Bit 2	
16	G3	I	Green Data Bit 3	
17	G4	I	Green Data Bit 4	
18	G5	I	Green Data Bit 5	
19	G6	I	Green Data Bit 6	
20	G7	I	Green Data Bit 7(MSB)	
21	B0	I	Blue Data Bit 0 (LSB)	
22	B1	I	Blue Data Bit 1	
23	B2	I	Blue Data Bit 2	
24	B3	I	Blue Data Bit 3	
25	B4	I	Blue Data Bit 4	
26	B5	I	Blue Data Bit 5	
27	B6	I	Blue Data Bit 6	
28	B7	I	Blue Data Bit 7(MSB)	
29	VSS	P	Ground	
30	P _{CLK}	I	Dot Data Clock	
31	DISP	I	Display on/off	
32	H _{SYNC}	I	Horizontal Sync Input	
33	V _{SYNC}	I	Vertical Sync Input	
34	DE	I	Data Enable	
35	NC	-	No Connect	
36	VSS	P	Ground	
37	XR	O	Touch Panel Right Side	
38	YB	O	Touch Panel Bottom Side	

39	XL	O	Touch Panel Left Side	
40	YT	O	Touch Panel Top Side	

8 Optical Characteristics

The following items are measured under stable conditions. The optical characteristics should be measured in a dark room

Measuring equipment: BM-7A

(Ta=25±2°C , VDD =3.3V, If=40mA)

Item	Symbol	Condition	Min.	Typ.	Max.	Unit	Note
Brightness	--	--	650	800	--	cd/m ²	--
Response Time	T _R	θ=0°	--	30	--	ms	--
	T _F		--	30	--	ms	
Contrast Ratio	CR	At optimized viewing angle	600	800	--	--	--
Color Chromaticity	Red	R _X	0.55	0.60	0.65	--	--
		R _Y	0.30	0.35	0.40		
	Green	G _X	0.31	0.36	0.41	--	
		G _Y	0.52	0.57	0.62		
	Blue	B _X	0.08	0.13	0.18	--	
		B _Y	0.09	0.14	0.19		
	White	W _X	0.30	0.35	0.40	--	
		W _Y	0.33	0.38	0.43		
Viewing Angle (6H)	Hor.	θ _R	--	80	--	Degree	--
		θ _L	--	80	--		
	Ver.	θ _U	--	80	--		
		θ _D	--	80	--		

a. Test equipment setup

After stabilizing and leaving the panel alone shall be warmed up for the stable operation of LCM, the measurement should be executed. Measurement should be executed in a stable, windless, and dark room. Optical specifications are measured by Topcon BM-5A/BM-7(fast) with a viewing angle of 2° at a distance of 50cm and normal direction.

b. Definition of response time: Tr and Tf

The response time is defined as the following figure and shall be measured by switching the input signal for "black" and "white".

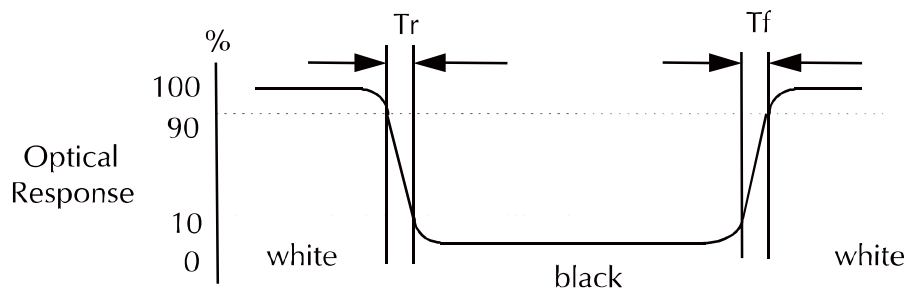

c. Definition of contrast ratio:

$$\text{Contrast Ratio (CR)} = \frac{\text{Brightness measured when LCD is at "white state"}}{\text{Brightness measured when LCD is at "black state"}}$$

d. Measured at the center area of the panel when all the input terminals of LCD panel are electrically opened.

e. View Angle

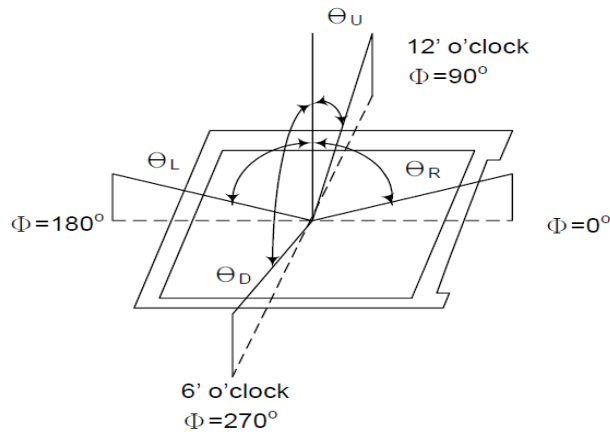

f. Definition of Luminance of White: Luminance of white at the center points

Light Source of Back-Light Unit	LED Type
---------------------------------	----------

g. Definition of White Uniformity

$$\text{White Uniformity} = \frac{\text{Min. luminance of white among 9-points}}{\text{Max. luminance of white among 9-points}} \times 100\%$$

h. The definition of Color Gamut -Color Chromaticity CIE 1931

Color coordinate of white & red, green, blue at center point.

$$\text{Color Gamut : NTSC(\%)} = \left(\frac{\text{RGB Triangle Area}}{\text{NTSC Triangle Area}} \right) \times 100$$

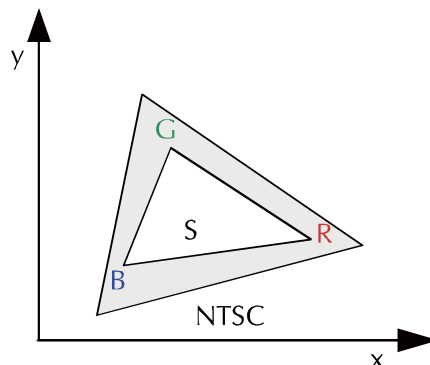

9 Basic Display Color and Gray Scale

	Color & Gray Scale	Data Signal																							
		R7	R6	R5	R4	R3	R2	R1	R0	G7	G6	G5	G4	G3	G2	G1	G0	B7	B6	B5	B4	B3	B2	B1	B0
Basic Color	Black	0	0	0	0	0	0	0	0	0	0	0	0	0	0	0	0	0	0	0	0	0	0	0	
	Red	1	1	1	1	1	1	1	1	0	0	0	0	0	0	0	0	0	0	0	0	0	0	0	
	Green	0	0	0	0	0	0	0	0	1	1	1	1	1	1	1	1	0	0	0	0	0	0	0	
	Blue	0	0	0	0	0	0	0	0	0	0	0	0	0	0	0	0	1	1	1	1	1	1	1	
	Cyan	0	0	0	0	0	0	0	0	1	1	1	1	1	1	1	1	1	1	1	1	1	1	1	
	Magenta	1	1	1	1	1	1	1	1	0	0	0	0	0	0	0	0	1	1	1	1	1	1	1	
	Yellow	1	1	1	1	1	1	1	1	1	1	1	1	1	1	1	1	0	0	0	0	0	0	0	
	White	1	1	1	1	1	1	1	1	1	1	1	1	1	1	1	1	1	1	1	1	1	1	1	
Red	Black	0	0	0	0	0	0	0	0	0	0	0	0	0	0	0	0	0	0	0	0	0	0		
	Red(1)	0	0	0	0	0	0	0	1	0	0	0	0	0	0	0	0	0	0	0	0	0	0		
	Red(2)	0	0	0	0	0	0	1	0	0	0	0	0	0	0	0	0	0	0	0	0	0	0		
	:	:	:	:	:	:	:	:	:	:	:	:	:	:	:	:	:	:	:	:	:	:	:		
	Red(127)	0	1	1	1	1	1	1	1	0	0	0	0	0	0	0	0	0	0	0	0	0	0		
	:	:	:	:	:	:	:	:	:	:	:	:	:	:	:	:	:	:	:	:	:	:	:		
	Red(254)	1	1	1	1	1	1	1	0	0	0	0	0	0	0	0	0	0	0	0	0	0	0		
Red(255)	1	1	1	1	1	1	1	1	0	0	0	0	0	0	0	0	0	0	0	0	0	0			
Green	Black	0	0	0	0	0	0	0	0	0	0	0	0	0	0	0	0	0	0	0	0	0	0		
	Green(1)	0	0	0	0	0	0	0	0	0	0	0	0	0	0	1	0	0	0	0	0	0	0		
	Green(2)	0	0	0	0	0	0	0	0	0	0	0	0	0	1	0	0	0	0	0	0	0	0		
	:	:	:	:	:	:	:	:	:	:	:	:	:	:	:	:	:	:	:	:	:	:	:		
	Green(127)	0	0	0	0	0	0	0	0	0	1	1	1	1	1	1	1	0	0	0	0	0	0		
	:	:	:	:	:	:	:	:	:	:	:	:	:	:	:	:	:	:	:	:	:	:	:		
	Green(254)	0	0	0	0	0	0	0	0	1	1	1	1	1	1	1	0	0	0	0	0	0	0		
Green(255)	0	0	0	0	0	0	0	0	1	1	1	1	1	1	1	1	0	0	0	0	0	0			
Blue	Black	0	0	0	0	0	0	0	0	0	0	0	0	0	0	0	0	0	0	0	0	0	0		
	Blue(1)	0	0	0	0	0	0	0	0	0	0	0	0	0	0	0	0	0	0	0	0	0	1		
	Blue(2)	0	0	0	0	0	0	0	0	0	0	0	0	0	0	0	0	0	0	0	0	0	1		
	:	:	:	:	:	:	:	:	:	:	:	:	:	:	:	:	:	:	:	:	:	:	:		
	Blue(127)	0	0	0	0	0	0	0	0	0	0	0	0	0	0	0	0	1	1	1	1	1	1		
	:	:	:	:	:	:	:	:	:	:	:	:	:	:	:	:	:	:	:	:	:	:	:		
	Blue(254)	0	0	0	0	0	0	0	0	0	0	0	0	0	0	0	0	1	1	1	1	1	1		
Blue(255)	0	0	0	0	0	0	0	0	0	0	0	0	0	0	0	0	1	1	1	1	1	1			

0 : Low level voltage, 1 :High level voltage

Each basic color can be displayed in 256 gray scales from 8 bit data signals. With the combination of total 24 bit data signals, the 16,777,216-color display can be achieved on the screen.

10 Timing Characteristics

10.1 Power ON/OFF Sequence

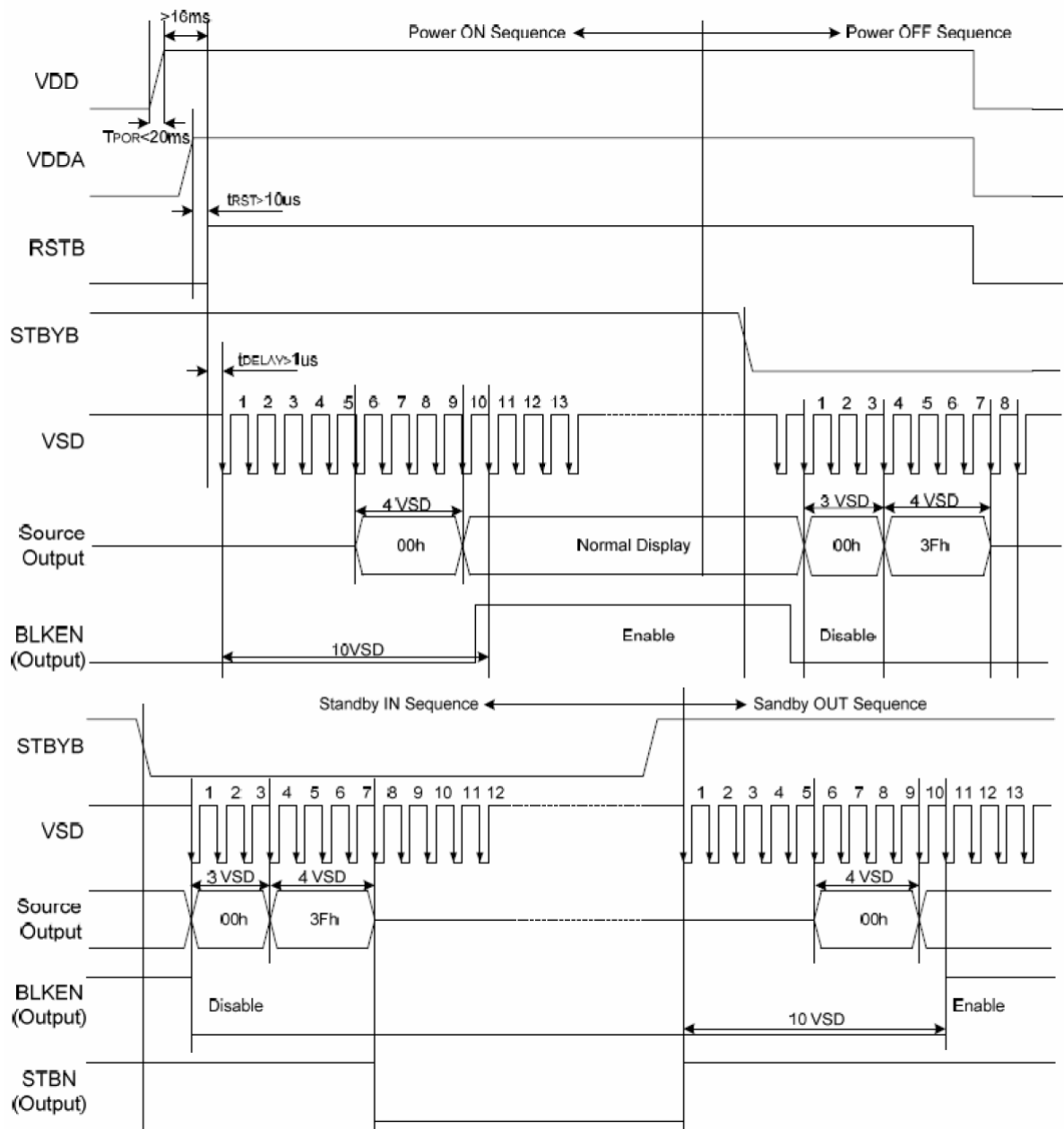

Power on sequence (VDD→VEE→VGH)

10.2 AC Timing Characteristics

DE Mode (MODE='1')

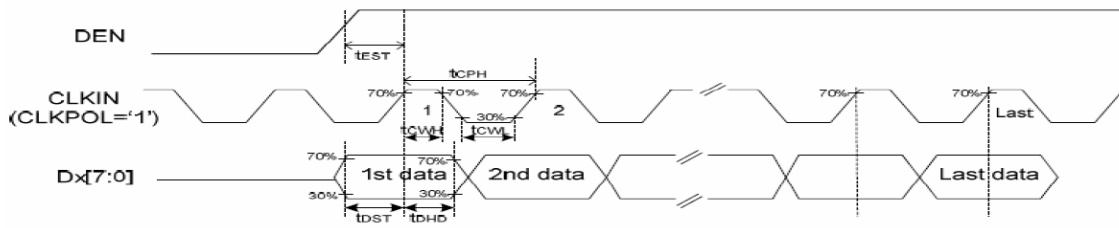

SYNC Mode (MODE='0')

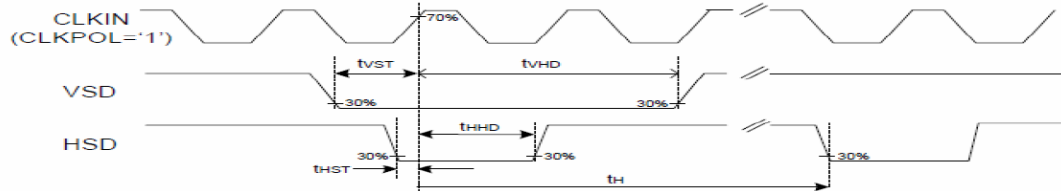

Source Output timing Diagram (Cascade)

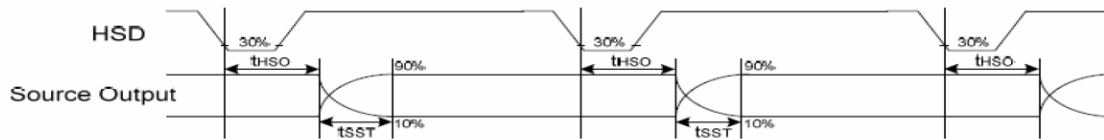

Vertical Timing Diagram of SYNC Mode (Dual Gate)

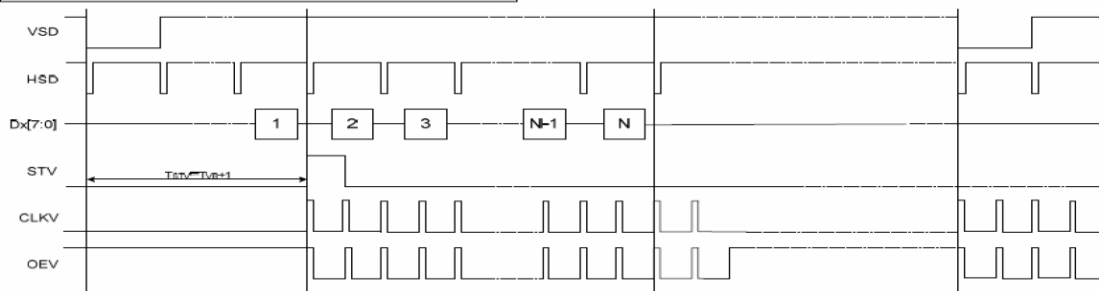

Vertical Timing Diagram of DE Mode (Dual Gate)

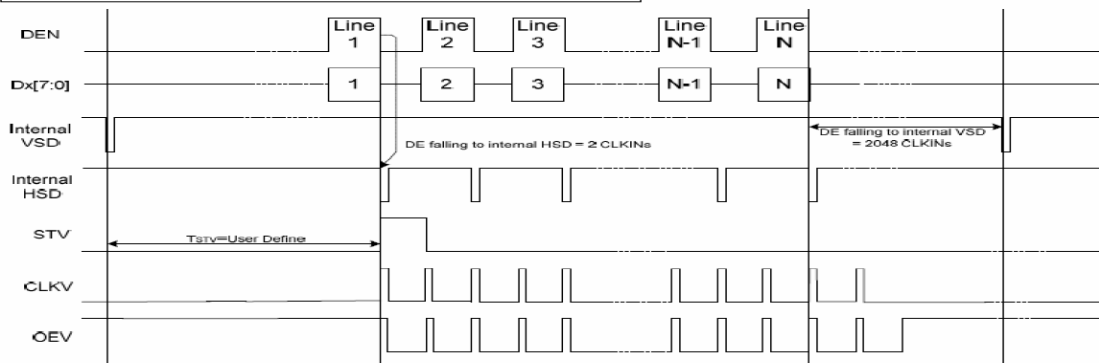

10.3 Display Timing Characteristics (Resolution 800*480)

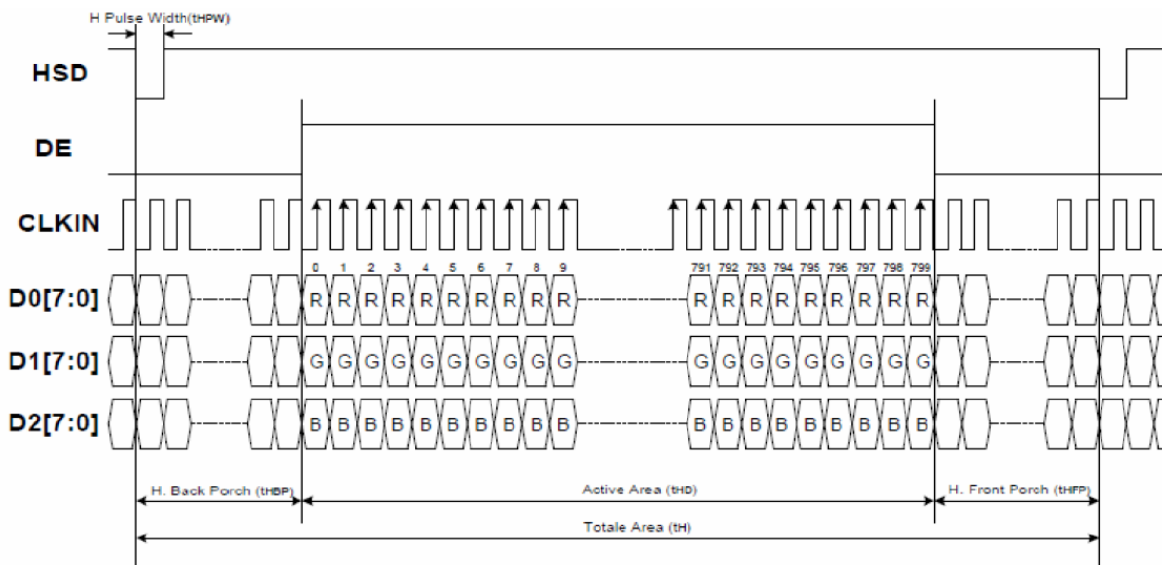

Horizontal Input Timing						
Parameter	Symbol	Value			Unit	
		Min.	Typ.	Max.		
Horizontal display area	t _{HD}	--	800	--	CLKIN	
CLKIN frequency	f _{CLK}	--	33.3	50	MHz	
1 Horizontal line period	t _H	862	1056	1200	CLKIN	
HSD pulse width	t _{HPW}	Min.	--	1	CLKIN	
		Typ.	--	--	CLKIN	
		Max.	--	40	CLKIN	
HSD back porch	SYNC	t _{HBP}	46	46	46	CLKIN
HSD front porch	SYNC	t _{HFP}	16	210	354	CLKIN

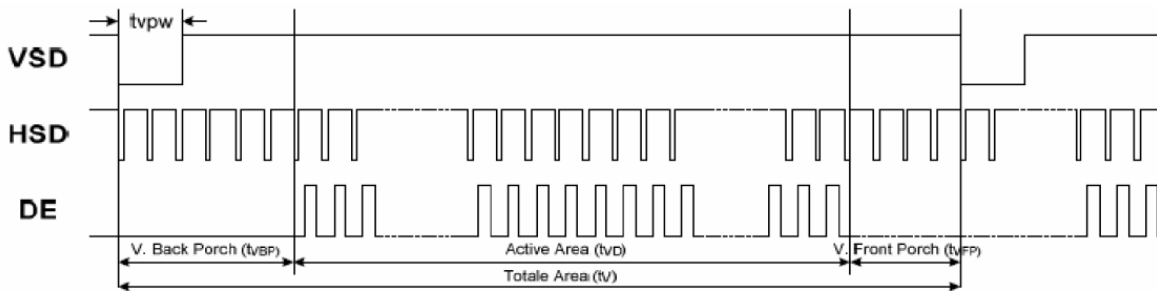

Vertical Input Timing						
Parameter	Symbol	Value			Unit	
		Min.	Typ.	Max.		
Vertical display area	t _{VD}	--	480	--	HSD	
VSD period time	t _V	510	525	650	HSD	
VSD pulse width	t _{VPW}	1	--	20	HSD	
VSD back porch	t _{VBP}	23	23	23	HSD	
VSD front porch	t _{VFP}	7	22	147	HSD	

11 Test

No change on display and in operation under the following test condition.

Condition: Unless otherwise specified, tests will be conducted under the following condition.

Temperature: 20±5°C.

Humidity: 65±5%RH.

Tests will be not conducted under functioning state.

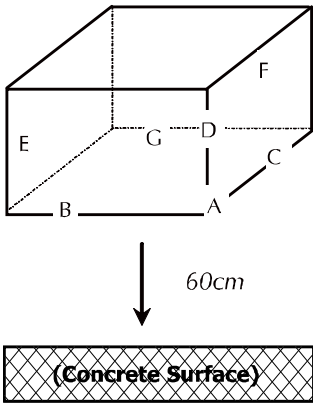
No.	Parameter	Condition	Notes
1	High Temperature Operating	70°C±2°C, 240hrs (Operation state).	
2	Low Temperature Operating	-20°C±2°C, 240hrs (Operation state).	1
3	High Temperature Storage	80°C±2°C, 240hrs.	2
4	Low Temperature Storage	-30°C±2°C, 240hrs.	1,2
5	High Temperature and High Humidity Operation Test	60°C±2°C, 90%, 240hrs	1,2
6	Vibration Test	Total fixed amplitude: 1.5mm. Vibration Frequency: 10~55Hz. One cycle 60 seconds to 3 direction of X, Y, Z each 15 minutes.	3
7	Electro Static Discharge Test (non-operating)	Panel Surface/Top Case: 150pF, 330 ohm Air: ±12kV, Contact: ±6kV	
8	Drop Test	To be measured after dropping from 60cm high on the concrete surface in packing state.  <i>Dropping method corner dropping:</i> <i>A corner: Once edge dropping.</i> <i>B, C, D edge: Once face dropping.</i> <i>E, F, G face: Once.</i>	

- Notes:
1. No dew condensation to be observed.
 2. The function test shall be conducted after 4 hours storage at the normal temperature and humidity after removed from the test chamber.
 3. Vibration test will be conducted to the product itself without putting I in a container.

12 Dimensional Outlines

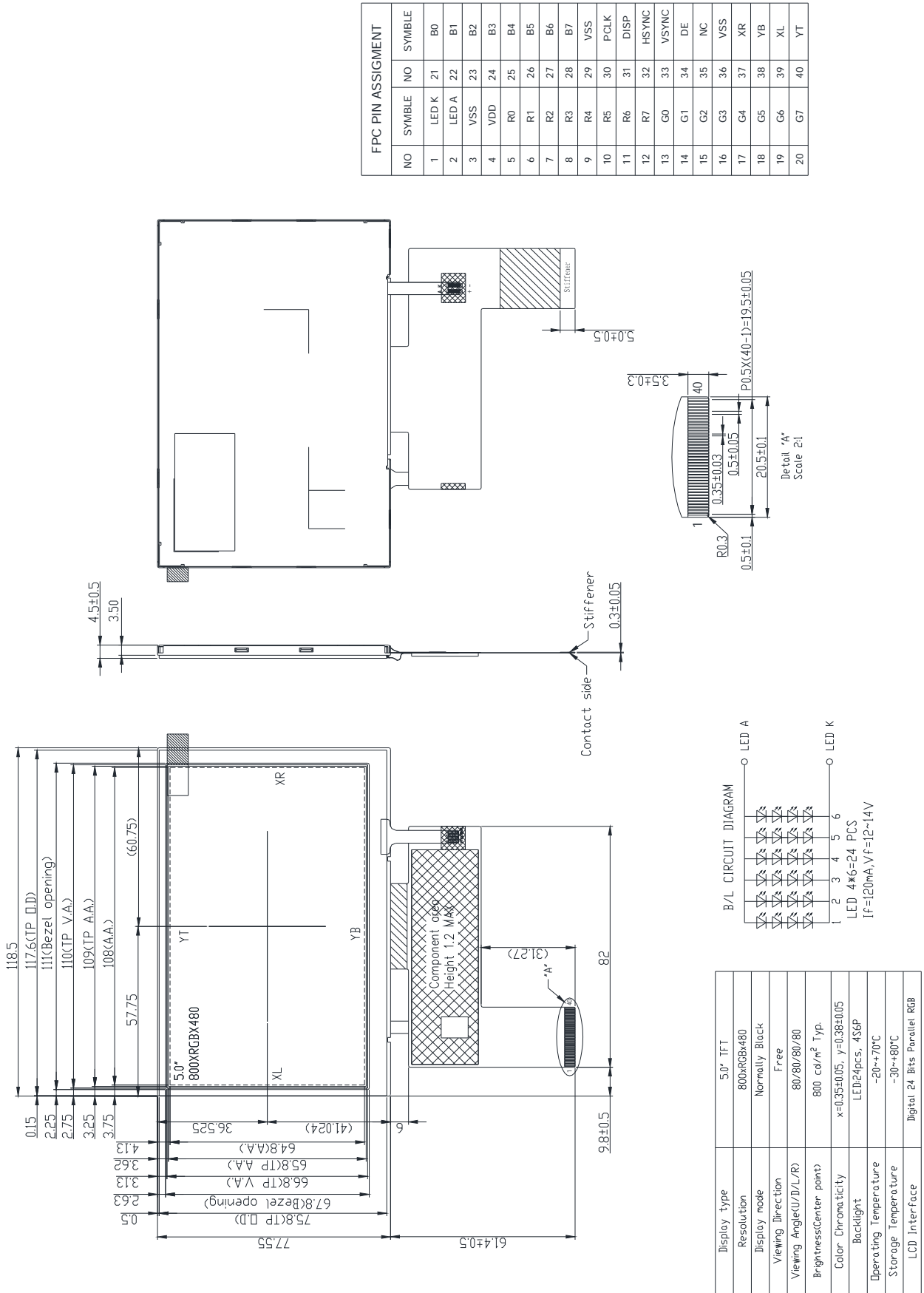

13 Incoming Inspection Standards

13.1 Inspection and Environment Conditions

13.1.1 Inspection Conditions:

- (1) Inspection Distance: 35 cm±5cm
- (2) View Angle : Light-on Inspection Angle : ±5°
Cosmetic Inspection Angle : ±45°

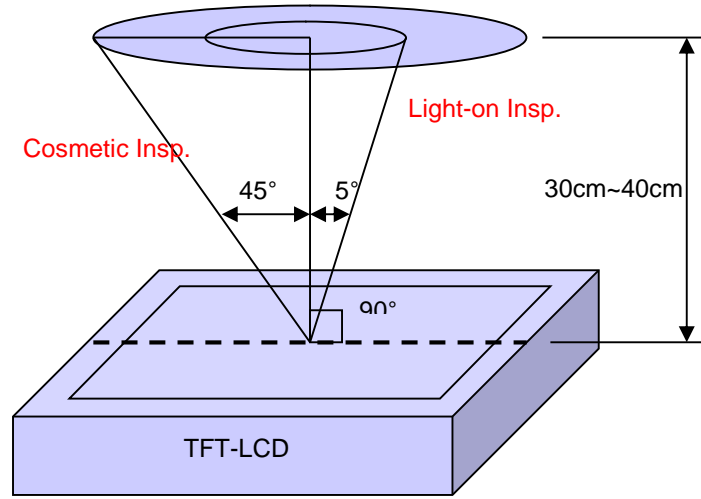

(perpendicular to LCD panel surface)

13.1.2 Environment Conditions:

Ambient Temperature		23°C±5°C
Ambient Humidity		55±10%RH
Ambient Illumination	Cosmetic Inspection	more than 600 Lux
	Functional Inspection	300~500 Lux

13.1.3 Sampling Conditions:

- (1) Lot Size: Quantity of shipment lot per model
- (2) Sampling Method:

Sampling Plan		MIL-STD-105E
		Normal Inspection, Single Sampling
		Level II
AQL	Major Defect	1.0%
	Minor Defect	1.5%

- (3) The classification of Major(MA) and Minor(MI) defects is shown as 3. Inspection Criteria.

13.1.4 Inspection Criteria

13.1.4.1 Cosmetic Inspection(Panel):

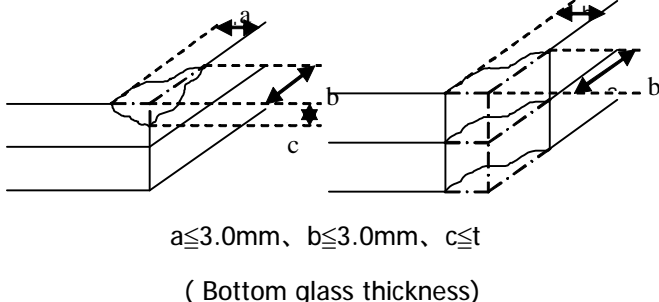
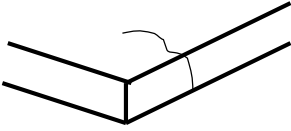
Item	Judgment Criteria	Classification
Chipping on Panel	 <p>$a \leq 3.0\text{mm}$, $b \leq 3.0\text{mm}$, $c \leq t$ (Bottom glass thickness)</p>	MA
Scratch on Panel *Note-2	<p>$W \leq 0.05\text{mm}$ or $L < 5\text{mm}$: Ignored</p> <p>$0.05\text{mm} < W \leq 0.1\text{mm}$ and $L \leq 5\text{mm}$: $N \leq 5$</p> <p>$W > 0.1\text{mm}$ or $L > 5\text{mm}$: Not allowed</p>	MI
Bubble or Dent on Panel *Note-3	<p>$D \leq 0.2\text{mm}$: Ignored</p> <p>$0.2\text{mm} < D \leq 0.3\text{mm}$: $N \leq 5$</p> <p>$D > 0.3\text{mm}$: Not allowed</p>	MI
Panel Crack	 <p>Not Allowed crack</p>	MA
Bezel Deformation	Obvious deformation is not allowed.	MI
Bezel Oxidation	Not allowed if it rusts continuously over 1 cm (It is out of warranty with rusted tin plate)	MI
Bezel Scratch	$L \leq 20\text{mm}$, $W \leq 0.2$, $N \leq 3$	MI
Metal Squash Dent /Flange(Front Side)	$D(W) \leq 1$, $L \leq 3$, $N \leq 3$;	MI
B/L High Voltage Wire Denudation	Not allowed	MA
Polarizer Flaw or Leak out Resin	Defect is defined as the active area.	MI
Outline Dimension	Must in Spec, refer to related product spec.	MI

13.1.4.2 Functional Inspection:

Item	Judgment Criteria			Classification
	Area(Note1)	I	O	
Point Defect	Bright Dot	Random	2	
		2 dots adjacent	0	0
		3 dots adjacent or more	0	0
	Dark Dot	Random	3	
		2 dots adjacent	0	
		3 dots adjacent or more	0	0
	Total Dot Defect		5	
	Distance	Distance between Bright and Bright dot	L ≤ 5mm	
		Distance between Bright and Dark dot	L ≤ 5mm	
		Distance between Dark dot	L ≤ 5mm	
(1) It is defined as Point Defect if defect area > 0.5dot (2) It is ignored if defect area ≤ 0.5dot (3) Weak point defect will be defined as Bright Dot if it can be observed through ND filter 5%(Full Screen Black Inspection)				MI
Line Defect	Obvious vertical or horizontal line defect is not allowed.			
Mura	Not allowed if it can be observed through ND Filter 5 %			
Foreign Material in spot shape *Note-3	D ≤ 0.05mm: Ignored 0.05mm < D ≤ 0.1mm: N ≤ 3 D > 0.1mm: Not allowed			
Foreign Material in line or spiral shape *Note-4	W ≤ 0.05mm or L ≤ 2mm: Ignored 0.05mm < W ≤ 0.1mm and L ≤ 1mm: N ≤ 2 W > 0.1mm or L > 2mm: Not allowed			
Display Function Abnormal	No Malfunction can be allowed			

Note-1 : I/O Area Definition

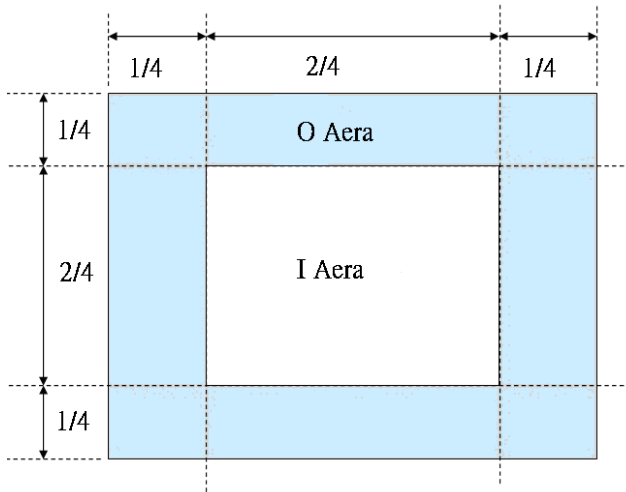

Note-2 : Polarizer Scratch

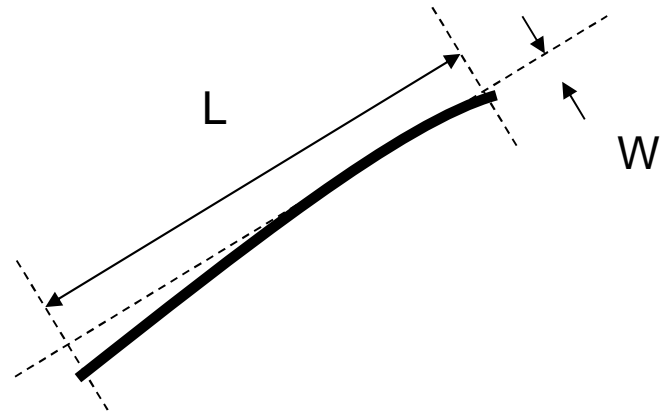

Note-3 : Spot Foreign Material
($W \geq L / 4$)

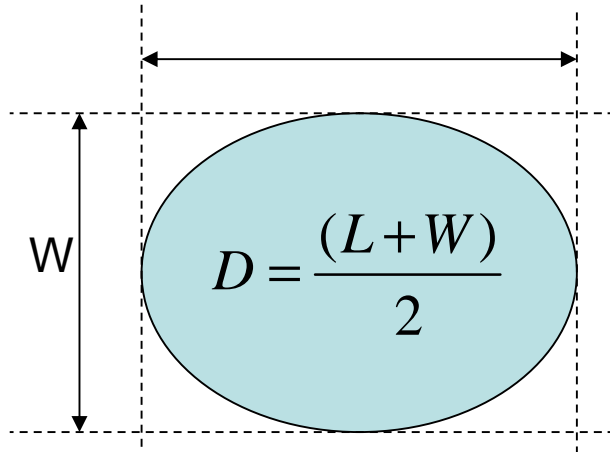

Note-4 : Line or Spiral Foreign Material
($W < L / 4$)

