

**DISPLAY Elektronik GmbH**

# DATA SHEET

*TFT MODULE*

**DEM 640480I VMH-PW-N**

**5,7“- TFT**

**Product Specification**

**Version: 0**

**26.03.2024**

**Revision History**

<b>VERSION</b>	<b>DATE</b>	<b>REVISED PAGE NO.</b>	<b>Note</b>
0	26.03.2024		First issue

# Contents

- 1.Summary
- 2.General Specifications
- 3.Interface
- 4.Contour Drawing
- 5.Absolute Maximum Ratings
- 6.Electrical Characteristics
- 7.Timing Characteristics
- 8.Power Sequence
- 9.Optical Characteristics
- 10.Reliability
- 11.Other

## **1.Summary**

TFT 5.7" is a TFT-LCD module. It is composed of a TFT-LCD panel, driver IC ,FPC, a backlight unit. The 5.7 display area contains 640 x 480pixels and can display up to 16.7M colors. This product accords with RoHS environmental criterion.

## **2.General Specifications**

- n Size: 5.7 inch
- n Dot Matrix: 640 x RGBx480(TFT) dots
- n Module dimension: 124.7 x 100.0 x 5.91 mm
- n Active area: 115.2 x 86.4 mm
- n Pixel pitch: 0.18 x 0.18 mm
- n LCD type: TFT, Normally black, Transmissive
- n View Angle: 80/80/80/80
- n TFT Driver IC: JD9168S or Equivalent
- n TFT interface: RGB18bits SYNC+DE mode
- n Aspect Ratio: 4:3
- n Backlight Type: LED ,Normally White
- n With /Without TP: Without TP
- n Surface: Anti-Glare

\*Color tone slight changed by temperature and driving voltage.

### 3.Interface

#### 3.1. LCM PIN Definition

Pin	Symbol	I/O	Function	Remark
1	GND	P	Ground.	
2	VCC	P	Power supply for TFT	
3	VCC	P	Power supply for TFT	
4	GND	P	Ground.	
5	NC	-	No connection	
6	GND	P	Ground.	
7	NC	-	No connection	
8	GND	P	Ground.	
9	UD	I	Up/down selection	
10	LR	I	Left /right selection	
11	/CSX	I	Chip select pin. 0: Chip can be accessed; 1: Chip cannot be accessed. If this pin is not used, please connect it to VCC.	
12	SCL	I	Serial clock input in SPI interface .If not use, let it open or VCC or GND.	
13	SDA	I	Serial data input / output pin in SPI interface operation. If not use, let it open.	
14	NC	-	No connection	
15	GND	P	Ground.	
16	B5	I	Blue Data bus	
17	B4	I	Blue Data bus	
18	B3	I	Blue Data bus	
19	B2	I	Blue Data bus	
20	B1	I	Blue Data bus	
21	B0	I	Blue Data bus	
22	NC	-	No connection	
23	NC	-	No connection	
24	GND	P	Ground.	
25	G5	I	Green Data bit	
26	G4	I	Green Data bit	
27	G3	I	Green Data bit	
28	G2	I	Green Data bit	
29	G1	I	Green Data bit	

30	G0	I	Green Data bit	
31	NC	-	No connection	
32	NC	-	No connection	
33	GND	P	Ground.	
34	NC	-	No connection	
35	NC	-	No connection	
36	GND	P	Ground.	
37	R5	I	Red Data bit	
38	R4	I	Red Data bit	
39	R3	I	Red Data bit	
40	R2	I	Red Data bit	
41	R1	I	Red Data bit	
42	R0	I	Red Data bit	
43	VLED-	P	Power supply for LED cathode	
44	VLED+	P	Power supply for LED anode	
45	DE	I	Data enable input in RGB interface.	
46	CLK	I	Pixel clock input in RGB interface.	
47	HS	I	Horizontal sync input in RGB interface.	
48	VS	I	Vertical sync input in RGB interface	
49	NC	-	No connection	
50	GND	P	Ground.	

### 4. Contour Drawing

PN.NO	SYMBOL	PN.NO	SYMBOL
1	GND	26	G4
2	VCC	27	G3
3	VCC	28	G2
4	GND	29	G1
5	NC	30	G0
6	GND	31	NC
7	NC	32	NC
8	GND	33	GND
9	UD	34	NC
10	LR	35	NC
11	/CSX	36	GND
12	SCL	37	R5
13	SDA	38	R4
14	NC	39	R3
15	GND	40	R2
16	B5	41	R1
17	B4	42	R0
18	B3	43	VLED-
19	B2	44	VLED+
20	B1	45	DE
21	B0	46	CLK
22	NC	47	HS
23	NC	48	VS
24	GND	49	NC
25	G5	50	GND

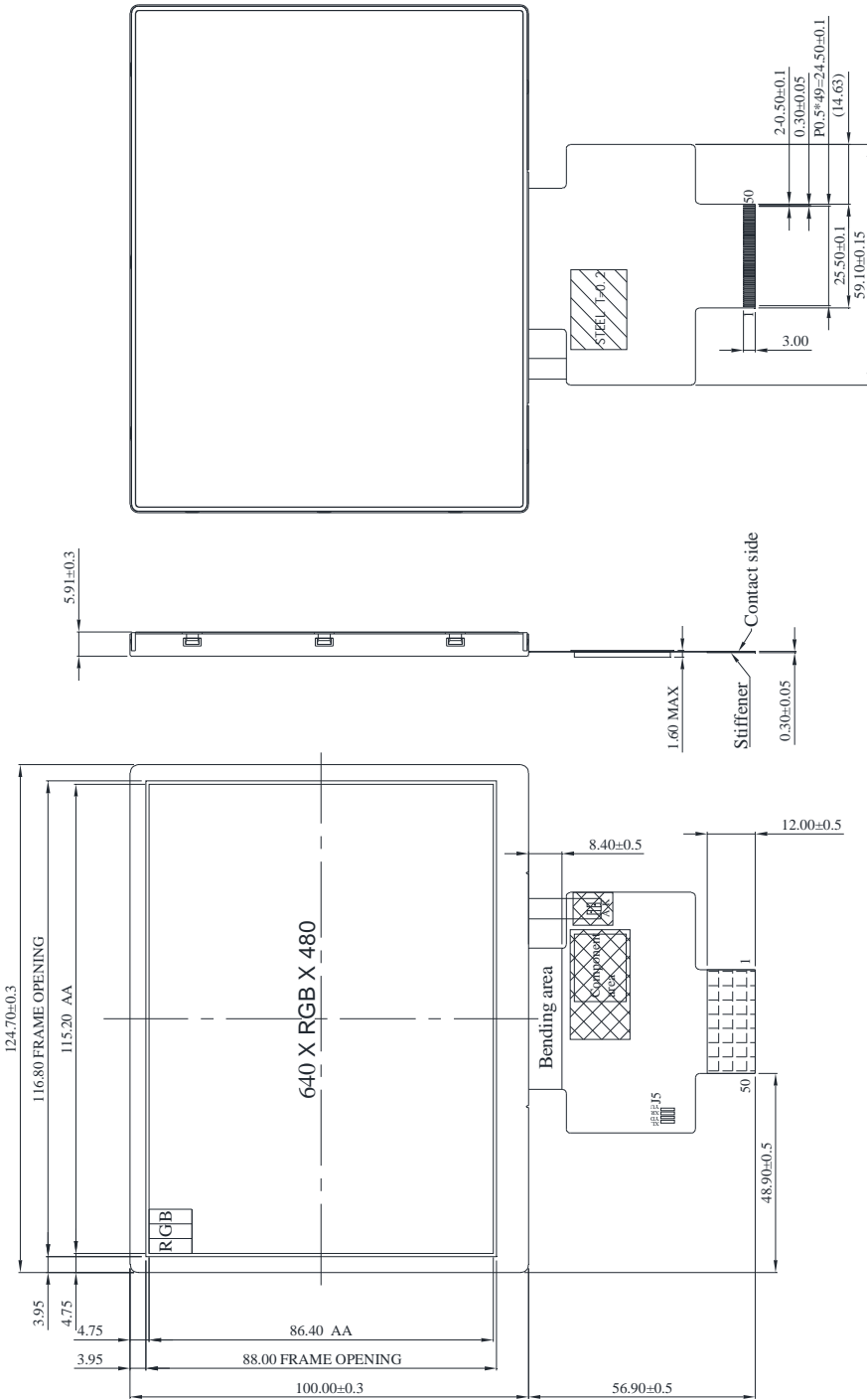

The non-specified tolerance of dimension is ±0.3 mm .



**5. Absolute Maximum Ratings**

Item	Symbol	Min	Typ	Max	Unit
Operating Temperature	TOP	-20	-	+70	°C
Storage Temperature	TST	-30	-	+80	°C

Note: Device is subject to be damaged permanently if stresses beyond those absolute maximum ratings listed above

1. Temp.  $\leq 60^{\circ}\text{C}$ , 90% RH MAX. Temp.  $> 60^{\circ}\text{C}$ , Absolute humidity shall be less than 90% RH at  $60^{\circ}\text{C}$

## 6. Electrical Characteristics

### 6.1. Operating conditions:

Parameter	Symbol	Condition	Min	Typ	Max	Unit	Note
Supply Voltage	VCC	Ta=25°C	3.0	3.3	3.6	V	
Input voltage	H	VCC=3.0V	0.7VCC	-	VCC		
	L	VCC=3.0V	0	-	0.3VCC	mW	
Power supply Current (Operating)	ICC	VCC=3.0V	-	50	75	mA	1

Note1 ALL White Display pattern

### 6.2. LED driving conditions

Parameter	Symbol	Min.	Typ.	Max.	Unit	Remark
LED current	-	-	80	-	mA	-
Power Consumption	-	1344	1440	1536	mW	-
LED voltage	VLED+	16.8	18.0	19.2	V	Note 1
LED Life Time	-	-	50,000	-	Hr	Note 2,3,4

Note 1 : There are 1 Groups LED

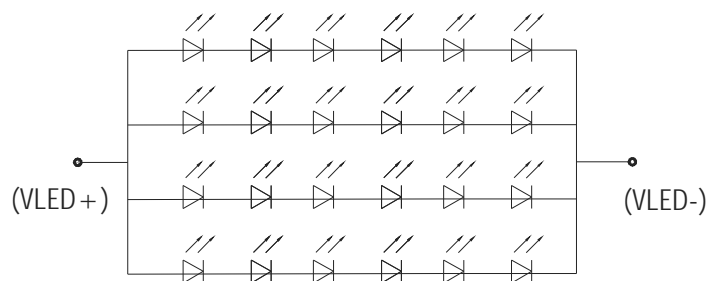

Back Light Circuit

Note 2 : Ta = 25 °C

Note 3 : Brightness to be decreased to 50% of the initial value

Note 4 : The single LED lamp case

## 7. Timing Characteristics

### RGB Interface

#### Vertical Timings

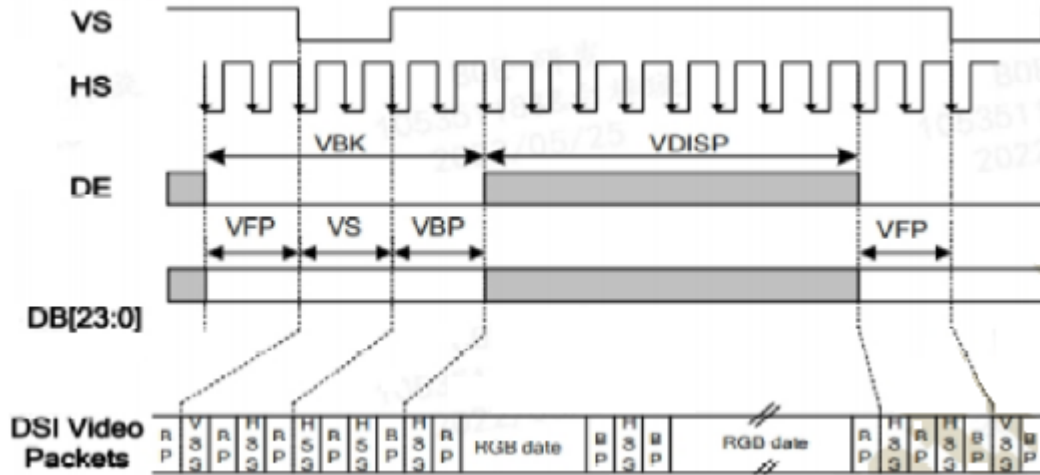

#### Horizontal Timings

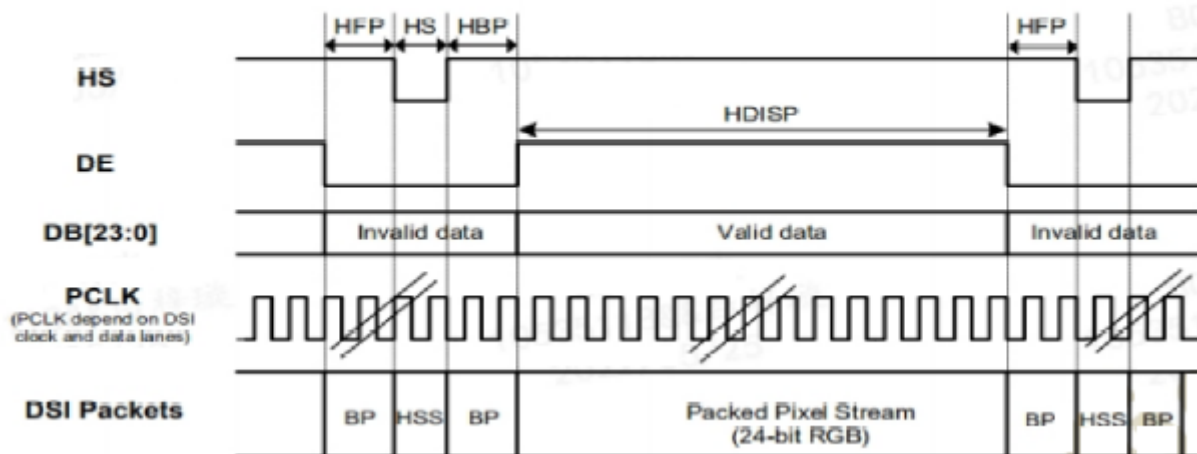

Signal	Item	Symb ol	Min	Typ	Max	Unit	Note
PCLK	Frequency	Fc	18	20	27	MHZ	
Vertical Active Display Term	Total	Tv	501	518	535	Th	Tv=VDISP+VBK
	Display	VDIS P		480		Th	
	Blank	VBK	21	38	55	Th	VBK=VS+VBP+VFP
Horizontal Active Display Term	Total	Th	652	664	700	Tc(*)	Th=HDISP+HBLK
	Display	HDIS P		640		Tc(*)	
	Blank	HBLK	12	24	60	Tc(*)	HBLK=HS+HBP+HFP

Tc: PCLK cycle time.

### 8.Power Sequence

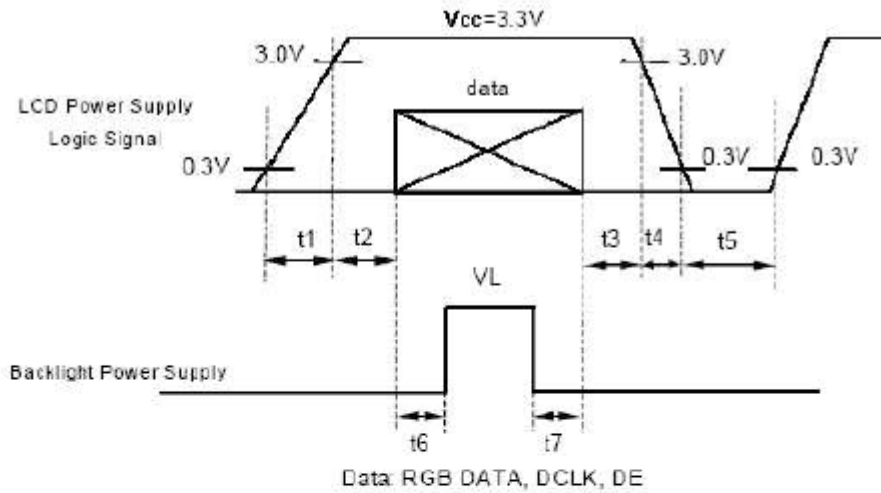

\*2) VCC-dip condition:

(1)  $2.7V \leq V_{CC} < 3.0V, t_d \leq 10ms$

(2)  $V_{CC} > 3.0V, V_{CC}$ -dip condition should be the same with VCC-turn-on condition .

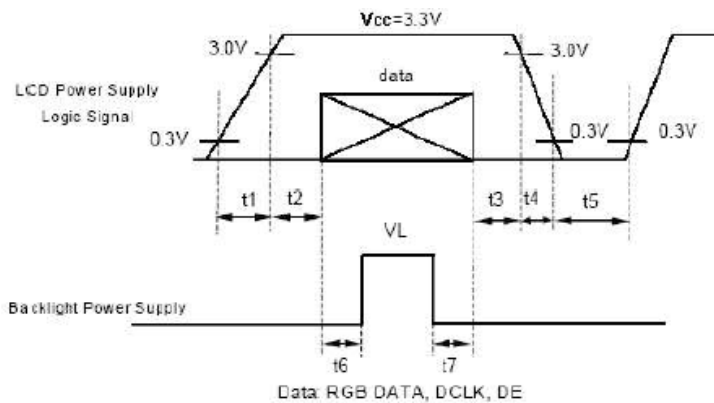
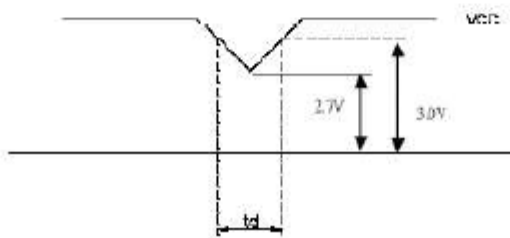

\*2) VCC-dip condition:

(1)  $2.7V \leq V_{CC} < 3.0V, t_d \leq 10ms$

(2)  $V_{CC} > 3.0V, V_{CC}$ -dip condition should be the same with VCC-turn-on condition .

$t_1 \leq 10ms$  :  $1sec \leq t_5$   
 $50ms \leq t_2$  :  $200ms \leq t_6$   
 $0 < t_3 \leq 50ms$ :  $200ms \leq t_7$   
 $0 < t_4 \leq 10ms$

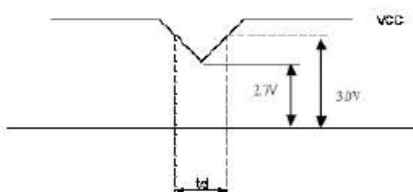

### 9.Optical Characteristics

Item	Symbol	Condition.	Min	Typ.	Max.	Unit	Remark	
Response time	Tr+ Tf	$\theta=0^\circ$ 、 $\Phi=0^\circ$	-	30	35	ms	Note 3	
Contrast ratio	CR	At optimized viewing angle	1000	1200	-	-	Note 4	
Color Chromaticity	White	Wx	$\theta=0^\circ$ 、 $\Phi=0$	0.242	0.292	0.342	-	Note 2,6,7
		Wy		0.287	0.337	0.387	-	
Viewing angle	Hor.	$\Theta_R$	$CR \geq 10$	-	80	-	Deg.	Note 1
		$\Theta_L$		-	80	-		
	Ver.	$\Phi_T$		-	80	-		
		$\Phi_B$		-	80	-		
Brightness	-	-	360	500	-	cd/m <sup>2</sup>	Center of display	
Uniformity	(U)	-	70	-	-	%	Note5	

Ta=25±2°C, IL=80mA

Note 1: Definition of viewing angle range

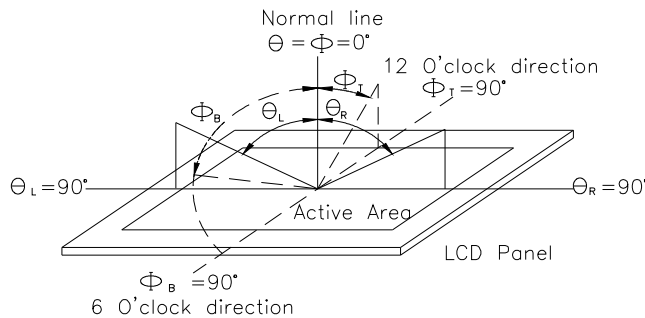
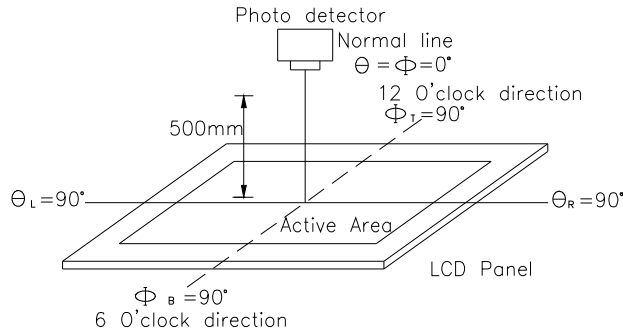

Fig.10.1. Definition of viewing angle

Note 2: Test equipment setup:

After stabilizing and leaving the panel alone at a driven temperature for 10 minutes, the measurement should be executed. Measurement should be executed in a stable, windless, and dark room. Optical specifications are measured by Topcon BM-7orBM-5 luminance meter 1.0° field of view at a distance of 50cm and normal direction.



**Fig. 10.2. Optical measurement system setup**

**Note 3: Definition of Response time:**

The response time is defined as the LCD optical switching time interval between “White” state and “Black” state. Rise time,  $T_r$ , is the time between photo detector output intensity changed from 90% to 10%. And fall time,  $T_f$ , is the time between photo detector output intensity changed from 10% to 90%

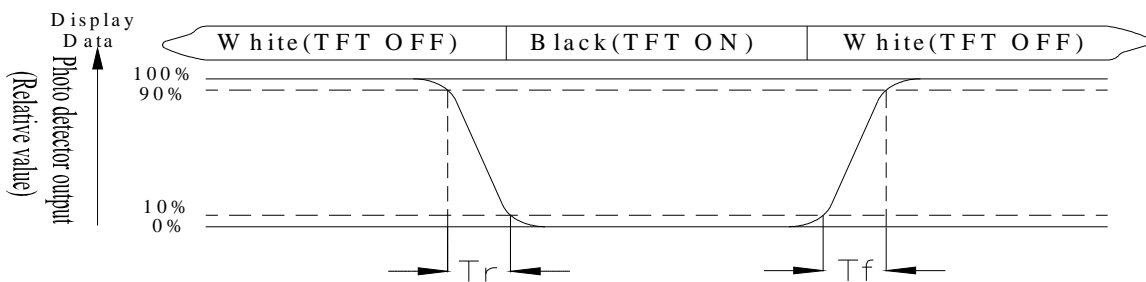

**Note 4: Definition of contrast ratio:**

The contrast ratio is defined as the following expression.

$$\text{Contrast ratio (CR)} = \frac{\text{Luminance measured when LCD on the "White" state}}{\text{Luminance measured when LCD on the "Black" state}}$$

**Note 5: Definition of Luminance Uniformity**

Active area is divided into 9 measuring areas (reference the picture in below). Every measuring point is placed at the center of each measuring area.

$$\text{Luminance Uniformity (U)} = \text{Lmin/Lmax} \times 100\%$$

L = Active area length

W = Active area width

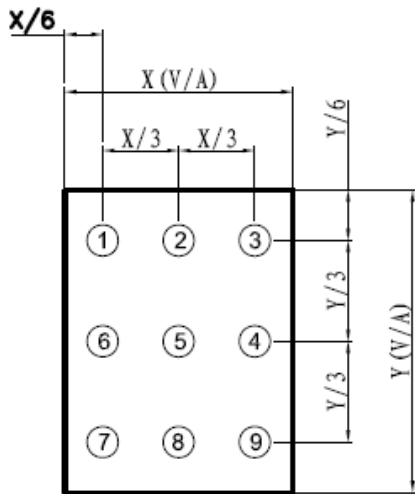

Fig10.3. . Definition of uniformity

Note 6: Definition of color chromaticity (CIE 1931)

Color coordinates measured at the center point of LCD

Note 7: Measured at the center area of the panel when all the input terminals of LCD panel are electrically opened.

## 10. Reliability

Content of Reliability Test (Wide temperature, -20°C~70°C)

Environmental Test			
Test Item	Content of Test	Test Condition	Note
High Temperature storage	Endurance test applying the high storage temperature for a long time.	80°C 200hrs	2
Low Temperature storage	Endurance test applying the low storage temperature for a long time.	-30°C 200hrs	1,2
High Temperature Operation	Endurance test applying the electric stress (Voltage & Current) and the thermal stress to the element for a long time.	70°C 200hrs	—
Low Temperature Operation	Endurance test applying the electric stress under low temperature for a long time.	-20°C 200hrs	1
High Temperature/ Humidity Operation	The module should be allowed to stand at 60°C,90%RH max	60°C,90%RH 96hrs	1,2
Thermal shock resistance	The sample should be allowed stand the following 10 cycles of operation <div style="text-align: center;"> <span style="margin-right: 20px;">-20°C</span> <span style="margin-right: 20px;">25°C</span> <span style="margin-right: 20px;">70°C</span> </div> 	-20°C/70°C 10 cycles	—
Vibration test	Endurance test applying the vibration during transportation and using.	Total fixed amplitude : 1.5mm Vibration Frequency : 10~55Hz One cycle 60 seconds to 3 directions of X,Y,Z for Each 15 minutes	3
Static electricity test	Endurance test applying the electric stress to the finished product housing.	VS=±4KV(contact), ±8KV(air) RS=330Ω CS=150pF 10 times	

Note1: No dew condensation to be observed.

Note2: The function test shall be conducted after 4 hours storage at the normal Temperature and humidity after remove from the test chamber.

Note3: The packing have to including into the vibration testing.