

**Display Elektronik GmbH**

*DATA  
SHEET*

**TFT MODULE**

**DEM 480480J VMH-PW-N  
(C-TOUCH)  
(ROUND 2,76“ TFT + C-TP)**

Product Specification

Version: 0

17.01.2024

**Revision History**

| Date       | Rev. No. | Page | Summary     |
|------------|----------|------|-------------|
| 17.01.2025 | 0        | ALL  | FIRST ISSUE |
|            |          |      |             |
|            |          |      |             |
|            |          |      |             |
|            |          |      |             |
|            |          |      |             |
|            |          |      |             |
|            |          |      |             |
|            |          |      |             |
|            |          |      |             |
|            |          |      |             |
|            |          |      |             |
|            |          |      |             |
|            |          |      |             |
|            |          |      |             |
|            |          |      |             |
|            |          |      |             |
|            |          |      |             |
|            |          |      |             |
|            |          |      |             |
|            |          |      |             |
|            |          |      |             |
|            |          |      |             |
|            |          |      |             |
|            |          |      |             |
|            |          |      |             |
|            |          |      |             |

## Contents

|  |           |
|--|-----------|
| <b>1. Basic Specifications</b>               | <b>4</b>  |
| 1.1 TFT Features                             | 4         |
| 1.2 CTP Features                             | 4         |
| 1.3 Mechanical Information                   | 5         |
| <b>2. Block Diagram</b>                      | <b>5</b>  |
| <b>3. Outline Dimension</b>                  | <b>6</b>  |
| <b>4. Input terminal Pin Assignment</b>      | <b>7</b>  |
| 4.1 TFT PIN Definition                       | 7         |
| 4.2 CTP PIN Definition                       | 8         |
| <b>5. LCD Optical Characteristics</b>        | <b>9</b>  |
| 5.1 Optical Specification                    | 9         |
| <b>6. Electrical Characteristics</b>         | <b>12</b> |
| 6.1 Absolute Maximum Rating                  | 12        |
| 6.2 DC Electrical Characteristics            | 12        |
| 6.3 MIPI DC Electrical Characteristics       | 13        |
| 6.4 LED Backlight Characteristics            | 14        |
| <b>7. AC Characteristics</b>                 | <b>16</b> |
| 7.1 MIPI Interface Characteristics:          | 16        |
| 7.2 Reset Timing                             | 20        |
| <b>8. CTP Specification</b>                  | <b>21</b> |
| 8.1 Electrical Characteristics               | 21        |
| 8.2 AC Electrical Characteristics            | 22        |
| 8.3 SYSTEM MANAGEMENT                        | 23        |
| <b>9. LCD Module Out-Going Quality Level</b> | <b>24</b> |
| 9.1 VISUAL & FUNCTION INSPECTION STANDARD    | 24        |
| <b>10. Reliability Test Result</b>           | <b>32</b> |
| <b>11. Cautions and Handling Precautions</b> | <b>33</b> |
| 11.1 Handling and Operating the Module       | 33        |
| 11.2 Storage and Transportation.             | 33        |

## 1. Basic Specifications

### \* Description

This is a color active matrix TFT (Thin Film Transistor) LCD (liquid crystal display) that uses amorphous silicon TFT as a switching device. This module is composed of a transmissive type TFT-LCD Panel, driver circuit, capacitance touch panel, backlight unit. The resolution of a 2.76" TFT-LCD contains 480xRGBx480 Pixels and can display up to 16.7 Million colors.

### 1.1 TFT Features

| General Information Items        | Specification                      | Unit    | Note |
|----------------------------------|------------------------------------|---------|------|
|                                  | Main Panel                         |         |      |
| Display Area (AA)                | 70.13 x 70.13 (2.76 Inch)          | mm      | -    |
| Driver Element                   | TFT Active Matrix                  | -       | -    |
| Display Colors                   | 16.7 Million                       | colors  | -    |
| Number of Pixels                 | 480 x RGB x 480                    | dots    | -    |
| Pixel Arrangement                | RGB Vertical Stripe                | -       | -    |
| Pixel Pitch                      | 0.1461 x 0.1461                    | mm      | -    |
| Viewing Angle                    | ALL                                | o'clock | -    |
| Controller IC                    | ST7701S (Sitronix)                 | -       | -    |
| LCM Interface                    | 2-Lane MIPI                        | -       | -    |
| Display Mode                     | IPS, Transmissive / Normally Black | -       | -    |
| Operating Temperature            | -20°C ~ +70°C                      | °C      | -    |
| Storage Temperature              | -30°C ~ +80°C                      | °C      | -    |
| Touch and LCM Bonding technology | Optical bonding                    | -       | -    |

### 1.2 CTP Features

| General Information Items | Specification      | Unit | Note |
|---------------------------|--------------------|------|------|
|                           | Main Panel         |      |      |
| Resolution                | 480 x 480          | -    | -    |
| Structure                 | G+F+F              | -    | -    |
| Controller IC             | ST1633i (Sitronix) | -    | -    |
| Interface                 | I2C                | -    | -    |
| Slave Address             | 0x70               | -    | -    |
| Touch Mode                | Multi-Touch        | -    | -    |
| Logic Level               | 3.3                | -    | -    |

# DEM 480480J VMH-PW-N(C-TOUCH) Product Specification

## 1.3 Mechanical Information

| Item        |               | Min. | Typ.  | Max. | Unit | Note |
|-------------|---------------|------|-------|------|------|------|
| Module Size | Horizontal(H) | -    | 87.73 | -    | mm   | -    |
|             | Vertical(V)   | -    | 89.73 | -    | mm   | -    |
|             | Depth(D)      | -    | 3.39  | -    | mm   | -    |
| Weight      |               | -    | 34    | -    | g    | -    |

## 2. Block Diagram

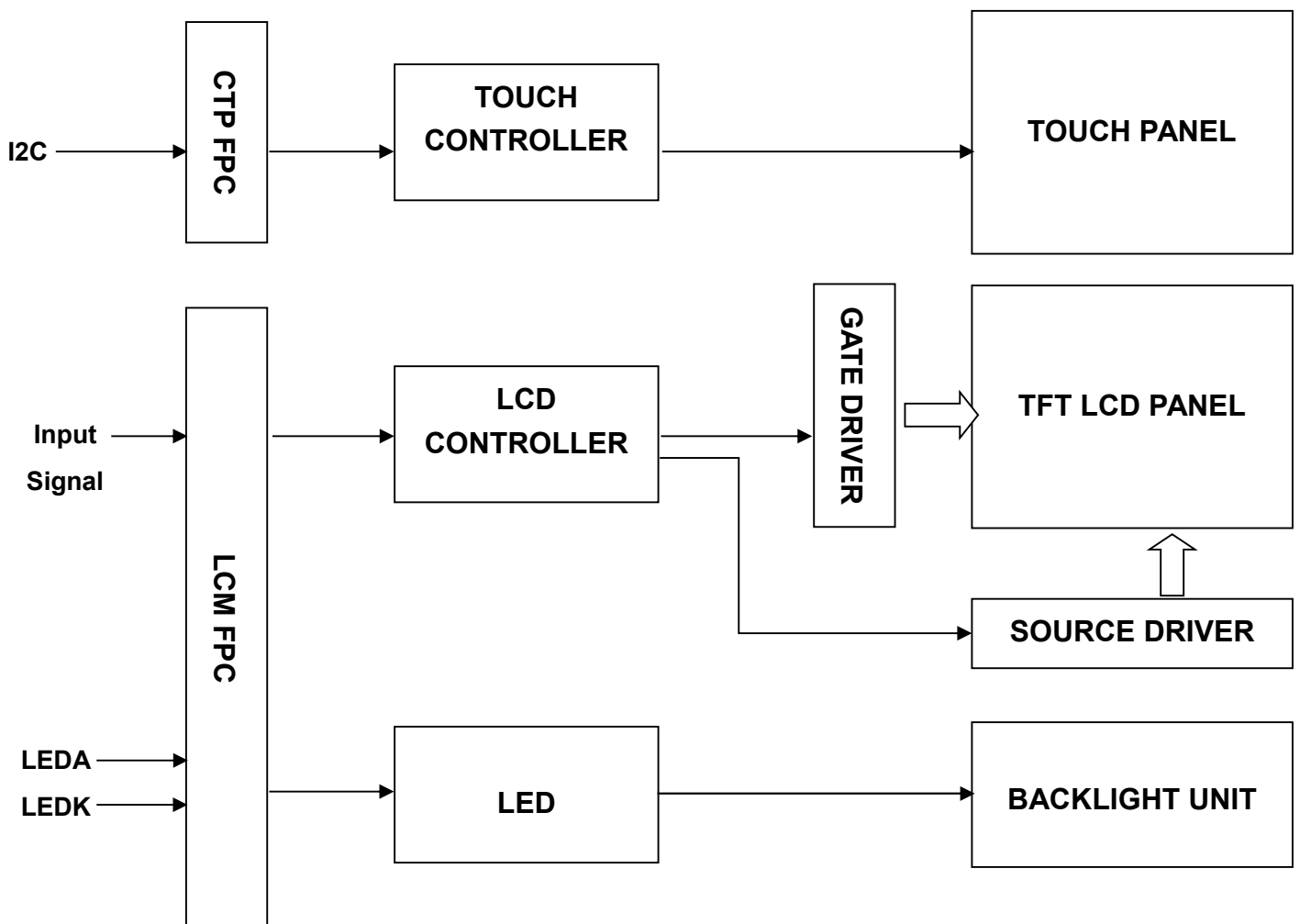

# DEM 480480J VMH-PW-N(C-TOUCH) Product Specification

## 3. Outline Dimension

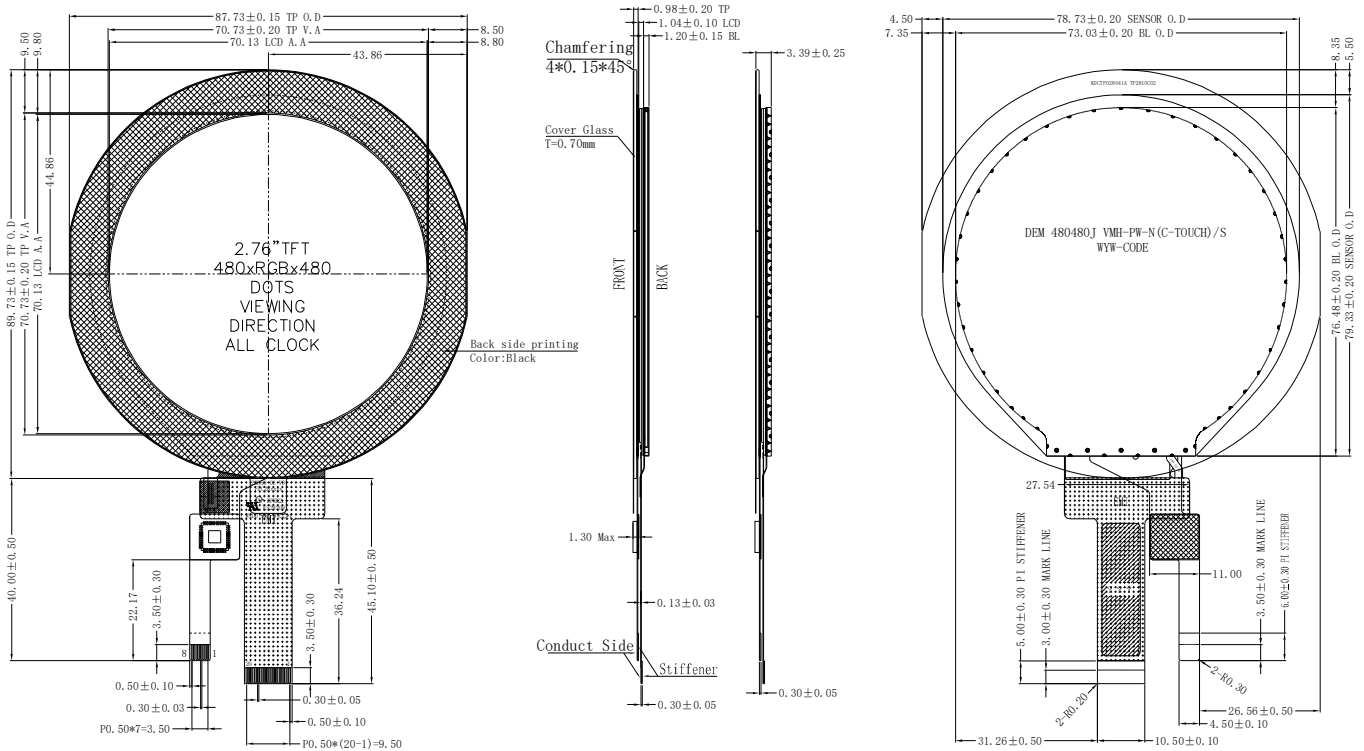

Note: The opening of top case must be less than LCD POL 0.3mm at least, the LCD V.A. is the Recommended opening of Lens.

### NOTE:

1. DISPLAY TYPE: 2.76", TFT-LCD, 16.7M COLORS
2. DISPLAY MODE: NORMALLY BLACK/IPS
3. VIEWING DIRECTION: ALL
4. LCM DRIVER IC: ST7701 (COG)  
LCM Interface: 2-Lane MIPI
5. Touch Mode: CTP  
Touch Driver IC: ST1633i  
Touch Interface: IIC  
Touch And LCM Bonding Technology: Optical Bonding
6. VDD/VCI: 3.3V (TYP.), IOVCC: 1.65-3.3V
7. OPERATING TEMP: -20° C TO 70° C  
STORAGE TEMP: -30° C TO 80° C
8. BACK LIGHT: LED WHITE, 4 LED, 80mA, 5.4-6.6V
9. RoHS COMPLIANT.

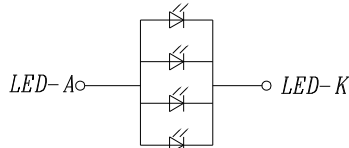

B/L Circuit

| Pin | Logic |
|-----|-------|
| 1   | GND   |
| 2   | NC    |
| 3   | VDD   |
| 4   | SCL   |
| 5   | SDA   |
| 6   | INT   |
| 7   | RST   |
| 8   | GND   |

| NO. | Pin Name |
|-----|----------|
| 1   | NC       |
| 2   | LEDK     |
| 3   | NC       |
| 4   | LEDA     |
| 5   | NC       |
| 6   | VDD/VCI  |
| 7   | IOVCC    |
| 8   | TE       |
| 9   | RESET    |
| 10  | GND      |
| 11  | MIPI_D1P |
| 12  | MIPI_D1N |
| 13  | GND      |
| 14  | MIPI_CLP |
| 15  | MIPI_CLN |
| 16  | GND      |
| 17  | MIPI_D0P |
| 18  | MIPI_D0N |
| 19  | GND      |
| 20  | GND      |

## 4. Input terminal Pin Assignment

### 4.1 TFT PIN Definition

| NO | SYMBOL   | DISCRIPTION  | I/O |
|----|----------|--|-----|
| 1  | NC       | --   | --  |
| 2  | LEDK     | Cathode pin of backlight.  | P   |
| 3  | NC       | --   | --  |
| 4  | LEDA     | Anode pin of backlight.  | P   |
| 5  | NC       | --   | --  |
| 6  | VDD/VCI  | Supply Voltage (3.3V).   | P   |
| 7  | IOVCC    | I/O power supply voltage.  | P   |
| 8  | TE       | -Tearing effect output<br>Leave the pin to open when not in use.   | O   |
| 9  | RESET    | - The external reset input.<br>Initializes the chip with a low input. Be sure to execute a power-on reset after supplying power. | I   |
| 10 | GND      | Ground.  | P   |
| 11 | MIPI_D1P | MIPI DSI differential data pair (DSI-Dn+/-).   | I/O |
| 12 | MIPI_D1N |  | I/O |
| 13 | GND      | Ground.  | P   |
| 14 | MIPI_CLP | MIPI DSI differential clock pair (DSI-CLK+/-).   | I   |
| 15 | MIPI_CLN |  | I   |
| 16 | GND      | Ground.  | P   |
| 17 | MIPI_D0P | MIPI DSI differential data pair (DSI-Dn+/-).   | I/O |
| 18 | MIPI_D0N |  | I/O |
| 19 | GND      | Ground.  | P   |
| 20 | GND      | Ground.  | P   |

# *DEM 480480J VMH-PW-N(C-TOUCH) Product Specification*

## 4.2 CTP PIN Definition

| NO | SYMBOL | DISCRIPTION                    | I/O |
|----|--------|--------------------------------|-----|
| 1  | GND    | Ground                         | P   |
| 2  | NC     | No Connection                  | --  |
| 3  | VDD    | Supply voltage                 | P   |
| 4  | SCL    | I2C clock input                | I   |
| 5  | SDA    | I2C data input and output      | I   |
| 6  | INT    | External interrupt to the host | I   |
| 7  | RST    | External Reset, Low is active  | I   |
| 8  | GND    | Ground                         | P   |



## 5. LCD Optical Characteristics

### 5.1 Optical Specification

| Item                         |         | Symbol                       | Condition                         | Min.  | Typ.  | Max.  | Unit.       | Note    |
|------------------------------|---------|------------------------------|-----------------------------------|-------|-------|-------|-------------|---------|
| Contrast Ratio               |         | CR                           | Θ=0<br>Normal<br>Viewing<br>Angle | 700   | 1000  | --    |             | *(1)(2) |
| Response<br>Time             | Rising  | T <sub>R+T<sub>F</sub></sub> |                                   | --    | 35    | 40    | msec        | *(1)(3) |
|                              | Falling |                              |                                   |       |       |       |             |         |
| Color Gamut                  |         | S(%)                         |                                   | 55    | 59    | --    | %           | *       |
| Color Filter<br>Chromaticity | White   | W <sub>X</sub>               |                                   | 0.237 | 0.277 | 0.317 | CA-310 Test |         |
|                              |         | W <sub>Y</sub>               |                                   | 0.238 | 0.278 | 0.318 |             |         |
|                              | Red     | R <sub>X</sub>               |                                   | 0.572 | 0.612 | 0.652 |             |         |
|                              |         | R <sub>Y</sub>               |                                   | 0.291 | 0.331 | 0.371 |             |         |
|                              | Green   | G <sub>X</sub>               |                                   | 0.266 | 0.306 | 0.346 |             |         |
|                              |         | G <sub>Y</sub>               |                                   | 0.511 | 0.551 | 0.591 |             |         |
|                              | Blue    | B <sub>X</sub>               | 0.109                             | 0.149 | 0.189 |       |             |         |
|                              |         | B <sub>Y</sub>               | 0.015                             | 0.055 | 0.095 |       |             |         |
| Viewing Angle                | Hor.    | Θ <sub>L</sub>               | CR>10                             | 80    | 85    | --    | *(1)(4)     |         |
|                              |         | Θ <sub>R</sub>               |                                   | 80    | 85    | --    |             |         |
|                              | Ver.    | Θ <sub>U</sub>               |                                   | 80    | 85    | --    |             |         |
|                              |         | Θ <sub>D</sub>               |                                   | 80    | 85    | --    |             |         |
| Option View Direction        |         | ALL                          |                                   |       |       |       |             |         |

\*The data comes from the LCD specification.

#### Measuring Condition

Measuring surrounding: dark room

Ambient temperature: 25°C±2°C

15min. warm-up time.

#### Measuring Equipment

FPM520 of Westar Display technologies, INC., which utilized SR-3 for Chromaticity and BM-5A for other optical characteristics.

# DEM 480480J VMH-PW-N(C-TOUCH) Product Specification

**Note (1):** Definition of Viewing Angle:

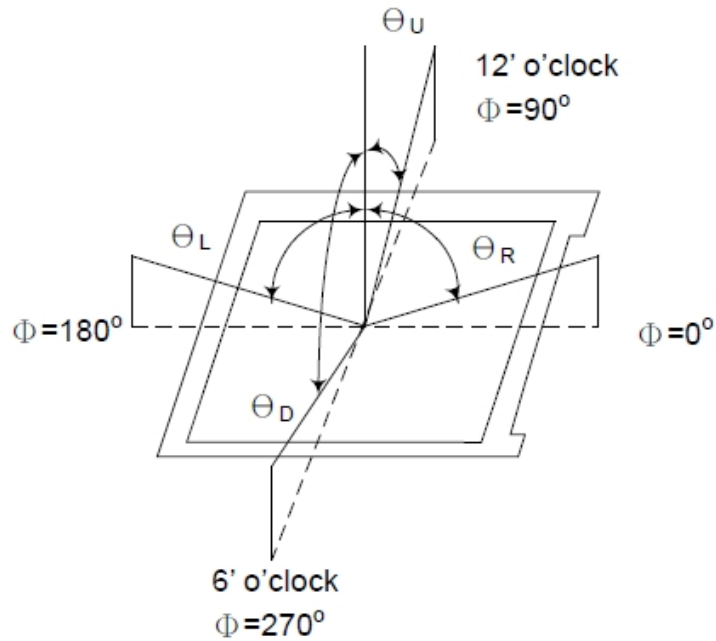

**Note (2):** Definition of Contrast Ratio(CR) :measured at the center point of panel

$$CR = \frac{\text{Luminance with all pixels white}}{\text{Luminance with all pixels black}}$$

**Note (3):** Response Time

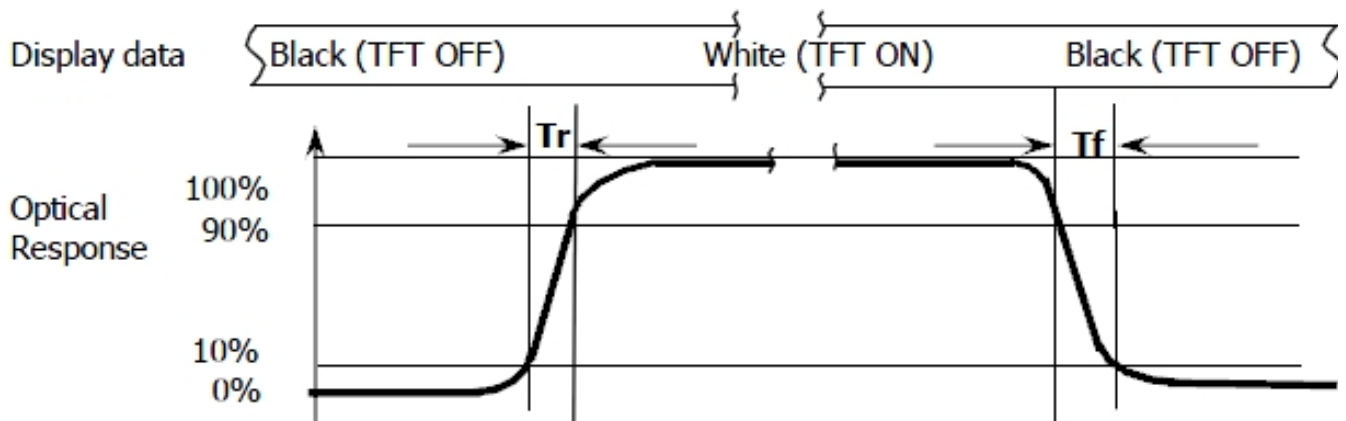

# *DEM 480480J VMH-PW-N(C-TOUCH) Product Specification*

**Note (4):** Definition of optical measurement setup

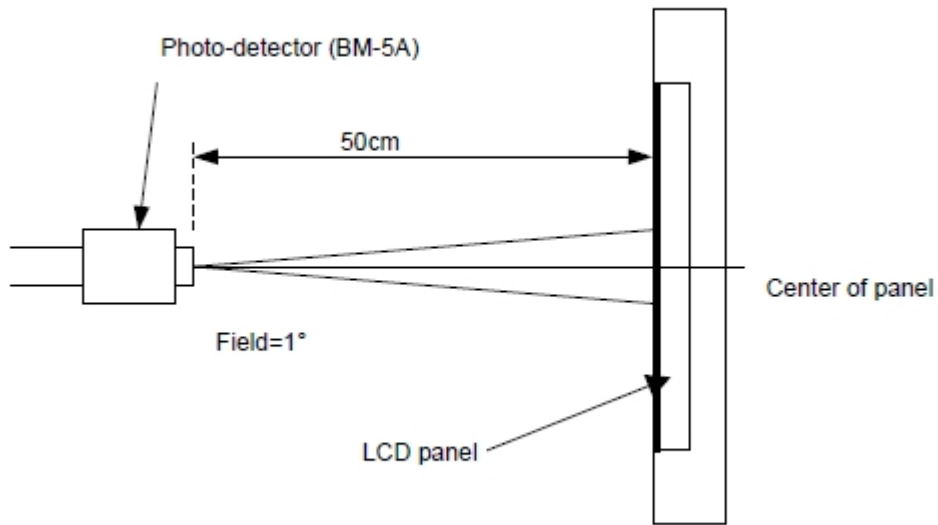

## 6. Electrical Characteristics

### 6.1 Absolute Maximum Rating

| Characteristics          | Symbol          | Min. | Max. | Unit | Note  |
|--------------------------|-----------------|------|------|------|-------|
| Digital Supply Voltage   | VCI             | -0.3 | 4.6  | V    | Note1 |
| Digital Interface Supply | IOVCC           | -0.3 | 4.6  | V    | -     |
| Operating Temperature    | T <sub>OP</sub> | -20  | +70  | °C   | -     |
| Storage Temperature      | T <sub>ST</sub> | -30  | +80  | °C   | -     |

NOTE1: If the absolute maximum rating of even is one of the above parameters is exceeded even momentarily, the quality of the product may be degraded. Absolute maximum ratings, therefore, specify the values exceeding which the product may be physically damaged. Be sure to use the product within the range of the absolute maximum ratings.

### 6.2 DC Electrical Characteristics

| Characteristics                                     | Symbol | Min. | Typ. | Max. | Unit | Note                       |
|---|--------|------|------|------|------|----------------------------|
| Digital Supply Voltage                              | VCI    | 2.5  | 3.3  | 3.6  | V    | -                          |
| Digital Interface Supply Voltage                    | IOVCC  | 1.65 | 1.8  | 3.3  | V    | -                          |
| Normal mode Current Consumption                     | ICC    | --   | 16   | 32   | mA   | -                          |
| Differential Input High Threshold Voltage           | VIT+   | --   | 0    | 50   | mV   | -<br>MIPI_CLK<br>MIPI_Data |
| Differential Input Low Threshold Voltage            | VIT-   | -50  | 0    | --   | mV   |                            |
| Single-ended Receiver Input Operation Voltage Range | VIR    | 0.5  | --   | 1.2  | V    |                            |

## 6.3 MIPI DC Electrical Characteristics

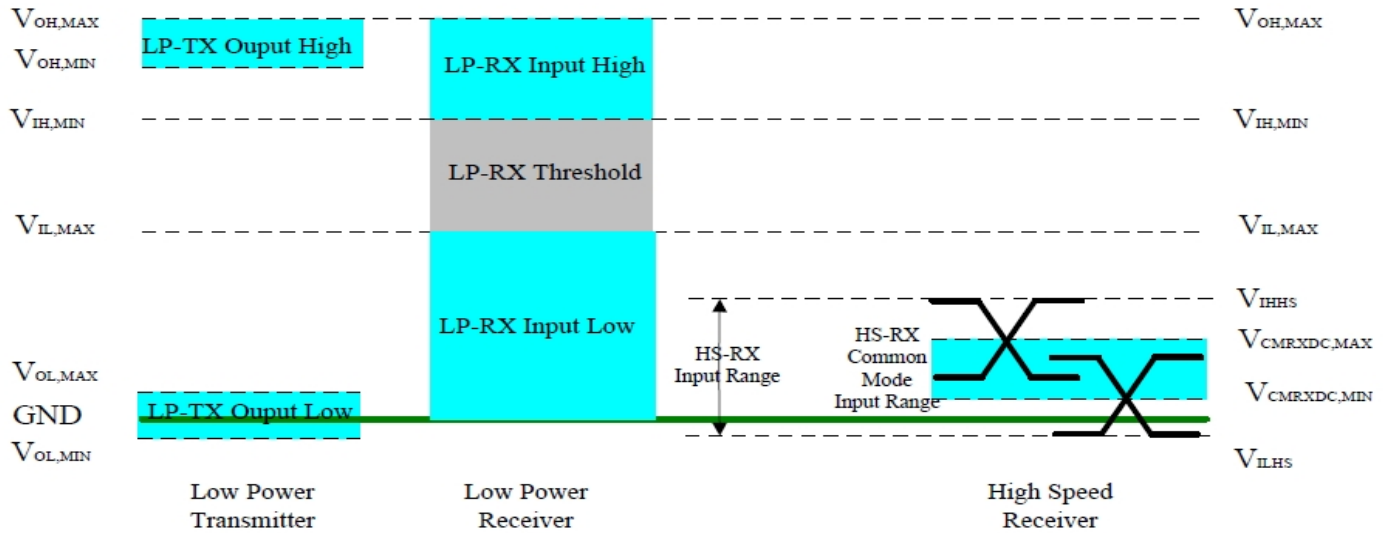

| Parameter                                    | Symbol       | Specification |     |      | Unit |
|--|--------------|---------------|-----|------|------|
|  |              | MIN           | TYP | MAX  |      |
| Operation Voltage for MIPI Receiver          |              |               |     |      |      |
| Low power mode operating voltage             | $V_{LPH}$    | 1.1           | 1.2 | 1.3  | V    |
| MIPI Characteristics for High Speed Receiver |              |               |     |      |      |
| Single-ended input low voltage               | $V_{ILHS}$   | -40           | -   | -    | mV   |
| Single-ended input high voltage              | $V_{IHHS}$   | -             | -   | 460  | mV   |
| Common-mode voltage                          | $V_{CMRXDC}$ | 70            | -   | 330  | mV   |
| Differential input impedance                 | $Z_{ID}$     | 80            | 100 | 125  | ohm  |
| MIPI Characteristics for Low Power Mode      |              |               |     |      |      |
| Pad signal voltage range                     | $V_I$        | -50           | -   | 1350 | mV   |
| Logic 0 input threshold                      | $V_{IL}$     | 0-            | -   | 550  | mV   |
| Logic 1 input threshold                      | $V_{IH}$     | 880           | -   | 1350 | mV   |
| Output low level                             | $V_{OL}$     | -50           | -   | 50   | mV   |
| Output high level                            | $V_{OH}$     | 1.1           | 1.2 | 1.3  | V    |

## 6.4 LED Backlight Characteristics

The backlight system is edge-lighting type with 4 chips LED

| Item            | Symbol | Min.  | Typ. | Max. | Unit              | Note    |
|-----------------|--------|-------|------|------|-------------------|---------|
| Forward Current | $I_F$  | --    | 80   | --   | mA                | --      |
| Forward Voltage | $V_F$  | 5.4   | --   | 6.6  | V                 | --      |
| LCM Luminance   | LV     | 450   | 500  | --   | cd/m <sup>2</sup> | Note3   |
| LED Lifetime    | Hr     | 50000 | --   | --   | Hour              | Note1,2 |
| Uniformity      | Avg    | 80    | --   | --   | %                 | Note3   |

Note1: LED life time (Hr) can be defined as the time in which it continues to operate under the condition:  $T_a=25^{\circ}\text{C}\pm 3^{\circ}\text{C}$ , typical IL value indicated in the above table until the brightness becomes less than 50%.

Note 2: The "LED life time" is defined as the module brightness decrease to 50% original brightness at  $T_a=25^{\circ}\text{C}$  and  $I_L=80\text{mA}$ . The LED lifetime could be decreased if operating  $I_L$  is larger than 80mA.

The constant current driving method is suggested.

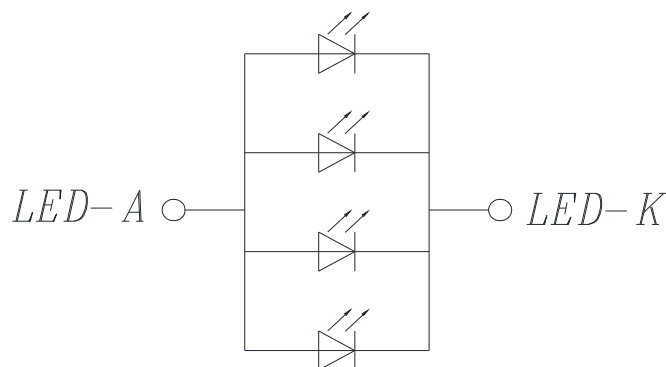

CIRCUIT DIAGRAM

# *DEM 480480J VMH-PW-N(C-TOUCH) Product Specification*

Note (3) Luminance Uniformity of these 9 points is defined as below:

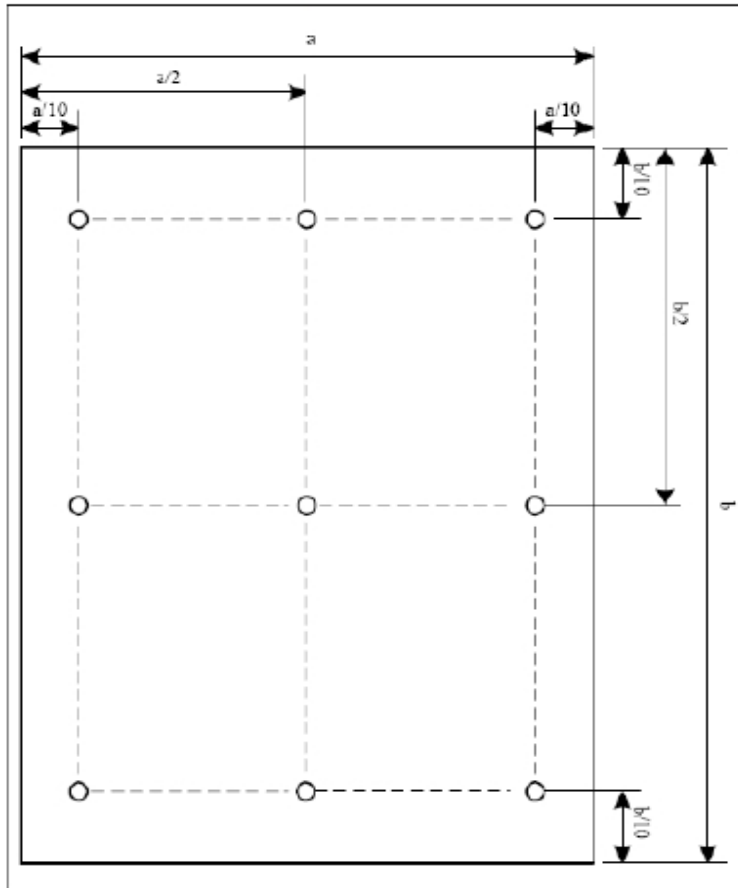

$$\text{Uniformity} = \frac{\text{minimum luminance in 9 points (1-9)}}{\text{maximum luminance in 9 points (1-9)}}$$

$$\text{Luminance} = \frac{\text{Total Luminance of 9 points}}{9}$$

## 7. AC Characteristics

### 7.1 MIPI Interface Characteristics:

#### 7.1.1 High Speed Mode



\*DSI clock channel timing

| Signal     | Symbol                       | Parameter                | MIN  | MAX  | Unit | Description                    |
|------------|------------------------------|--------------------------|------|------|------|--------------------------------|
| DSI-CLK+/- | $2xUI_{INSTA}$               | Double UI instantaneous  | 4    | 25   | ns   |                                |
| DSI-CLK+/- | $UI_{INSTA}$<br>$UI_{INSTB}$ | UI instantaneous halves  | 2    | 12.5 | ns   | $UI = UI_{INSTA} = UI_{INSTB}$ |
| DSI-Dn+/-  | $t_{DS}$                     | Data to clock setup time | 0.15 | -    | UI   |                                |
| DSI-Dn+/-  | $t_{DH}$                     | Data to clock hold time  | 0.15 | -    | UI   |                                |

\* MIPI Interface-High SpeedMode Timing Characteristics



## 7.1.2 Low Power Mode

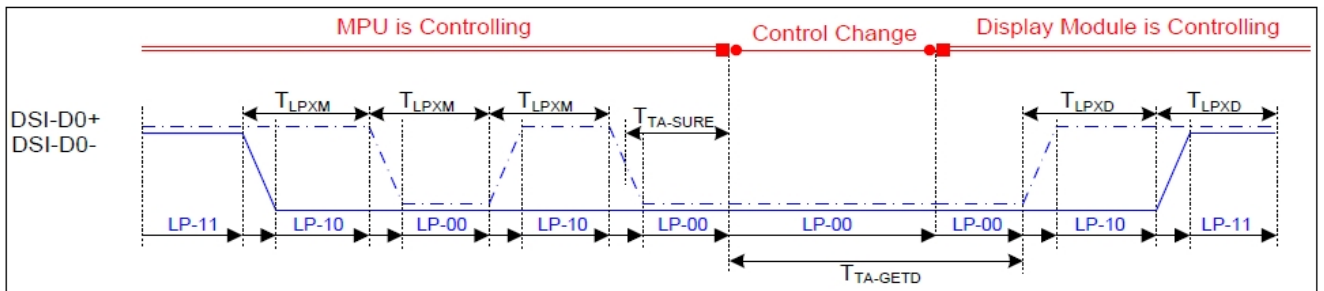

**\* Bus Turnaround (BTA) from display module to MPU Timing**

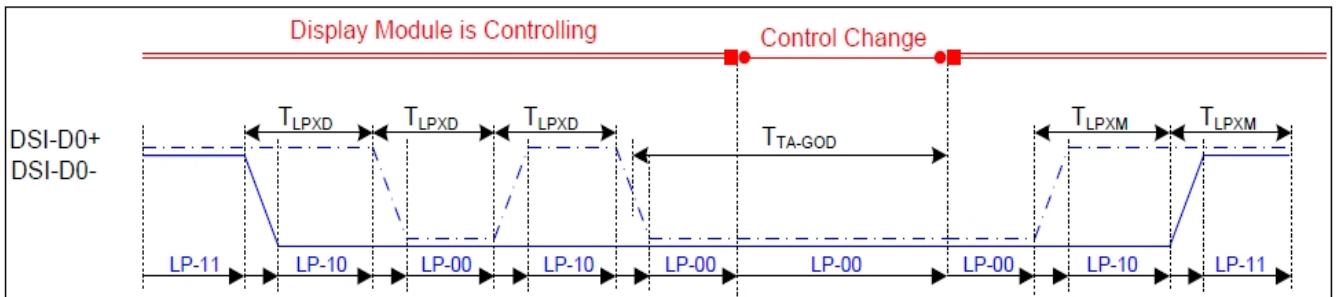

**\*Bus Turnaround (BTA) from MPU to display module Timing**

| Signal    | Symbol    | Parameter   | MIN                 | MAX                 | Unit | Description |
|-----------|-----------|---|---------------------|---------------------|------|-------------|
| DSI-D0+/- | TLPXM     | Length of LP-00,LP-01, LP-10 or LP-11 periods<br>MPU→Display Module | 50                  | 75                  | ns   | Input       |
| DSI-D0+/- | TLPXD     | Length of LP-00,LP-01, LP-10 or LP-11 periods<br>MPU→Display Module | 50                  | 75                  | ns   | Output      |
| DSI-D0+/- | TTA-SURED | Time-out before the MPU start driving                               | $T_{LPXD}$          | $2 \times T_{LPXD}$ | ns   | Output      |
| DSI-D0+/- | TTA-GETD  | Time to drive LP-00 by display module                               | $5 \times T_{LPXD}$ |                     | ns   | Input       |
| DSI-D0+/- | TTA-GOD   | Time to drive LP-00 after turnaround request-MPU                    | $4 \times T_{LPXD}$ |                     | ns   | Output      |

**\*MIPI Interface Low Power Mode Timing Characteristics**

## 7.1.3 Burst Mode

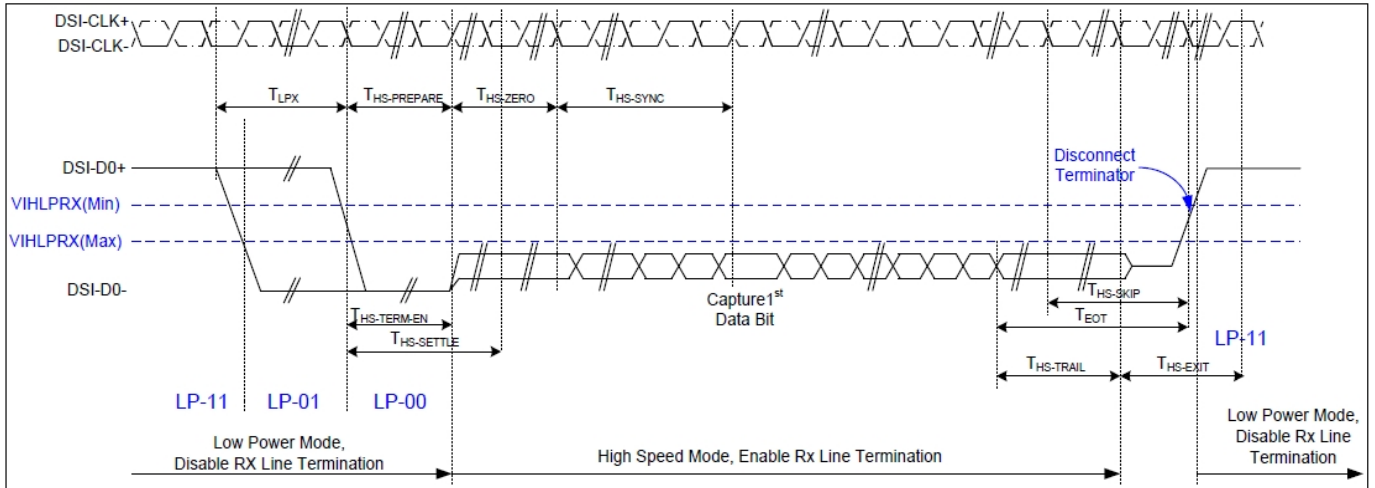

**\*Data lanes-Low Power Mode to/from High Speed Mode Timing**

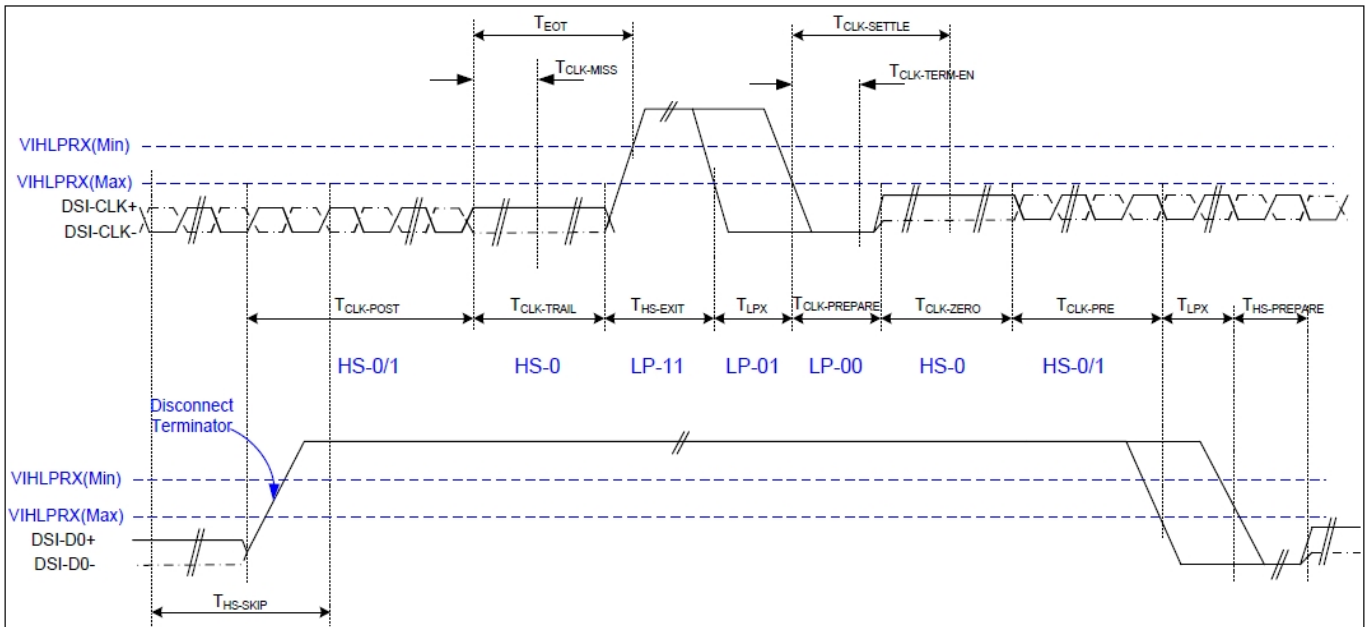

**\*Clock lanes- High Speed Mode to/from Low Power Mode Timing**

# DEM 480480J VMH-PW-N(C-TOUCH) Product Specification

| Signal  | Symbol                   | Parameter  | MIN          | MAX                | Unit | Description |
|---|--------------------------|--|--------------|--------------------|------|-------------|
| Low Power Mode to High Speed Mode Timing      |                          |  |              |                    |      |             |
| DSI-Dn+/-                                     | TLPX                     | Length of any low power state period   | 50           | -                  | ns   | Input       |
| DSI-Dn+/-                                     | THS-PREPARE              | Time to drive LP-00 to prepare for HS transmission   | 40+4<br>UI   | 85+8<br>UI         | ns   | Input       |
| DSI-Dn+/-                                     | THS-TERM-EN              | Time to enable data receiver line termination measured from when Dn crosses VILMAX                                   | -            | 35+4<br>UI         | ns   | Input       |
| DSI-Dn+/-                                     | THS-PREPARE + THS-ZERO   | THS-PREPARE + time to drive HS-0 before the sync sequence  | 140+<br>10UI | -                  | ns   | Input       |
| High Speed Mode to Low Power Mode Timing      |                          |  |              |                    |      |             |
| DSI-Dn+/-                                     | THS-SKIP                 | Time-out at display module to ignore transition period of EoT  | 40           | 55+4<br>UI         | ns   | Input       |
| DSI-Dn+/-                                     | THS-EXIT                 | Time to drive LP-11 after HS burst   | 100          | -                  | ns   | Input       |
| DSI-Dn+/-                                     | THS-TRAIL                | Time to drive flipped differential state after last payload data bit of a HS transmission burst                      | 60+4<br>UI   | -                  | ns   | Input       |
| High Speed Mode to/from Low Power Mode Timing |                          |  |              |                    |      |             |
| DSI-CLK+/-                                    | TCLK-POS                 | Time that the MPU shall continue sending HS clock after the last associated data lane has transition to LP mode      | 60+5<br>2UI  | -                  | ns   | Input       |
| DSI-CLK+/-                                    | TCLK-TRAIL               | Time to drive HS differential state after last payload clock bit of a HS transmission burst                          | 60           | -                  | ns   | Input       |
| DSI-CLK+/-                                    | THS-EXIT                 | Time to drive LP-11 after HS burst   | 100          | -                  | ns   | Input       |
| DSI-CLK+/-                                    | TCLK-PREPARE             | Time to drive LP-00 to prepare for HS transmission   | 38           | 95                 | ns   | Input       |
| DSI-CLK+/-                                    | TCLK-TERM-EN             | Time-out at clock lan display module to enable HS transmission   | --           | 38                 | ns   | Input       |
| DSI-CLK+/-                                    | TCLK-PREPARE + TCLK-ZERO | Minimum lead HS-0 drive period before starting clock   | 300          | -                  | ns   | Input       |
| DSI-CLK+/-                                    | TCLK-PRE                 | Time that the HS clock shall be driven prior to any associated data lane beginning the transition from LP to HS mode | 8UI          | -                  | ns   | Input       |
| DSI-CLK+/-                                    | TEOT                     | Time form start of TCLK-TRAIL period to start of LP-11 state   | -            | 105n<br>s+12<br>UI | ns   | Input       |

## 7.2 Reset Timing

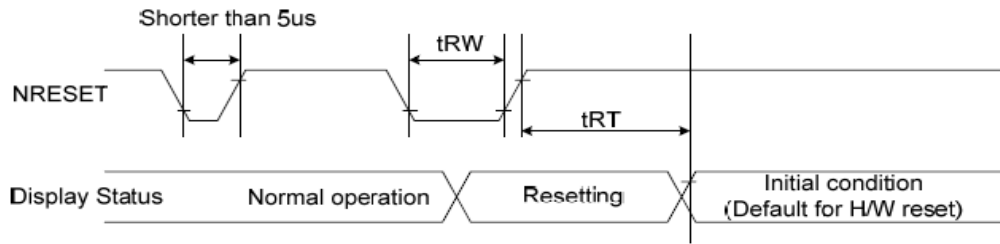

**Figure 102 Reset Timing**

**Table 41 Reset Timing**

| Signal | Symbol | Parameter            | Min | Max                             | Unit |
|--------|--------|----------------------|-----|---------------------------------|------|
| RESX   | tRW    | Reset pulse duration | 10  |                                 | us   |
|        | tRT    | Reset cancel         |     | 5(note 1,5)<br>120 (note 1,6,7) | ms   |

Note:

- The reset cancel includes also required time for loading ID bytes, VCOM setting and other settings from OTP to registers. This loading is done every time when there is H/W reset cancel time (tRT) within 5 ms after a rising edge of RESX.
- Spike due to an electrostatic discharge on RESX line does not cause irregular system reset according to the Table 43.

**Table 42 Reset Descript**

| RESX Pulse          | Action         |
|---------------------|----------------|
| Shorter than 5us    | Reset Rejected |
| Longer than 9us     | Reset          |
| Between 5us and 9us | Reset starts   |

- During the Resetting period, the display will be blanked (The display is entering blanking sequence, which maximum time is 120 ms, when Reset Starts in Sleep Out mode. The display remains the blank state in Sleep In mode.) and then return to Default condition for Hardware Reset.
- Spike Rejection also applies during a valid reset pulse as shown below:

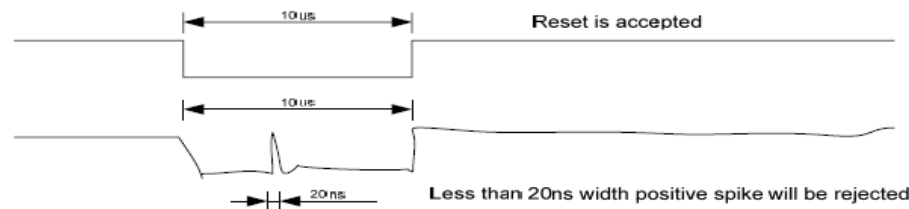

**Figure 103 Positive Noise Pulse during Reset Low**

- When Reset applied during Sleep In Mode.
- When Reset applied during Sleep Out Mode.
- It is necessary to wait 5msec after releasing RESX before sending commands. Also Sleep Out command cannot be sent for 120msec.

## 8. CTP Specification

### 8.1 Electrical Characteristics

#### 8.1.1 Absolute Maximum Rating

| Item                  | Symbol          | Min. | Max. | Unit | Note |
|-----------------------|-----------------|------|------|------|------|
| Power Supply Voltage  | VDD             | -0.3 | 6    | V    | -    |
| Operating Temperature | T <sub>OP</sub> | -20  | +70  | °C   | -    |
| Storage Temperature   | T <sub>ST</sub> | -30  | +80  | °C   | -    |

\*Note: Stresses above those listed under "Absolute Maximum Ratings" may cause permanent damage to the device. All the ranges are stress ratings only. Functional operation of this device at these or any other conditions above those indicated in the operational sections of this specification is not implied or intended.

Exposed to the absolute maximum rating conditions for extended periods may affect device reliability.

#### 8.1.2 DC Electrical Characteristics (Ta=25°C)

(Ambient temperature: 25°C, VDD=3.3V, VDDIO=1.8V or VDDIO=VDD)

| Item                           | Min.     | Typ. | Max.     | Unit | Note |
|--------------------------------|----------|------|----------|------|------|
| Power Supply Voltage/VDD       | 2.7      | 3.3  | 3.6      | V    | --   |
| Normal mode operating current  | --       | 16.1 | 24       | mA   | --   |
| Green mode operating current   | --       | 8.1  | 12.2     | mA   | --   |
| Power Down Current             | --       | --   | 20       | uA   | --   |
| Digital Input low voltage/VIL  | --       | --   | 0.15*VDD | V    | --   |
| Digital Input high voltage/VIH | 0.85*VDD | --   | --       | V    | --   |

## 8.2 AC Electrical Characteristics

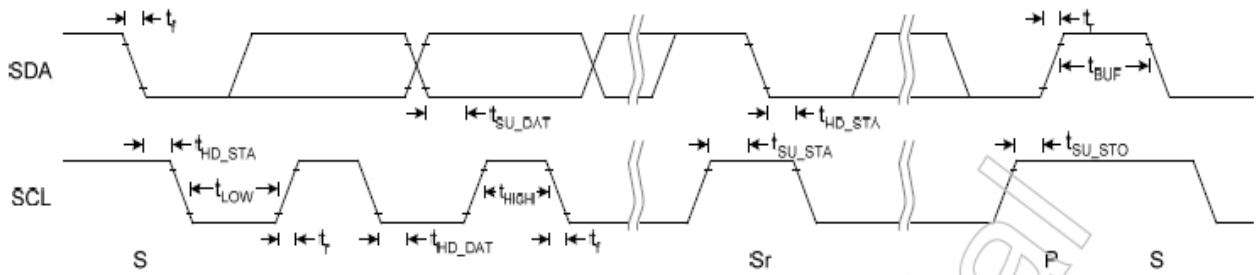

Figure 5-1 I2C Fast Mode Timing

Table 5-3 I2C Fast Mode Timing Characteristic

Conditions: VDD = 3.3V, GND = 0V, T<sub>A</sub> = 25°C

| Symbol              | Parameter   | Rating |     |      | Unit |
|---------------------|---|--------|-----|------|------|
|                     |   | Min.   | Typ | Max. |      |
| f <sub>SCL</sub>    | SCL clock frequency   | 0      | -   | 400  | kHz  |
| t <sub>LOW</sub>    | Low period of the SCL clock   | 1.3    | -   | -    | us   |
| t <sub>HIGH</sub>   | High period of the SCL clock  | 0.6    | -   | -    | us   |
| t <sub>f</sub>      | Signal falling time   | -      | -   | 300  | ns   |
| t <sub>r</sub>      | Signal rising time  | -      | -   | 300  | ns   |
| t <sub>SU_STA</sub> | Set up time for a repeated START condition  | 0.6    | -   | -    | us   |
| t <sub>HD_STA</sub> | Hold time (repeated) START condition. After this period, the first clock pulse is generated | 0.6    | -   | -    | us   |
| t <sub>SU_DAT</sub> | Data set up time  | 100    | -   | -    | ns   |
| t <sub>HD_DAT</sub> | Data hold time  | 0      | -   | 0.9  | us   |
| t <sub>SU_STO</sub> | Set up time for STOP condition  | 0.6    | -   | -    | us   |
| t <sub>BUF</sub>    | Bus free time between a STOP and START condition  | 1.3    | -   | -    | us   |
| C <sub>b</sub>      | Capacitive load for each bus line   | -      | -   | 400  | pF   |

## 8.3 SYSTEM MANAGEMENT

### 8.3.1 Power Down

In power down mode, all of the clocks of ST1633i are stopped. The way to exit power down mode is by a hardware reset or I2C.

### 8.3.2 Reset

Master can reset ST1633i through RESET pin. RESET pin is low active and needs hold low for 1us to take effect.

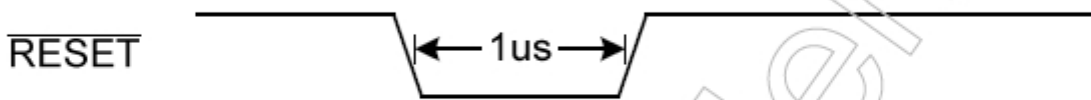

Figure 3-1  $\overline{\text{RESET}}$  Pin Low Pulse Width

### 8.3.3 Power On/Off Sequence

RESET pin should be held low before power on and power off. During power on, after both VDD and IOVDD reach normal voltage, RESET pin needs to be held low for 5ms to ensure internal block stable.

Note: IOVDD and VDD had connected together.

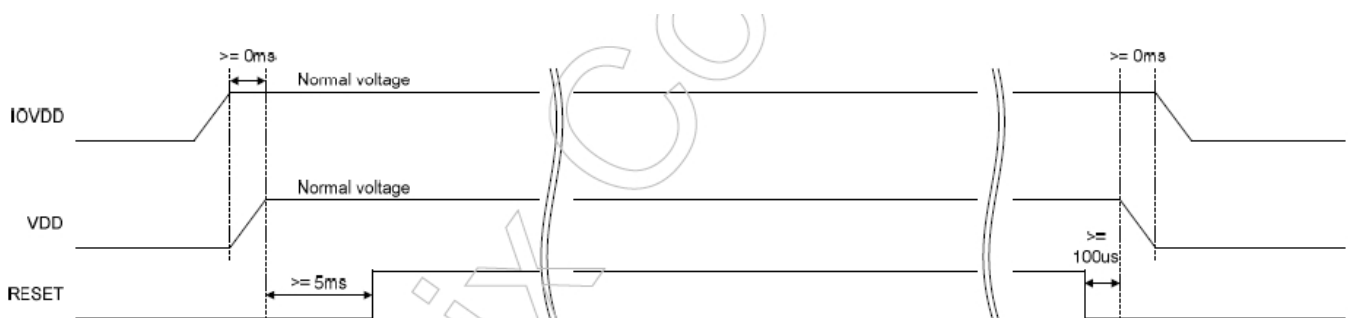

Figure 3-2 Power On/Off Sequence

## 9. LCD Module Out-Going Quality Level

### 9.1 VISUAL & FUNCTION INSPECTION STANDARD

#### 9.1.1 Inspection Conditions

Inspection performed under the following conditions is recommended.

Temperature:  $25^{\circ}\text{C}\pm 5^{\circ}\text{C}$

Humidity:  $65\%\pm 10\%\text{RH}$

Viewing Angle: Normal viewing Angle.

Illumination: Single fluorescent lamp (300 to 700Lux)

Viewing distance: 30-50cm

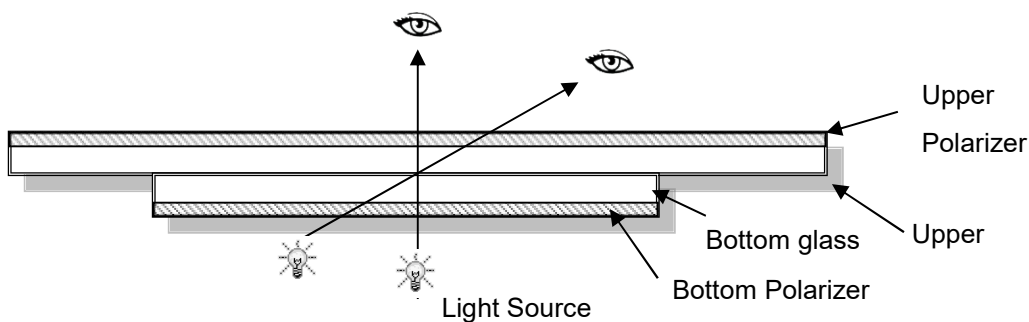

#### 9.1.2 Definition

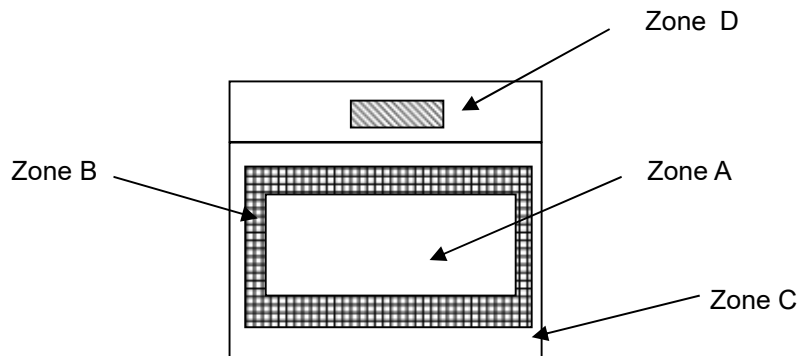

Zone A : Effective Viewing Area(Character or Digit can be seen)

Zone B : Viewing Area except Zone A

Zone C : Outside (Zone A+Zone B) which can not be seen after assembly by customer

Zone D : IC Bonding Area

Note: As a general rule ,visual defects in Zone C can be ignored when it doesn't effect product function or appearance after assembly by customer



# DEM 480480J VMH-PW-N(C-TOUCH) Product Specification

## 9.1.3 Sampling Plan

According to GB/T 2828-2012, normal inspection, Class II

AQL:

| Major Defect | Minor Defect |
|--------------|--------------|
| 0.65         | 1.5          |

LCD: Liquid Crystal Display, LCM: Liquid Crystal Module, CTP: Capacitive Touch Panel

| No | Items to be inspected | Criteria  | Classification of defects |
|----|-----------------------|---|---------------------------|
| 1  | Functional defects    | 1) No display, Open or miss line<br>2) Display abnormally, Short<br>3) Backlight no lighting, abnormal lighting.<br>etc | Major                     |
| 2  | Missing               | Missing components and etc  |                           |
| 3  | Outline dimension     | Overall outline dimension beyond the drawing is not allowed, deformation and etc  |                           |
| 4  | Color tone            | Color unevenness, refer to limited sample   | Minor                     |
| 5  | Spot/Line defect      | Light dot, Dim spot, (Note1)<br>Polarizer Air Bubble,<br>Polarizer accidented spot and etc.                             |                           |
| 6  | Soldering appearance  | Good soldering , Peeling off is not allowed and etc.  |                           |
| 7  | LCD/Polarizer/CTP     | Black/White spot/line, scratch, crack, etc.   |                           |

Note1: a) Light dot: Dots appear bright and unchanged in size in which LCD panel is displaying under black pattern.

b) Dim dot: Dots appear dark and unchanged in size in which LCD panel is displaying under pure red, green, blue picture.

# DEM 480480J VMH-PW-N(C-TOUCH) Product Specification

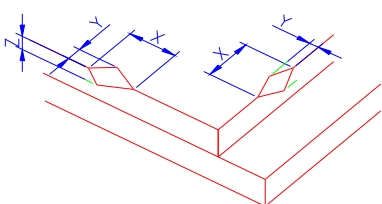
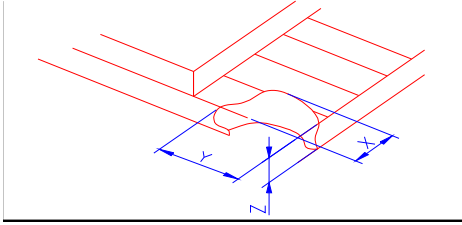
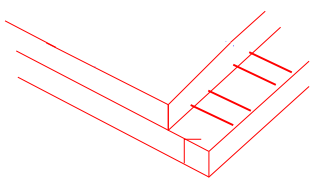

## 9.1.4 Criteria (Visual)

| Number  | Items  | Criteria(mm)  |    |   |        |        |                                |    |
|---|--|---|----|---|--------|--------|--------------------------------|----|
| 1.0 LCD<br>Crack/Broken<br>NOTE:<br>X: Length<br>Y: Width<br>Z: Height<br>L: Length of ITO,<br>T: Height of LCD | (1) The edge of LCD broken   |  <table border="1" style="margin: 10px auto; border-collapse: collapse;"> <thead> <tr style="background-color: #cccccc;"> <th style="width: 30%;">X</th> <th style="width: 40%;">Y</th> <th style="width: 30%;">Z</th> </tr> </thead> <tbody> <tr> <td style="text-align: center;">≤3.0mm</td> <td style="text-align: center;">&lt;Inner border line of the seal</td> <td style="text-align: center;">≤T</td> </tr> </tbody> </table> | X  | Y | Z      | ≤3.0mm | <Inner border line of the seal | ≤T |
|   | X  | Y   | Z  |   |        |        |                                |    |
|   | ≤3.0mm   | <Inner border line of the seal  | ≤T |   |        |        |                                |    |
| (2) LCD corner broken   |  <table border="1" style="margin: 10px auto; border-collapse: collapse;"> <thead> <tr style="background-color: #cccccc;"> <th style="width: 30%;">X</th> <th style="width: 30%;">Y</th> <th style="width: 40%;">Z</th> </tr> </thead> <tbody> <tr> <td style="text-align: center;">≤3.0mm</td> <td style="text-align: center;">≤L</td> <td style="text-align: center;">≤T</td> </tr> </tbody> </table> | X   | Y  | Z | ≤3.0mm | ≤L     | ≤T                             |    |
| X   | Y  | Z   |    |   |        |        |                                |    |
| ≤3.0mm  | ≤L   | ≤T  |    |   |        |        |                                |    |
| (3) LCD crack   |  <p style="text-align: center; margin-top: 10px;">Crack<br/>Not allowed</p>  |   |    |   |        |        |                                |    |

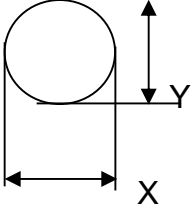
# DEM 480480J VMH-PW-N(C-TOUCH) Product Specification

| 2.0                     | Spot defect   | ① light dot ( black/white spot , pinhole, stain, etc. )   |   |                   |                   |                |  |   |   |   |                  |                  |        |  |                         |                          |                          |  |                        |                          |                          |  |              |              |   |  |  |
|-------------------------|---|---|---|-------------------|-------------------|----------------|--|---|---|---|------------------|------------------|--------|--|-------------------------|--------------------------|--------------------------|--|------------------------|--------------------------|--------------------------|--|--------------|--------------|---|--|--|
|                         |    | <table border="1"> <thead> <tr> <th rowspan="2">Zone<br/>Size (mm)</th> <th colspan="3">Acceptable Qty</th> </tr> <tr> <th>A</th> <th>B</th> <th>C</th> </tr> </thead> <tbody> <tr> <td><math>\Phi \leq 0.15</math></td> <td colspan="3">Ignore</td> </tr> <tr> <td><math>0.15 &lt; \Phi \leq 0.25</math></td> <td colspan="3">3(distance <math>\geq 6</math>mm)</td> </tr> <tr> <td><math>0.25 &lt; \Phi \leq 0.4</math></td> <td colspan="3">2(distance <math>\geq 6</math>mm)</td> </tr> <tr> <td><math>\Phi &gt; 0.4</math></td> <td colspan="3">0</td> </tr> </tbody> </table>   |   |                   | Zone<br>Size (mm) | Acceptable Qty |  |   | A | B | C                | $\Phi \leq 0.15$ | Ignore |  |                         | $0.15 < \Phi \leq 0.25$  | 3(distance $\geq 6$ mm)  |  |                        | $0.25 < \Phi \leq 0.4$   | 2(distance $\geq 6$ mm)  |  |              | $\Phi > 0.4$ | 0 |  |  |
|                         | Zone<br>Size (mm)   | Acceptable Qty  |   |                   |                   |                |  |   |   |   |                  |                  |        |  |                         |                          |                          |  |                        |                          |                          |  |              |              |   |  |  |
|                         |   | A   | B | C                 |                   |                |  |   |   |   |                  |                  |        |  |                         |                          |                          |  |                        |                          |                          |  |              |              |   |  |  |
| $\Phi \leq 0.15$        | Ignore  |   |   |                   |                   |                |  |   |   |   |                  |                  |        |  |                         |                          |                          |  |                        |                          |                          |  |              |              |   |  |  |
| $0.15 < \Phi \leq 0.25$ | 3(distance $\geq 6$ mm)   |   |   |                   |                   |                |  |   |   |   |                  |                  |        |  |                         |                          |                          |  |                        |                          |                          |  |              |              |   |  |  |
| $0.25 < \Phi \leq 0.4$  | 2(distance $\geq 6$ mm)   |   |   |                   |                   |                |  |   |   |   |                  |                  |        |  |                         |                          |                          |  |                        |                          |                          |  |              |              |   |  |  |
| $\Phi > 0.4$            | 0   |   |   |                   |                   |                |  |   |   |   |                  |                  |        |  |                         |                          |                          |  |                        |                          |                          |  |              |              |   |  |  |
| $\Phi = (X+Y)/2$        | <table border="1"> <thead> <tr> <th rowspan="2">Zone<br/>Size (mm)</th> <th colspan="3">Acceptable Qty</th> </tr> <tr> <th>A</th> <th>B</th> <th>C</th> </tr> </thead> <tbody> <tr> <td><math>\Phi \leq 0.15</math></td> <td colspan="3">Ignore</td> </tr> <tr> <td><math>0.15 &lt; \Phi \leq 0.25</math></td> <td colspan="3">3( distance <math>\geq 6</math>mm)</td> </tr> <tr> <td><math>0.25 &lt; \Phi \leq 0.4</math></td> <td colspan="3">2( distance <math>\geq 6</math>mm)</td> </tr> <tr> <td><math>\Phi &gt; 0.4</math></td> <td colspan="3">0</td> </tr> </tbody> </table> |   |   | Zone<br>Size (mm) | Acceptable Qty    |                |  | A | B | C | $\Phi \leq 0.15$ | Ignore           |        |  | $0.15 < \Phi \leq 0.25$ | 3( distance $\geq 6$ mm) |                          |  | $0.25 < \Phi \leq 0.4$ | 2( distance $\geq 6$ mm) |                          |  | $\Phi > 0.4$ | 0            |   |  |  |
| Zone<br>Size (mm)       | Acceptable Qty  |   |   |                   |                   |                |  |   |   |   |                  |                  |        |  |                         |                          |                          |  |                        |                          |                          |  |              |              |   |  |  |
|                         | A   | B   | C |                   |                   |                |  |   |   |   |                  |                  |        |  |                         |                          |                          |  |                        |                          |                          |  |              |              |   |  |  |
| $\Phi \leq 0.15$        | Ignore  |   |   |                   |                   |                |  |   |   |   |                  |                  |        |  |                         |                          |                          |  |                        |                          |                          |  |              |              |   |  |  |
| $0.15 < \Phi \leq 0.25$ | 3( distance $\geq 6$ mm)  |   |   |                   |                   |                |  |   |   |   |                  |                  |        |  |                         |                          |                          |  |                        |                          |                          |  |              |              |   |  |  |
| $0.25 < \Phi \leq 0.4$  | 2( distance $\geq 6$ mm)  |   |   |                   |                   |                |  |   |   |   |                  |                  |        |  |                         |                          |                          |  |                        |                          |                          |  |              |              |   |  |  |
| $\Phi > 0.4$            | 0   |   |   |                   |                   |                |  |   |   |   |                  |                  |        |  |                         |                          |                          |  |                        |                          |                          |  |              |              |   |  |  |
|                         |   | ② Dim spot ( light leakage、dent、dark spot, etc )  |   |                   |                   |                |  |   |   |   |                  |                  |        |  |                         |                          |                          |  |                        |                          |                          |  |              |              |   |  |  |
|                         |   | <table border="1"> <thead> <tr> <th rowspan="2">Zone<br/>Size (mm)</th> <th colspan="3">Acceptable Qty</th> </tr> <tr> <th>A</th> <th>B</th> <th>C</th> </tr> </thead> <tbody> <tr> <td><math>\Phi \leq 0.15</math></td> <td colspan="3">Ignore</td> </tr> <tr> <td><math>0.15 &lt; \Phi \leq 0.25</math></td> <td colspan="3">3( distance <math>\geq 6</math>mm)</td> </tr> <tr> <td><math>0.25 &lt; \Phi \leq 0.4</math></td> <td colspan="3">2( distance <math>\geq 6</math>mm)</td> </tr> <tr> <td><math>\Phi &gt; 0.4</math></td> <td colspan="3">0</td> </tr> </tbody> </table> |   |                   | Zone<br>Size (mm) | Acceptable Qty |  |   | A | B | C                | $\Phi \leq 0.15$ | Ignore |  |                         | $0.15 < \Phi \leq 0.25$  | 3( distance $\geq 6$ mm) |  |                        | $0.25 < \Phi \leq 0.4$   | 2( distance $\geq 6$ mm) |  |              | $\Phi > 0.4$ | 0 |  |  |
| Zone<br>Size (mm)       | Acceptable Qty  |   |   |                   |                   |                |  |   |   |   |                  |                  |        |  |                         |                          |                          |  |                        |                          |                          |  |              |              |   |  |  |
|                         | A   | B   | C |                   |                   |                |  |   |   |   |                  |                  |        |  |                         |                          |                          |  |                        |                          |                          |  |              |              |   |  |  |
| $\Phi \leq 0.15$        | Ignore  |   |   |                   |                   |                |  |   |   |   |                  |                  |        |  |                         |                          |                          |  |                        |                          |                          |  |              |              |   |  |  |
| $0.15 < \Phi \leq 0.25$ | 3( distance $\geq 6$ mm)  |   |   |                   |                   |                |  |   |   |   |                  |                  |        |  |                         |                          |                          |  |                        |                          |                          |  |              |              |   |  |  |
| $0.25 < \Phi \leq 0.4$  | 2( distance $\geq 6$ mm)  |   |   |                   |                   |                |  |   |   |   |                  |                  |        |  |                         |                          |                          |  |                        |                          |                          |  |              |              |   |  |  |
| $\Phi > 0.4$            | 0   |   |   |                   |                   |                |  |   |   |   |                  |                  |        |  |                         |                          |                          |  |                        |                          |                          |  |              |              |   |  |  |
|                         |   | ③ Polarizer accidented spot   |   |                   |                   |                |  |   |   |   |                  |                  |        |  |                         |                          |                          |  |                        |                          |                          |  |              |              |   |  |  |
|                         |   | <table border="1"> <thead> <tr> <th rowspan="2">Zone<br/>Size (mm)</th> <th colspan="3">Acceptable Qty</th> </tr> <tr> <th>A</th> <th>B</th> <th>C</th> </tr> </thead> <tbody> <tr> <td><math>\Phi \leq 0.2</math></td> <td colspan="3">Ignore</td> </tr> <tr> <td><math>0.2 &lt; \Phi \leq 0.5</math></td> <td colspan="3">2( distance <math>\geq 6</math>mm)</td> </tr> <tr> <td><math>\Phi &gt; 0.5</math></td> <td colspan="3">0</td> </tr> </tbody> </table>   |   |                   | Zone<br>Size (mm) | Acceptable Qty |  |   | A | B | C                | $\Phi \leq 0.2$  | Ignore |  |                         | $0.2 < \Phi \leq 0.5$    | 2( distance $\geq 6$ mm) |  |                        | $\Phi > 0.5$             | 0                        |  |              |              |   |  |  |
| Zone<br>Size (mm)       | Acceptable Qty  |   |   |                   |                   |                |  |   |   |   |                  |                  |        |  |                         |                          |                          |  |                        |                          |                          |  |              |              |   |  |  |
|                         | A   | B   | C |                   |                   |                |  |   |   |   |                  |                  |        |  |                         |                          |                          |  |                        |                          |                          |  |              |              |   |  |  |
| $\Phi \leq 0.2$         | Ignore  |   |   |                   |                   |                |  |   |   |   |                  |                  |        |  |                         |                          |                          |  |                        |                          |                          |  |              |              |   |  |  |
| $0.2 < \Phi \leq 0.5$   | 2( distance $\geq 6$ mm)  |   |   |                   |                   |                |  |   |   |   |                  |                  |        |  |                         |                          |                          |  |                        |                          |                          |  |              |              |   |  |  |
| $\Phi > 0.5$            | 0   |   |   |                   |                   |                |  |   |   |   |                  |                  |        |  |                         |                          |                          |  |                        |                          |                          |  |              |              |   |  |  |
|                         |   | ④ Polarizer Bubble  |   |                   |                   |                |  |   |   |   |                  |                  |        |  |                         |                          |                          |  |                        |                          |                          |  |              |              |   |  |  |
|                         |   | <table border="1"> <thead> <tr> <th rowspan="2">Zone<br/>Size (mm)</th> <th colspan="3">Acceptable Qty</th> </tr> <tr> <th>A</th> <th>B</th> <th>C</th> </tr> </thead> <tbody> <tr> <td><math>\Phi \leq 0.2</math></td> <td colspan="3">Ignore</td> </tr> <tr> <td><math>0.2 &lt; \Phi \leq 0.4</math></td> <td colspan="3">3(distance <math>\geq 6</math>mm)</td> </tr> <tr> <td><math>\Phi &gt; 0.4</math></td> <td colspan="3">0</td> </tr> </tbody> </table>  |   |                   | Zone<br>Size (mm) | Acceptable Qty |  |   | A | B | C                | $\Phi \leq 0.2$  | Ignore |  |                         | $0.2 < \Phi \leq 0.4$    | 3(distance $\geq 6$ mm)  |  |                        | $\Phi > 0.4$             | 0                        |  |              |              |   |  |  |
| Zone<br>Size (mm)       | Acceptable Qty  |   |   |                   |                   |                |  |   |   |   |                  |                  |        |  |                         |                          |                          |  |                        |                          |                          |  |              |              |   |  |  |
|                         | A   | B   | C |                   |                   |                |  |   |   |   |                  |                  |        |  |                         |                          |                          |  |                        |                          |                          |  |              |              |   |  |  |
| $\Phi \leq 0.2$         | Ignore  |   |   |                   |                   |                |  |   |   |   |                  |                  |        |  |                         |                          |                          |  |                        |                          |                          |  |              |              |   |  |  |
| $0.2 < \Phi \leq 0.4$   | 3(distance $\geq 6$ mm)   |   |   |                   |                   |                |  |   |   |   |                  |                  |        |  |                         |                          |                          |  |                        |                          |                          |  |              |              |   |  |  |
| $\Phi > 0.4$            | 0   |   |   |                   |                   |                |  |   |   |   |                  |                  |        |  |                         |                          |                          |  |                        |                          |                          |  |              |              |   |  |  |

# DEM 480480J VMH-PW-N(C-TOUCH) Product Specification

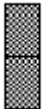
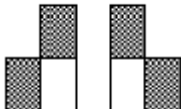
| 3.0        | LCD Pixel defect  | Pixel bad points   |      |        |                |            |        |            |                 |            |                 |            |          |        |            |                 |            |                 |            |          |   |     |  |  |                           |  |  |            |
|------------|---|--|------|--------|----------------|------------|--------|------------|-----------------|------------|-----------------|------------|----------|--------|------------|-----------------|------------|-----------------|------------|----------|---|-----|--|--|---------------------------|--|--|------------|
|            |   | <table border="1" style="width: 100%; border-collapse: collapse;"> <thead> <tr style="background-color: #cccccc;"> <th style="width: 20%;">Item</th> <th style="width: 50%;">Zone A</th> <th style="width: 30%;">Acceptable Qty</th> </tr> </thead> <tbody> <tr> <td rowspan="3" style="text-align: center;">Bright dot</td> <td>Random</td> <td style="text-align: center;"><math>N \leq 2</math></td> </tr> <tr> <td>2 dots adjacent</td> <td style="text-align: center;"><math>N \leq 0</math></td> </tr> <tr> <td>3 dots adjacent</td> <td style="text-align: center;"><math>N \leq 0</math></td> </tr> <tr> <td rowspan="3" style="text-align: center;">Dark dot</td> <td>Random</td> <td style="text-align: center;"><math>N \leq 2</math></td> </tr> <tr> <td>2 dots adjacent</td> <td style="text-align: center;"><math>N \leq 0</math></td> </tr> <tr> <td>3 dots adjacent</td> <td style="text-align: center;"><math>N \leq 0</math></td> </tr> <tr> <td style="text-align: center;">Distance</td> <td>                     1. Minimum Distance Between Bright dots.<br/>                     2. Minimum Distance Between dark dots<br/>                     3. Minimum Distance Between dark and bright dot.                 </td> <td style="text-align: center; vertical-align: middle;">5mm</td> </tr> <tr> <td colspan="2"></td> <td style="text-align: center;">Total bright and dark dot</td> </tr> <tr> <td colspan="2"></td> <td style="text-align: center;"><math>N \leq 4</math></td> </tr> </tbody> </table> | Item | Zone A | Acceptable Qty | Bright dot | Random | $N \leq 2$ | 2 dots adjacent | $N \leq 0$ | 3 dots adjacent | $N \leq 0$ | Dark dot | Random | $N \leq 2$ | 2 dots adjacent | $N \leq 0$ | 3 dots adjacent | $N \leq 0$ | Distance | 1. Minimum Distance Between Bright dots.<br>2. Minimum Distance Between dark dots<br>3. Minimum Distance Between dark and bright dot. | 5mm |  |  | Total bright and dark dot |  |  | $N \leq 4$ |
| Item       | Zone A  | Acceptable Qty   |      |        |                |            |        |            |                 |            |                 |            |          |        |            |                 |            |                 |            |          |   |     |  |  |                           |  |  |            |
| Bright dot | Random  | $N \leq 2$   |      |        |                |            |        |            |                 |            |                 |            |          |        |            |                 |            |                 |            |          |   |     |  |  |                           |  |  |            |
|            | 2 dots adjacent   | $N \leq 0$   |      |        |                |            |        |            |                 |            |                 |            |          |        |            |                 |            |                 |            |          |   |     |  |  |                           |  |  |            |
|            | 3 dots adjacent   | $N \leq 0$   |      |        |                |            |        |            |                 |            |                 |            |          |        |            |                 |            |                 |            |          |   |     |  |  |                           |  |  |            |
| Dark dot   | Random  | $N \leq 2$   |      |        |                |            |        |            |                 |            |                 |            |          |        |            |                 |            |                 |            |          |   |     |  |  |                           |  |  |            |
|            | 2 dots adjacent   | $N \leq 0$   |      |        |                |            |        |            |                 |            |                 |            |          |        |            |                 |            |                 |            |          |   |     |  |  |                           |  |  |            |
|            | 3 dots adjacent   | $N \leq 0$   |      |        |                |            |        |            |                 |            |                 |            |          |        |            |                 |            |                 |            |          |   |     |  |  |                           |  |  |            |
| Distance   | 1. Minimum Distance Between Bright dots.<br>2. Minimum Distance Between dark dots<br>3. Minimum Distance Between dark and bright dot. | 5mm  |      |        |                |            |        |            |                 |            |                 |            |          |        |            |                 |            |                 |            |          |   |     |  |  |                           |  |  |            |
|            |   | Total bright and dark dot  |      |        |                |            |        |            |                 |            |                 |            |          |        |            |                 |            |                 |            |          |   |     |  |  |                           |  |  |            |
|            |   | $N \leq 4$   |      |        |                |            |        |            |                 |            |                 |            |          |        |            |                 |            |                 |            |          |   |     |  |  |                           |  |  |            |
|            |   | <p>Note:</p> <p>A) Bright dot: Dots appear bright and unchanged in size in which LCD panel is displaying under black pattern.</p> <p>B) Dark dot: Dots appear dark and unchanged in size in which LCD panel is displaying under pure red, green, blue picture.</p> <p>C) 2 dot adjacent = 1 pair = 2 dots</p> <p>Picture:</p> <div style="display: flex; justify-content: space-around; align-items: flex-start;"> <div style="text-align: center;">  <p>2 dot adjacent</p> </div> <div style="text-align: center;">  <p>2 dot adjacent</p> </div> </div> <div style="display: flex; justify-content: space-around; align-items: flex-start; margin-top: 20px;"> <div style="text-align: center;">  <p>2 dot adjacent (vertical)</p> </div> <div style="text-align: center;">  <p>2 dot adjacent (slant)</p> </div> </div>   |      |        |                |            |        |            |                 |            |                 |            |          |        |            |                 |            |                 |            |          |   |     |  |  |                           |  |  |            |

# DEM 480480J VMH-PW-N(C-TOUCH) Product Specification

| 4.0                        | Line defect (LCD /Polarizer backlight black/white line, scratch, stain)  | <table border="1" style="width: 100%; border-collapse: collapse;"> <thead> <tr> <th rowspan="2" style="width: 25%;">Width(mm)</th> <th rowspan="2" style="width: 15%;">Length(m)</th> <th colspan="3" style="width: 55%;">Acceptable Qty</th> </tr> <tr> <th style="width: 15%;">A</th> <th style="width: 15%;">B</th> <th style="width: 25%;">C</th> </tr> </thead> <tbody> <tr> <td style="text-align: center;"><math>\Phi \leq 0.03</math></td> <td style="text-align: center;">Ignore</td> <td colspan="2" style="text-align: center;">Ignore</td> <td rowspan="3" style="text-align: center; vertical-align: middle;">Ignore</td> </tr> <tr> <td style="text-align: center;"><math>0.03 &lt; W \leq 0.04</math></td> <td style="text-align: center;"><math>L \leq 3.0</math></td> <td colspan="2" style="text-align: center;"><math>N \leq 2</math></td> </tr> <tr> <td style="text-align: center;"><math>0.04 &lt; W \leq 0.05</math></td> <td style="text-align: center;"><math>L \leq 2.0</math></td> <td colspan="2" style="text-align: center;"><math>N \leq 1</math></td> </tr> <tr> <td style="text-align: center;"><math>W &gt; 0.05</math></td> <td colspan="3" style="text-align: center;">Define as spot defect</td> <td></td> </tr> </tbody> </table> |                |   |        | Width(mm) | Length(m) | Acceptable Qty |  |  | A | B | C | $\Phi \leq 0.03$ | Ignore | Ignore |  | Ignore | $0.03 < W \leq 0.04$ | $L \leq 3.0$ | $N \leq 2$ |  | $0.04 < W \leq 0.05$ | $L \leq 2.0$ | $N \leq 1$ |  | $W > 0.05$ | Define as spot defect |  |  |  |
|----------------------------|--|--|----------------|---|--------|-----------|-----------|----------------|--|--|---|---|---|------------------|--------|--------|--|--------|----------------------|--------------|------------|--|----------------------|--------------|------------|--|------------|-----------------------|--|--|--|
|                            | Width(mm)  | Length(m)  | Acceptable Qty |   |        |           |           |                |  |  |   |   |   |                  |        |        |  |        |                      |              |            |  |                      |              |            |  |            |                       |  |  |  |
|                            |  |  | A              | B | C      |           |           |                |  |  |   |   |   |                  |        |        |  |        |                      |              |            |  |                      |              |            |  |            |                       |  |  |  |
|                            | $\Phi \leq 0.03$   | Ignore   | Ignore         |   | Ignore |           |           |                |  |  |   |   |   |                  |        |        |  |        |                      |              |            |  |                      |              |            |  |            |                       |  |  |  |
|                            | $0.03 < W \leq 0.04$   | $L \leq 3.0$   | $N \leq 2$     |   |        |           |           |                |  |  |   |   |   |                  |        |        |  |        |                      |              |            |  |                      |              |            |  |            |                       |  |  |  |
| $0.04 < W \leq 0.05$       | $L \leq 2.0$   | $N \leq 1$   |                |   |        |           |           |                |  |  |   |   |   |                  |        |        |  |        |                      |              |            |  |                      |              |            |  |            |                       |  |  |  |
| $W > 0.05$                 | Define as spot defect  |  |                |   |        |           |           |                |  |  |   |   |   |                  |        |        |  |        |                      |              |            |  |                      |              |            |  |            |                       |  |  |  |
| Electronic Components SMT. | Not allow missing parts, solderless connection, cold solder joint, mismatch, The positive and negative polarity opposite |  |                |   |        |           |           |                |  |  |   |   |   |                  |        |        |  |        |                      |              |            |  |                      |              |            |  |            |                       |  |  |  |
| 6.0                        | Display color & Brightness.  | 1. Color: Measuring the color coordinates, The measurement standard according to the datasheet or samples.<br>2. Brightness: Measuring the brightness of White screen, The measurement standard according to the datasheet or Samples.   |                |   |        |           |           |                |  |  |   |   |   |                  |        |        |  |        |                      |              |            |  |                      |              |            |  |            |                       |  |  |  |
| 7.0                        | LCD Mura/Waving/<br>Hot spot   | Not visible through 5% ND filter in 50% gray or judge by limit sample if necessary.  |                |   |        |           |           |                |  |  |   |   |   |                  |        |        |  |        |                      |              |            |  |                      |              |            |  |            |                       |  |  |  |

| 8.0                     | CTP Related                | CTP Cover sensor accidented black/white spot | <table border="1" style="width: 100%; border-collapse: collapse;"> <thead> <tr> <th rowspan="2" style="width: 25%;">Size <math>\Phi</math>(mm)</th> <th colspan="3" style="width: 75%;">Acceptable Qty</th> </tr> <tr> <th style="width: 25%;">A</th> <th style="width: 25%;">B</th> <th style="width: 25%;">C</th> </tr> </thead> <tbody> <tr> <td style="text-align: center;"><math>\Phi \leq 0.1</math></td> <td colspan="2" style="text-align: center;">Ignore</td> <td rowspan="3" style="text-align: center; vertical-align: middle;">Ignore</td> </tr> <tr> <td style="text-align: center;"><math>0.1 &lt; \Phi \leq 0.2</math></td> <td colspan="2" style="text-align: center;"><math>0</math> ( distance <math>&gt; 0.5mm</math> )</td> </tr> <tr> <td style="text-align: center;"><math>0.20 &lt; \Phi \leq 0.25</math></td> <td colspan="2" style="text-align: center;"><math>0</math> ( distance <math>&gt; 0.5mm</math> )</td> </tr> <tr> <td style="text-align: center;"><math>\Phi &gt; 0.25</math></td> <td colspan="3" style="text-align: center;"><math>0</math></td> </tr> </tbody> </table> |   |        | Size $\Phi$ (mm) | Acceptable Qty |  |  | A | B | C | $\Phi \leq 0.1$ | Ignore |  | Ignore | $0.1 < \Phi \leq 0.2$ | $0$ ( distance $> 0.5mm$ ) |  | $0.20 < \Phi \leq 0.25$ | $0$ ( distance $> 0.5mm$ ) |  | $\Phi > 0.25$ | $0$ |  |  |
|-------------------------|----------------------------|--|---|---|--------|------------------|----------------|--|--|---|---|---|-----------------|--------|--|--------|-----------------------|----------------------------|--|-------------------------|----------------------------|--|---------------|-----|--|--|
|                         | Size $\Phi$ (mm)           |  | Acceptable Qty  |   |        |                  |                |  |  |   |   |   |                 |        |  |        |                       |                            |  |                         |                            |  |               |     |  |  |
|                         |                            |  | A   | B | C      |                  |                |  |  |   |   |   |                 |        |  |        |                       |                            |  |                         |                            |  |               |     |  |  |
|                         | $\Phi \leq 0.1$            |  | Ignore  |   | Ignore |                  |                |  |  |   |   |   |                 |        |  |        |                       |                            |  |                         |                            |  |               |     |  |  |
|                         | $0.1 < \Phi \leq 0.2$      |  | $0$ ( distance $> 0.5mm$ )  |   |        |                  |                |  |  |   |   |   |                 |        |  |        |                       |                            |  |                         |                            |  |               |     |  |  |
| $0.20 < \Phi \leq 0.25$ | $0$ ( distance $> 0.5mm$ ) |  |   |   |        |                  |                |  |  |   |   |   |                 |        |  |        |                       |                            |  |                         |                            |  |               |     |  |  |
| $\Phi > 0.25$           | $0$                        |  |   |   |        |                  |                |  |  |   |   |   |                 |        |  |        |                       |                            |  |                         |                            |  |               |     |  |  |

# DEM 480480J VMH-PW-N(C-TOUCH) Product Specification

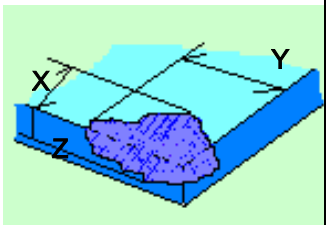
|                 |                 | CTP Cover scratch                      | Width(mm)   |  |                         | Ignore(mm) | Acceptable Qty |   |                 |                 |                                   |   |  |  |   |  |  |
|-----------------|-----------------|--|---|--|-------------------------|------------|----------------|---|-----------------|-----------------|-----------------------------------|---|--|--|---|--|--|
|                 |                 |  |   |  | A                       |            | B              | C |                 |                 |                                   |   |  |  |   |  |  |
|                 |                 |  | $\Phi \leq 0.03$  |  | Ignore                  |            | Ignore         |   |                 |                 |                                   |   |  |  |   |  |  |
|                 |                 |  | $0.03 < W \leq 0.04$  |  | $L \leq 3.0$            |            | $N \leq 2$     |   |                 |                 |                                   |   |  |  |   |  |  |
|                 |                 |  | $0.04 < W \leq 0.05$  |  | $L \leq 2.0$            |            | $N \leq 1$     |   |                 |                 |                                   |   |  |  |   |  |  |
| $0.05 < W$      |                 | Define as spot defect                  |   |  |                         |            |                |   |                 |                 |                                   |   |  |  |   |  |  |
|                 |                 | CTP Cover Pinhole/<br>Lack of ink      | Zone  |  | Acceptable Qty          |            |                |   |                 |                 |                                   |   |  |  |   |  |  |
|                 |                 |  | Size (mm)   |  | C                       |            |                |   |                 |                 |                                   |   |  |  |   |  |  |
|                 |                 |  | $\Phi \leq 0.1$   |  | Ignore                  |            |                |   |                 |                 |                                   |   |  |  |   |  |  |
|                 |                 |  | $0.1 < \Phi \leq 0.25$  |  | 3(distance $\geq 6$ mm) |            |                |   |                 |                 |                                   |   |  |  |   |  |  |
|                 |                 |  | $0.25 < \Phi \leq 0.3$  |  | 2(distance $\geq 6$ mm) |            |                |   |                 |                 |                                   |   |  |  |   |  |  |
| $\Phi > 0.3$    |                 | 0                                      |   |  |                         |            |                |   |                 |                 |                                   |   |  |  |   |  |  |
|                 |                 | CTP Bonding bubble/<br>accidented spot | Size $\Phi$ (mm)  |  | Acceptable Qty          |            |                |   |                 |                 |                                   |   |  |  |   |  |  |
|                 |                 |  |   |  | A                       | B          |                |   |                 |                 |                                   |   |  |  |   |  |  |
|                 |                 |  | $\Phi \leq 0.1$   |  | Ignore                  |            |                |   |                 |                 |                                   |   |  |  |   |  |  |
|                 |                 |  | $0.1 < \Phi \leq 0.2$   |  | 2(distance $\geq 6$ mm) |            |                |   |                 |                 |                                   |   |  |  |   |  |  |
|                 |                 |  | $0.2 < \Phi \leq 0.25$  |  | 2(distance $\geq 6$ mm) |            |                |   |                 |                 |                                   |   |  |  |   |  |  |
| $\Phi > 0.25$   |                 | 0                                      |   |  |                         |            |                |   |                 |                 |                                   |   |  |  |   |  |  |
|                 |                 | Assembly deflection                    | beyond the edge of backlight $\leq 0.2$ mm  |  |                         |            |                |   |                 |                 |                                   |   |  |  |   |  |  |
|                 |                 | CTP cover broken                       | <table border="1" style="margin: auto; border-collapse: collapse;"> <thead> <tr> <th style="width: 33%;">X</th> <th style="width: 33%;">Y</th> <th style="width: 33%;">Z</th> </tr> </thead> <tbody> <tr> <td style="text-align: center;"><math>X \leq 0.5</math>mm</td> <td style="text-align: center;"><math>Y \leq 0.5</math>mm</td> <td style="text-align: center;"><math>Z &lt; \text{cover thickness}</math><br/>s</td> </tr> </tbody> </table> |  |                         | X          | Y              | Z | $X \leq 0.5$ mm | $Y \leq 0.5$ mm | $Z < \text{cover thickness}$<br>s |  |  |  | <p>Circuitry broken is not allowed.</p> |  |  |
| X               | Y               | Z                                      |   |  |                         |            |                |   |                 |                 |                                   |   |  |  |   |  |  |
| $X \leq 0.5$ mm | $Y \leq 0.5$ mm | $Z < \text{cover thickness}$<br>s      |   |  |                         |            |                |   |                 |                 |                                   |   |  |  |   |  |  |
| X : length      |                 |  |   |  |                         |            |                |   |                 |                 |                                   |   |  |  |   |  |  |
| Y : width       |                 |  |   |  |                         |            |                |   |                 |                 |                                   |   |  |  |   |  |  |
|                 |                 | Z : height                             |   |  |                         |            |                |   |                 |                 |                                   |   |  |  |   |  |  |

# DEM 480480J VMH-PW-N(C-TOUCH) Product Specification

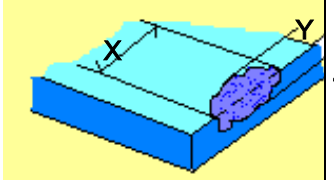
|  |  |                  |                                    |                       |                     |   |
|--|--|------------------|------------------------------------|-----------------------|---------------------|---|
|  |  | CTP cover broken | X                                  | Y                     | Z                   |  |
|  |  | X : length       | $X \leq 0.3\text{mm}$              | $Y \leq 0.3\text{mm}$ | Z < cover thickness |   |
|  |  | Y : width        | * Circuitry broken is not allowed. |                       |                     |   |
|  |  | Z : height       |                                    |                       |                     |   |

## Criteria ( functional items)

| Number | Items                 | Criteria (mm) |
|--------|-----------------------|---------------|
| 1      | No display            | Not allowed   |
| 2      | Missing segment       | Not allowed   |
| 3      | Short                 | Not allowed   |
| 4      | Backlight no lighting | Not allowed   |
| 5      | CTP no function       | Not allowed   |

**10. Reliability Test Result**

| Item  | Condition   | Inspection after test   |
|---|---|---|
| High Temperature Operating                    | +70°C,96h   | Inspection after 2~4hours<br>storage at room<br>temperature, the sample<br>shall be free from defects:<br>1. Air bubble in the LCD;<br>2. Non-display;<br>3. Missing segments/line;<br>4. Glass crack;<br>5. Current IDD is twice<br>higher than initial value. |
| Low Temperature Operating                     | -20°C, 96h  |   |
| High Temperature Storage                      | +80°C, 96h  |   |
| Low Temperature Storage                       | -30°C, 96h  |   |
| High Temperature<br>& High Humidity Operating | +60°C, 90% RH ,96h  |   |
| Thermal Shock (Non-operation)                 | -10°C,30 min ↔ +60°C,30 min,<br>Change time: 5min 20CYC.  |   |
| ESD Test                                      | C=150pF, R=330, 5points/panel<br>Air:±8kV, 5times; Contact:±6kV, 5 times;<br>(Environment: 15°C~35°C, 30%~60%).                     |   |
| Vibration (Non-operation)                     | Frequency range: 10~55Hz, Stroke:1.5mm<br>Sweep:10Hz~55Hz~10Hz 2 hours for each<br>direction of X.Y.Z. (6 hours for total) (Package |   |
| Box Drop Test                                 | 1 Corner 3 Edges 6 faces,80cm(MEDIUM BOX)   |   |

Remark:

1. The test samples should be applied to only one test item.
2. Sample size for each test item is 5~10pcs.
3. For Damp Proof Test, Pure water (Resistance > 10MΩ) should be used.
4. In case of malfunction defect caused by ESD damage, if it would be recovered to normal state after resetting, it would be judged as a good part.
5. Failure Judgment Criterion: Basic Specification, Electrical Characteristic, Mechanical Characteristic, Optical Characteristic.
6. The color fading mura of polarizing filter should not care.



## **11. Cautions and Handling Precautions**

### **11.1 Handling and Operating the Module**

- (1) When the module is assembled, it should be attached to the system firmly.  
Do not warp or twist the module during assembly work.
- (2) Protect the module from physical shock or any force. In addition to damage, this may cause improper operation or damage to the module and back-light unit.
- (3) Note that polarizer is very fragile and could be easily damaged. Do not press or scratch the surface.
- (4) Do not allow drops of water or chemicals to remain on the display surface.  
If you have the droplets for a long time, staining and discoloration may occur.
- (5) If the surface of the polarizer is dirty, clean it using some absorbent cotton or soft cloth.
- (6) The desirable cleaners are water, IPA (Isopropyl Alcohol) or Hexane.  
Do not use ketene type materials (ex. Acetone), Ethyl alcohol, Toluene, Ethyl acid or Methyl chloride. It might permanent damage to the polarizer due to chemical reaction.
- (7) If the liquid crystal material leaks from the panel, it should be kept away from the eyes or mouth. In case of contact with hands, legs, or clothes, it must be washed away thoroughly with soap.
- (8) Protect the module from static; it may cause damage to the CMOS ICs.
- (9) Use finger-stalls with soft gloves in order to keep display clean during the incoming inspection and assembly process.
- (10) Do not disassemble the module.
- (11) Protection film for polarizer on the module shall be slowly peeled off just before use so that the electrostatic charge can be minimized.
- (12) Pins of I/F connector shall not be touched directly with bare hands.
- (13) Do not connect, disconnect the module in the "Power ON" condition.
- (14) Power supply should always be turned on/off by the item 6.1 Power On Sequence & 6.2 Power Off Sequence

### **11.2 Storage and Transportation.**

- (1) Do not leave the panel in high temperature, and high humidity for a long time.  
It is highly recommended to store the module with temperature from 0°C to 35°C and relative humidity of less than 70%
- (2) Do not store the TFT-LCD module in direct sunlight.
- (3) The module shall be stored in a dark place. When storing the modules for a long time, be sure to adopt effective measures for protecting the modules from strong ultraviolet radiation, sunlight, or fluorescent light.
- (4) It is recommended that the modules should be stored under a condition where no condensation is allowed. Formation of dewdrops may cause an abnormal operation or a failure of the module.  
In particular, the greatest possible care should be taken to prevent any module from being operated where condensation has occurred inside.
- (5) This panel has its circuitry FPC on the bottom side and should be handled carefully in order not to be stressed.