

Display Elektronik GmbH

# DATA SHEET

*TFT MODULE*

**DEM 240320P1 VMX-PW-N**

**3,4" TFT**

Product Specification

Ver.: 1

04.12.2024

**Revision History**

<b>Revision</b>	<b>Date</b>	<b>Originator</b>	<b>Detail</b>	<b>Remarks</b>
0	17.10.2024	LQ	Initial Release	-
1	04.12.2024	LL	Modify Weight Modify Current Consumption All White Modify Optical Characteristics Modify Outline Drawing(B)	P4 P5 P6 P23

**Table of Contents**

No.	Item	Page
1.	General Description .....	4
2.	Module Parameter .....	4
3.	Absolute Maximum Ratings .....	4
4.	DC Characteristics .....	5
5.	Backlight Characteristics .....	5
5.1.	Backlighting circuit .....	5
6.	Optical Characteristics .....	6
6.1.	Optical Characteristics .....	6
6.2.	Definition of Response Time .....	6
6.3.	Definition of Contrast Ratio .....	7
6.4.	Definition of Viewing Angles.....	7
6.5.	Definition of Color Appearance .....	7
6.6.	Definition of Surface Luminance, Uniformity and Transmittance.....	8
7.	Block Diagram and Power Supply .....	9
8.	Interface Pins Definition .....	10
9.	AC Characteristics .....	11
9.1.	Serial Interface Characteristics (4-line serial): .....	11
9.2.	Reset Timing .....	12
10.	Quality Assurance .....	13
10.1.	Purpose.....	13
10.2.	Standard for Quality Test.....	13
10.3.	Nonconforming Analysis & Disposition .....	13
10.4.	Agreement Items.....	13
10.5.	Standard of the Product Visual Inspection .....	14
10.6.	Inspection Specification .....	14
10.7.	Classification of Defects.....	18
10.8.	Identification/marketing criteria .....	18
10.9.	Packing .....	18
11.	Reliability Specification .....	19
12.	Precautions and Warranty .....	20
12.1.	Safety .....	20
12.2.	Handling.....	20
12.3.	Storage.....	20
12.4.	Metal Pin (Apply to Products with Metal Pins) .....	20
12.5.	Operation .....	21
12.6.	Static Electricity .....	21
12.7.	Limited Warranty .....	21
13.	Outline Drawing .....	22

## 1. General Description

The specification is a transmissive type color active matrix liquid crystal display (LCD) which uses amorphous thin film transistor (TFT) as switching devices. This product is composed of a TFT-LCD panel, driver ICs and a backlight unit.

## 2. Module Parameter

Features	Details	Unit
Display Size(Diagonal)	3.4"	-
LCD Type	IPS TFT	-
Display Mode	Transmissive /Normally Black	-
Resolution	240 RGB x 320	Pixels
View Direction	FULL VIEW	Best Image
Module Outline	53.91(H) x 74.33(V) x 1.99(T) (Note1)	mm
Active Area	(51.27) (H) x (68.36) (V)	mm
Pixel Size	0.213 x 0.213	mm
Pixel Arrangement	RGB Vertical Stripe	-
Display Colors	16.7 Million	-
Interface	4-Wire SPI	-
With or without Touch Panel	Without	-
Driver IC	ST7789P3 (Sitronix)	-
Operating Temperature	-30°C to +80°C	°C
Storage Temperature	-30°C to +85°C	°C
Weight	17	g

Note 1: Exclusive hooks, posts, FFC/FPC tail etc.

## 3. Absolute Maximum Ratings

GND=0V, Ta=25°C

Item	Symbol	Min.	Max.	Unit
Supply Voltage	VDD	-0.3	4.6	V
Storage Temperature	T <sub>STG</sub>	-30	+80	°C
Operating Temperature	T <sub>OP</sub>	-30	+85	°C

Note 1: If Ta below 50°C, the maximal humidity is 90%RH, if Ta over 50°C, absolute humidity should be less than 60%RH.

Note 2: The response time will be extremely slow when the operating temperature is around -10°C, and the back ground will become darker at high temperature operating.

4. DC Characteristics

Item	Symbol	Min.	Typ.	Max.	Unit
Supply Voltage	VDD	2.4	2.8	3.3	V
Logic Low Input Voltage	V <sub>IL</sub>	GND	-	0.3*VDD	V
Logic High Input Voltage	V <sub>IH</sub>	0.7*VDD	-	VDD	V
Logic Low Output Voltage	V <sub>OL</sub>	GND	-	0.2*VDD	V
Logic High Output Voltage	V <sub>OH</sub>	0.8*VDD	-	VDD	V
Current Consumption All White	I <sub>DD</sub>	-	11	-	mA

5. Backlight Characteristics

Item	Symbol	Condition	Min.	Typ.	Max.	Unit
Forward Voltage	V <sub>F</sub>	T <sub>a</sub> =25 °C, I <sub>F</sub> =20mA/LED	5.6	6.0	6.6	V
Forward Current	I <sub>F</sub>	T <sub>a</sub> =25 °C, V <sub>F</sub> =3.0V/LED	-	80	-	mA
Power Dissipation	P <sub>D</sub>	-	-	480	-	mW
Uniformity	Avg	-	-	80	-	%
LED Lifetime (25°C)	-	-	-	30.000	-	Hrs
Drive Method	Constant Current					
LED Configuration	8 White LEDs (2 LEDs in string and 4 groups in parallel)					

Note1: LED Lifetime defined as follows: The final brightness is at 50% of original brightness.  
 The environmental conducted under ambient air flow,  
 at T<sub>a</sub>=25°C ± 2°C, 60%RH ± 5%, I<sub>F</sub>=20mA/LED.

5.1. Backlighting Circuit

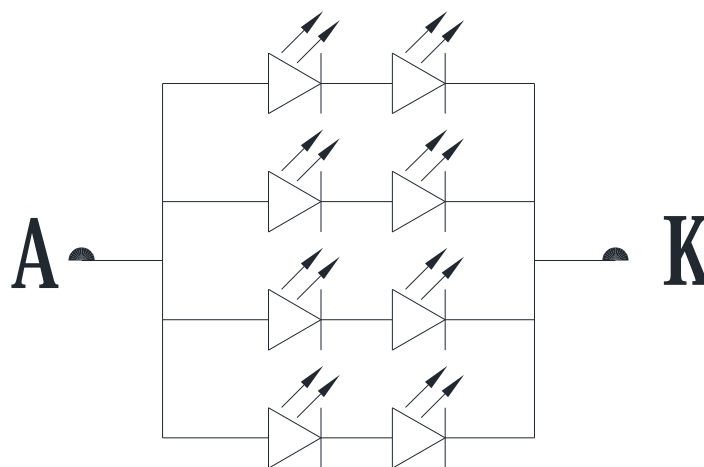

6. Optical Characteristics

6.1. Optical Characteristics

Ta=25°C, VDD=2.8V

	Item	Symbol	Condition	Specification			Unit	
				Min.	Typ.	Max.		
Backlight On (Transmissive Mode)	Luminance on TFT(I <sub>f</sub> =20mA/LED)	Lv	Normally viewing angle θx = φY = 0°	400	500	-	cd/m <sup>2</sup>	
	Contrast Ratio(See 7.3)	CR		1000	1200	-		
	Response Time (See 6.2)	TR+TF		-	30	35	ms	
	Chromaticity Transmissive (See 6.5)	Red	XR	Center CR≥10	0.603	0.653	0.703	
			YR		0.291	0.341	0.391	
		Green	XG		0.263	0.313	0.363	
			YG		0.600	0.650	0.700	
		Blue	XB		0.069	0.119	0.169	
			YB		0.050	0.100	0.150	
		White	XW		0.240	0.280	0.340	
			YW		0.278	0.328	0.378	
	Viewing Angle (See 6.4)	Horizontal	θx+	75	80	-	Deg.	
			θx-	75	80	-		
		Vertical	φY+	75	80	-		
φY-			75	80	-			
NTSC Ratio(Gamut)				60	65	-	%	

6.2. Definition of Response Time

6.2.1. Normally Black Type (Negative)

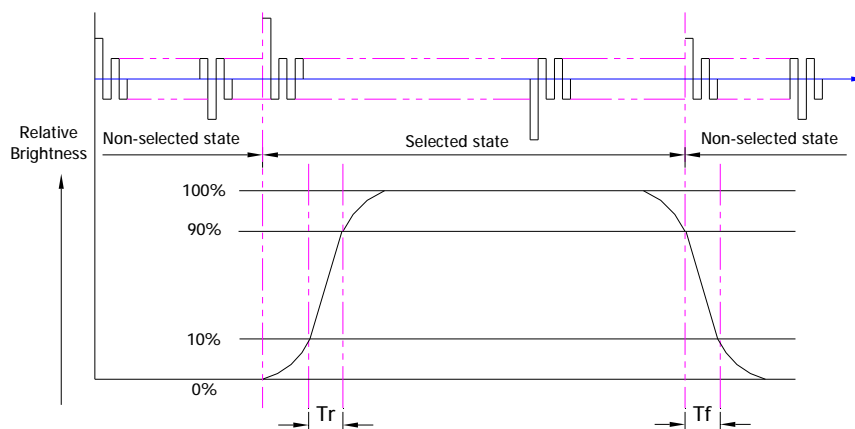

Tr is the time it takes to change from non-selected stage with relative luminance 10% to selected state with relative luminance 90%;

Tf is the time it takes to change from selected state with relative luminance 90% to non-selected state with relative luminance 10%.

Note: Measuring machine: LCD-5100

6.2.2. Normally White Type (Positive)

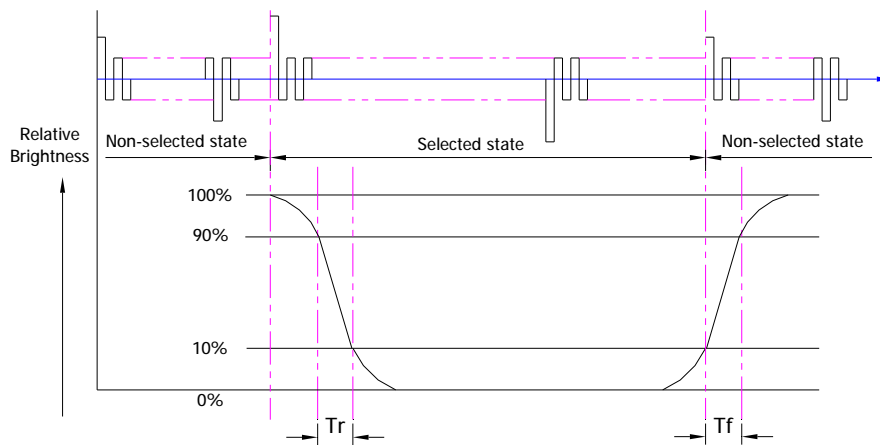

Tr is the time it takes to change from non-selected stage with relative luminance 90% to selected state with relative luminance 10%;

Tf is the time it takes to change from selected state with relative luminance 10% to non-selected state with relative luminance 90%;

Note: Measuring machine: LCD-5100 or EQUI

6.3. Definition of Contrast Ratio

Contrast is measured perpendicular to display surface in reflective and transmissive mode. The measurement condition is:

Measuring Equipment	Eldim or Equivalent
Measuring Point Diameter	3mm//1mm
Measuring Point Location	Active Area centre point
Test pattern	A: All Pixels white B: All Pixel black
Contrast setting	Maximum

Definitions: CR (Contrast) = Luminance of White Pixel / Luminance of Black Pixel

6.4. Definition of Viewing Angles

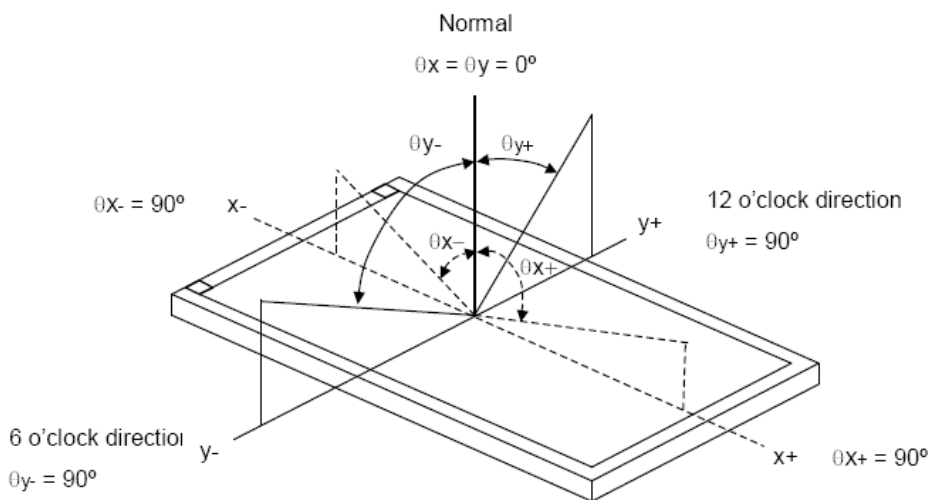

Measuring machine: LCD-5100 or EQUI

6.5. Definition of Color Appearance

R, G, B and W are defined by (x, y) on the IE chromaticity diagram  
 NTSC=area of RGB triangle/area of NTSC triangleX100%

Measuring picture: Red, Green, Blue and White (Measuring machine: BM-7)

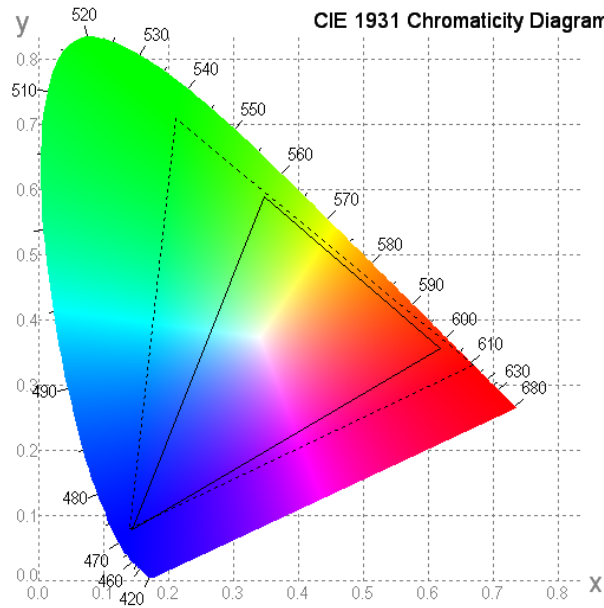

**6.6. Definition of Surface Luminance, Uniformity and Transmittance**

Using the transmissive mode measurement approach, measure the white screen luminance of the display panel and backlight.

- 6.6.1. Surface Luminance:  $L_V = \text{average} (L_{P1}:L_{P9})$
- 6.6.2. Uniformity =  $\text{Minimal} (L_{P1}:L_{P9}) / \text{Maximal} (L_{P1}:L_{P9}) * 100\%$
- 6.6.3. Transmittance =  $L_V \text{ on LCD} / L_V \text{ on Backlight} * 100\%$

Note: Measuring machine: BM-7

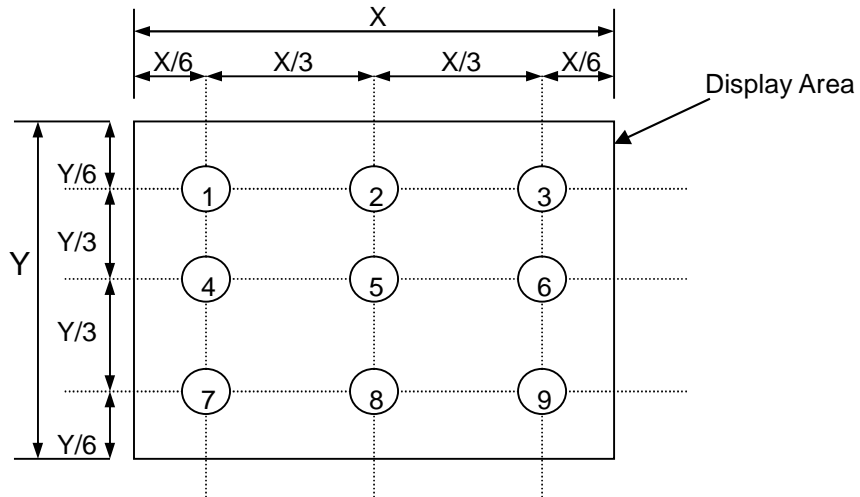



### 7. Block Diagram and Power Supply

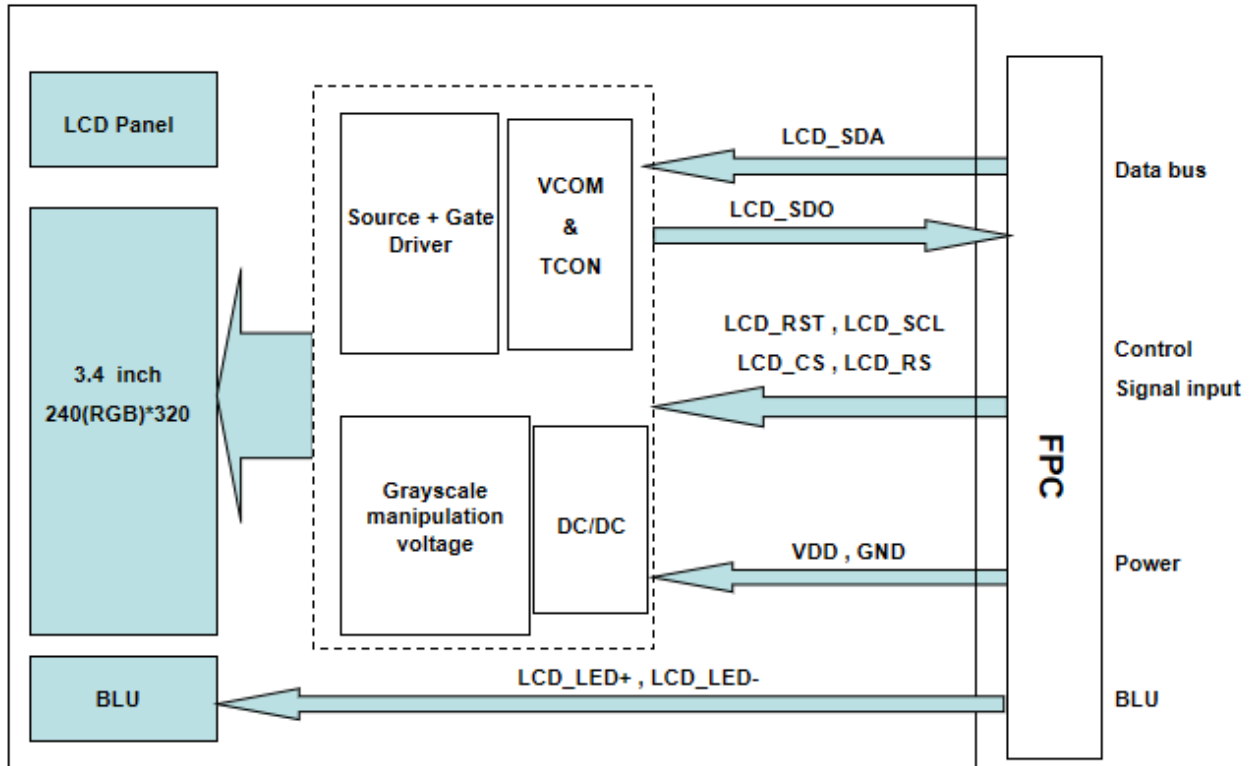

**8. Interface Pins Definition**

<b>No.</b>	<b>Symbol</b>	<b>Function</b>
1	GND	Ground
2	LCD_RST	This signal will reset the device and it must be applied to properly initialize the chip. Signal is active low.
3	LCD_SCL	Serial interface clock signal.
4	GND	Ground
5	LCD_CS	Chip selection signal.
6	LCD_SDA	Serial input data signal.
7	LCD_SDO	Serial output data signal.
8	GND	Ground
9	VDD	Power supply.
10	LCD_RS	Display data/command selection.
11	LCD_LED+	Backlight driver Anode.
12	LCD_LED-	Backlight driver Cathode.
13	NC	No connected
14	NC	No connected
15	NC	No connected
16	NC	No connected
17	NC	No connected
18	NC	No connected

9. AC Characteristics

9.1. Serial Interface Characteristics (4-line serial):

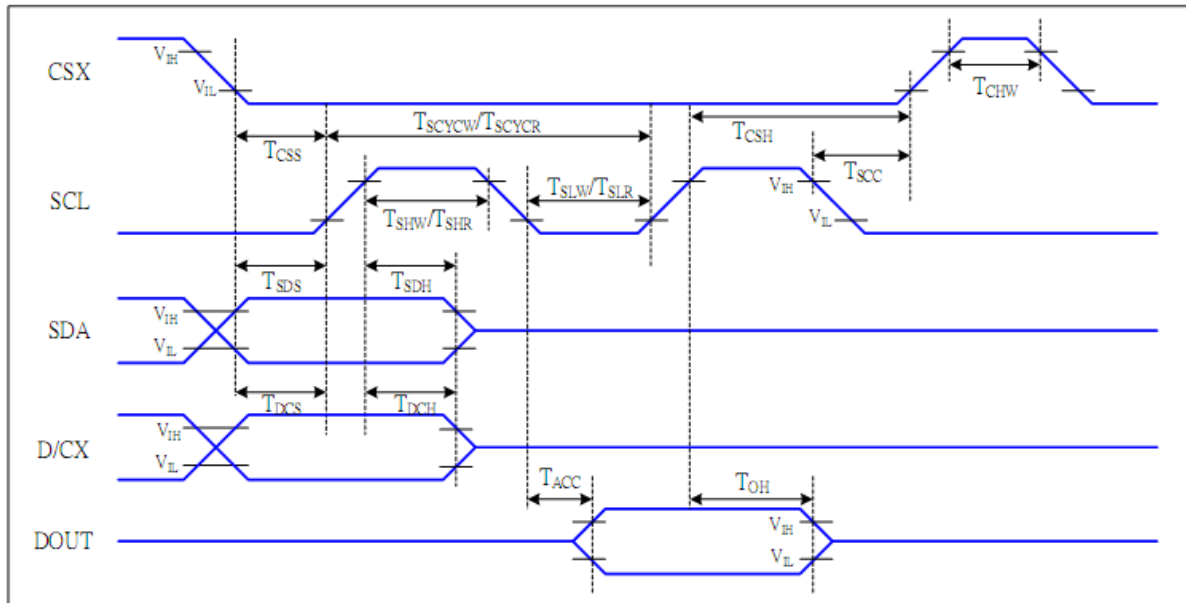

4-line serial Interface Timing Characteristics

VDDI=1.65 to 3.3V, VDD=2.4 to 3.3V, AGND=DGND=0V, Ta=25°C

Signal	Symbol	Parameter	MIN	MAX	Unit	Description
CSX	T <sub>css</sub>	Chip select setup time (write)	TBD	-	ns	
	T <sub>sch</sub>	Chip select hold time (write)	TBD	-	ns	
	T <sub>css</sub>	Chip select setup time (read)	TBD	-	ns	
	T <sub>sccl</sub>	Chip select hold time (read)	TBD	-	ns	
	T <sub>chw</sub>	Chip select "H" pulse width	TBD	-	ns	
SCL	T <sub>scycw</sub>	Serial clock cycle (Write)	TBD	-	ns	-write command & data ram
	T <sub>shw</sub>	SCL "H" pulse width (Write)	TBD	-	ns	
	T <sub>slw</sub>	SCL "L" pulse width (Write)	TBD	-	ns	
	T <sub>scycr</sub>	Serial clock cycle (Read)	TBD	-	ns	-read command & data ram
	T <sub>shr</sub>	SCL "H" pulse width (Read)	TBD	-	ns	
	T <sub>slr</sub>	SCL "L" pulse width (Read)	TBD	-	ns	
D/CX	T <sub>dcs</sub>	D/CX setup time	TBD	-	ns	
	T <sub>dch</sub>	D/CX hold time	TBD	-	ns	
SDA (DIN)	T <sub>sdh</sub>	Data setup time	TBD	-	ns	
	T <sub>sdh</sub>	Data hold time	TBD	-	ns	
DOUT	T <sub>acc</sub>	Access time	TBD	TBD	ns	For maximum CL=30pF
	T <sub>oh</sub>	Output disable time	TBD	TBD	ns	For minimum CL=8pF

4-line serial Interface Characteristics

9.2. Reset Timing

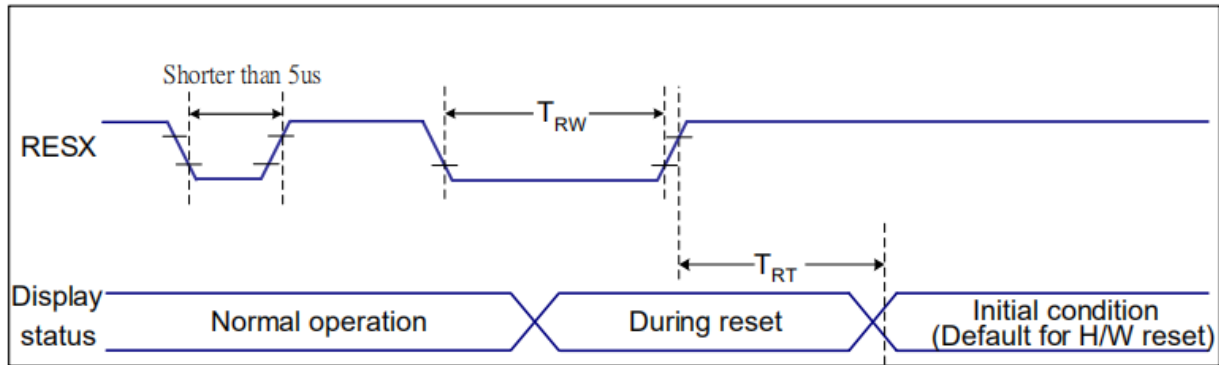

VDDI=1.65 to 3.3V, VDD=2.4 to 3.3V, AGND=DGND=0V, Ta=25°C

Related Pins	Symbol	Parameter	MIN	MAX	Unit
RESX	TRW	Reset pulse duration	TBD	-	us
	TRT	Reset cancel	-	TBD (Note 1, 5)	ms
-			TBD (Note 1, 6, 7)	ms	

Notes:

1. The reset cancel includes also required time for loading ID bytes, VCOM setting and other settings from NVM (or similar device) to registers. This loading is done every time when there is HW reset cancel time (tRT) within 5 ms after a rising edge of RESX.
2. Spike due to an electrostatic discharge on RESX line does not cause irregular system reset according to the table below:

RESX Pulse	Action
Shorter than 5us	Reset Rejected
Longer than 9us	Reset
Between 5us and 9us	Reset starts

3. During the Resetting period, the display will be blanked (The display is entering blanking sequence, which maximum time is 120 ms, when Reset Starts in Sleep Out –mode. The display remains the blank state in Sleep In –mode.) and then return to Default condition for Hardware Reset.

4. Spike Rejection also applies during a valid reset pulse as shown below:

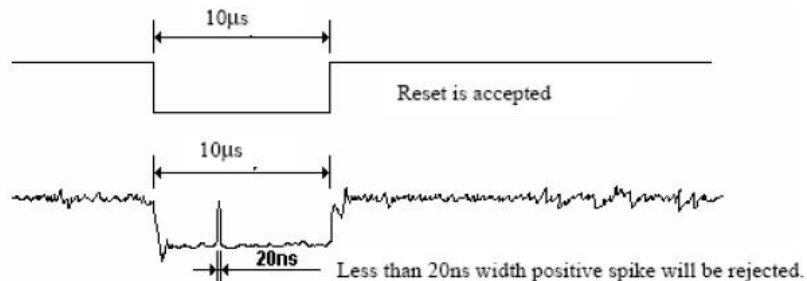

5. When Reset applied during Sleep In Mode.
6. When Reset applied during Sleep Out Mode.
7. It is necessary to wait 5msec after releasing RESX before sending commands. Also Sleep Out command cannot be sent for 120msec.

## **10. Quality Assurance**

### **10.1. Purpose**

This standard for Quality Assurance assures the quality of LCD module products supplied to customer.

### **10.2. Standard for Quality Test**

#### 10.2.1. Sampling Plan:

GB2828.1-2012

Single sampling, general inspection level II

#### 10.2.2. Sampling Criteria:

Visual inspection: AQL 1.5

Electrical functional: AQL 0.65.

#### 10.2.3. Reliability Test:

Detailed requirement refer to Reliability Test Specification.

### **10.3. Nonconforming Analysis & Disposition**

#### 10.3.1. Nonconforming analysis:

10.3.2. Customer should provide overall information of non-conforming sample for their complaints.

10.3.3. After receipt of detailed information from customer, the analysis of nonconforming parts usually should be finished in one week.

10.3.4. If cannot finish the analysis on time, customer will be notified with the progress status.

10.3.5. Disposition of nonconforming:

10.3.6. Non-conforming product over PPM level will be replaced.

10.3.7. The cause of non-conformance will be analyzed. Corrective action will be discussed and implemented.

### **10.4. Agreement Items**

Shall negotiate with customer if the following situation occurs:

10.4.1. There is any discrepancy in standard of quality assurance.

10.4.2. Additional requirement to be added in product specification.

10.4.3. Any other special problem.

**10.5. Standard of the Product Visual Inspection**

- 10.5.1. Appearance inspection:
- 10.5.2. The inspection must be under illumination about 1000 – 1500 lx, and the distance of view must be at 30cm ± 2cm.
- 10.5.3. The viewing angle should be 45° from the vertical line without reflection light or follows customer's viewing angle specifications.
- 10.5.4. Definition of area: A Zone: Active Area, B Zone: Viewing Area,

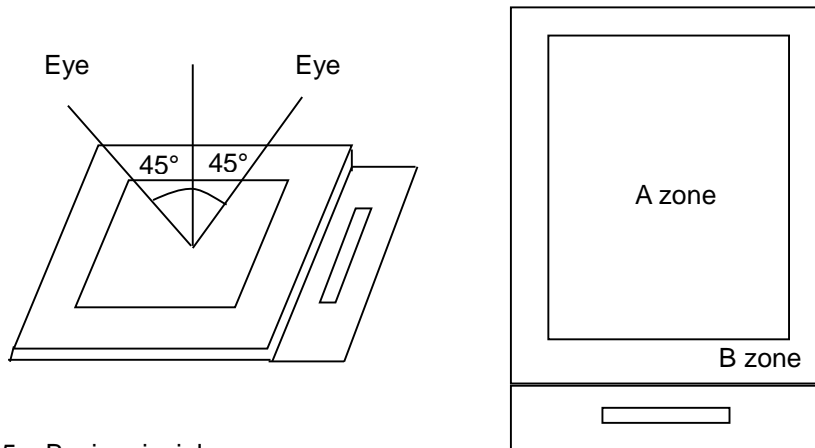

- 10.5.5. Basic principle:
- 10.5.6. A set of sample to indicate the limit of acceptable quality level must be discussed by both us and customer when there is any dispute happened.
- 10.5.7. New item must be added on time when it is necessary.

**10.6. Inspection Specification**

No.	Item	Criteria (Unit: mm)																			
01	Black / White spot Foreign material (Round type) Pinholes Stain Particles inside cell. (Minor defect)	$\varphi = (a + b) / 2$	<table border="1"> <thead> <tr> <th>Size</th> <th>Area</th> <th>Acc. Qty</th> </tr> </thead> <tbody> <tr> <td><math>\varphi \leq 0.10</math></td> <td></td> <td>Ignore</td> </tr> <tr> <td><math>0.10 &lt; \varphi \leq 0.15</math></td> <td></td> <td>2</td> </tr> <tr> <td><math>0.15 &lt; \varphi \leq 0.25</math></td> <td></td> <td>1</td> </tr> <tr> <td><math>0.25 &lt; \varphi</math></td> <td></td> <td>0</td> </tr> <tr> <td>Total</td> <td></td> <td>2 no include <math>\varphi \leq 0.10</math></td> </tr> </tbody> </table>	Size	Area	Acc. Qty	$\varphi \leq 0.10$		Ignore	$0.10 < \varphi \leq 0.15$		2	$0.15 < \varphi \leq 0.25$		1	$0.25 < \varphi$		0	Total		2 no include $\varphi \leq 0.10$
			Size	Area	Acc. Qty																
$\varphi \leq 0.10$		Ignore																			
$0.10 < \varphi \leq 0.15$		2																			
$0.15 < \varphi \leq 0.25$		1																			
$0.25 < \varphi$		0																			
Total		2 no include $\varphi \leq 0.10$																			
Distance between 2 defects should more than 3mm apart.																					

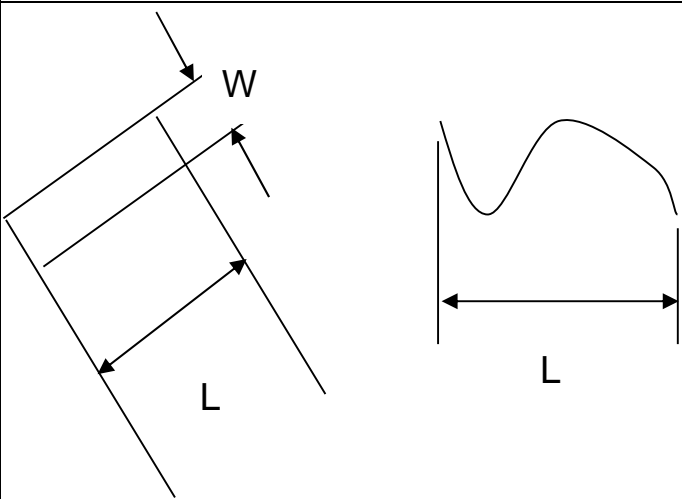
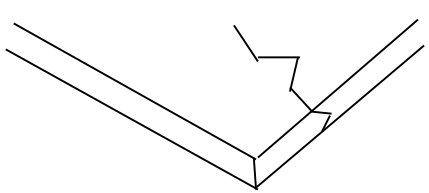
<p>02</p>	<p>Electrical Defect (Minor defect)</p>	<table border="1"> <thead> <tr> <th></th> <th>Display Area</th> <th>Total</th> <th></th> </tr> </thead> <tbody> <tr> <td>Bright dot</td> <td>0</td> <td>0</td> <td rowspan="3">Note1</td> </tr> <tr> <td>Dark dot</td> <td><math>N \leq 2</math></td> <td><math>N \leq 2</math></td> </tr> <tr> <td>Total dot</td> <td><math>N \leq 2</math></td> <td><math>N \leq 2</math></td> </tr> <tr> <td>Mura</td> <td colspan="2">Not visible through 5% ND filters.</td> <td>Note 2</td> </tr> </tbody> </table> <p>Remark: 1. Bright dot caused by scratch and foreign object accords to item 1.</p>		Display Area	Total		Bright dot	0	0	Note1	Dark dot	$N \leq 2$	$N \leq 2$	Total dot	$N \leq 2$	$N \leq 2$	Mura	Not visible through 5% ND filters.		Note 2
	Display Area	Total																		
Bright dot	0	0	Note1																	
Dark dot	$N \leq 2$	$N \leq 2$																		
Total dot	$N \leq 2$	$N \leq 2$																		
Mura	Not visible through 5% ND filters.		Note 2																	
<p>03</p>	<p>Black and White line Scratch Foreign material (Line type) (Minor defect)</p>	 <table border="1"> <thead> <tr> <th>Length</th> <th>Width</th> <th>Acc. Qty</th> </tr> </thead> <tbody> <tr> <td>/</td> <td><math>W \leq 0.03</math></td> <td>Ignore</td> </tr> <tr> <td><math>L \leq .5</math></td> <td><math>0.03 &lt; W \leq 0.5</math></td> <td>3</td> </tr> <tr> <td><math>L \leq 2.5</math></td> <td><math>0.05 &lt; W \leq 0.10</math></td> <td>2</td> </tr> <tr> <td>/</td> <td><math>0.1 &lt; W</math></td> <td>0</td> </tr> <tr> <td colspan="2">Total</td> <td>3</td> </tr> </tbody> </table> <p>Distance between 2 defects should more than 3mm apart. Scratches not viewable through the back of the display are acceptable.</p>	Length	Width	Acc. Qty	/	$W \leq 0.03$	Ignore	$L \leq .5$	$0.03 < W \leq 0.5$	3	$L \leq 2.5$	$0.05 < W \leq 0.10$	2	/	$0.1 < W$	0	Total		3
Length	Width	Acc. Qty																		
/	$W \leq 0.03$	Ignore																		
$L \leq .5$	$0.03 < W \leq 0.5$	3																		
$L \leq 2.5$	$0.05 < W \leq 0.10$	2																		
/	$0.1 < W$	0																		
Total		3																		
<p>04</p>	<p>Glass Crack (Minor defect)</p>	 <p>Crack is potential to enlarge, any type is not allowed.</p>																		

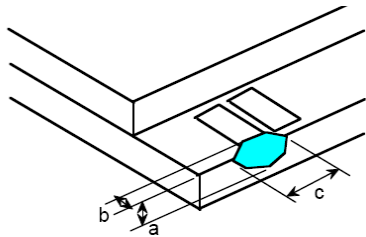
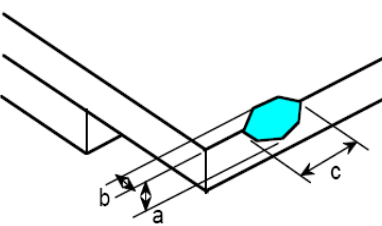
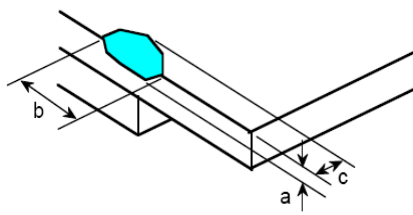
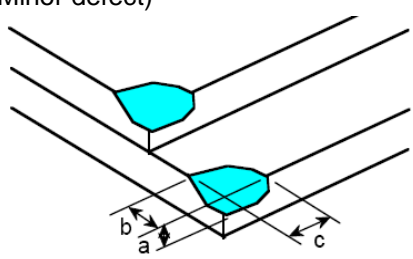
<p>05</p>	<p>Glass Chipping Pad Area: (Minor defect)</p> 	<table border="1"> <thead> <tr> <th>Length and Width</th> <th>Acc. Qty</th> </tr> </thead> <tbody> <tr> <td><math>c &gt; 3.0, b &lt; 1.0</math></td> <td>1</td> </tr> <tr> <td><math>c &lt; 3.0, b &lt; 1.0</math></td> <td>3</td> </tr> <tr> <td colspan="2"><math>a &lt; \text{Glass Thickness}</math></td> </tr> </tbody> </table>	Length and Width	Acc. Qty	$c > 3.0, b < 1.0$	1	$c < 3.0, b < 1.0$	3	$a < \text{Glass Thickness}$			
Length and Width	Acc. Qty											
$c > 3.0, b < 1.0$	1											
$c < 3.0, b < 1.0$	3											
$a < \text{Glass Thickness}$												
<p>06</p>	<p>Glass Chipping Rear of Pad Area: (Minor defect)</p> 	<table border="1"> <thead> <tr> <th>Length and Width</th> <th>Acc. Qty</th> </tr> </thead> <tbody> <tr> <td><math>c &gt; 3.0, b &lt; 1.0</math></td> <td>1</td> </tr> <tr> <td><math>c &lt; 3.0, b &lt; 1.0</math></td> <td>2</td> </tr> <tr> <td><math>c &lt; 3.0, b &lt; 0.5</math></td> <td>4</td> </tr> <tr> <td colspan="2"><math>a &lt; \text{Glass Thickness}</math></td> </tr> </tbody> </table>	Length and Width	Acc. Qty	$c > 3.0, b < 1.0$	1	$c < 3.0, b < 1.0$	2	$c < 3.0, b < 0.5$	4	$a < \text{Glass Thickness}$	
Length and Width	Acc. Qty											
$c > 3.0, b < 1.0$	1											
$c < 3.0, b < 1.0$	2											
$c < 3.0, b < 0.5$	4											
$a < \text{Glass Thickness}$												
<p>07</p>	<p>Glass Chipping Except Pad Area: (Minor defect)</p> 	<table border="1"> <thead> <tr> <th>Length and Width</th> <th>Acc. Qty</th> </tr> </thead> <tbody> <tr> <td><math>c &gt; 3.0, b &lt; 1.0</math></td> <td>1</td> </tr> <tr> <td><math>c &lt; 3.0, b &lt; 1.0</math></td> <td>2</td> </tr> <tr> <td><math>c &lt; 3.0, b &lt; 0.5</math></td> <td>4</td> </tr> <tr> <td colspan="2"><math>a &lt; \text{Glass Thickness}</math></td> </tr> </tbody> </table>	Length and Width	Acc. Qty	$c > 3.0, b < 1.0$	1	$c < 3.0, b < 1.0$	2	$c < 3.0, b < 0.5$	4	$a < \text{Glass Thickness}$	
Length and Width	Acc. Qty											
$c > 3.0, b < 1.0$	1											
$c < 3.0, b < 1.0$	2											
$c < 3.0, b < 0.5$	4											
$a < \text{Glass Thickness}$												
<p>08</p>	<p>Glass Corner Chipping: (Minor defect)</p> 	<table border="1"> <thead> <tr> <th>Length and Width</th> <th>Acc. Qty</th> </tr> </thead> <tbody> <tr> <td><math>c &lt; 3.0, b &lt; 3.0</math></td> <td>Ignore</td> </tr> <tr> <td colspan="2"><math>a &lt; \text{Glass Thickness}</math></td> </tr> </tbody> </table>	Length and Width	Acc. Qty	$c < 3.0, b < 3.0$	Ignore	$a < \text{Glass Thickness}$					
Length and Width	Acc. Qty											
$c < 3.0, b < 3.0$	Ignore											
$a < \text{Glass Thickness}$												

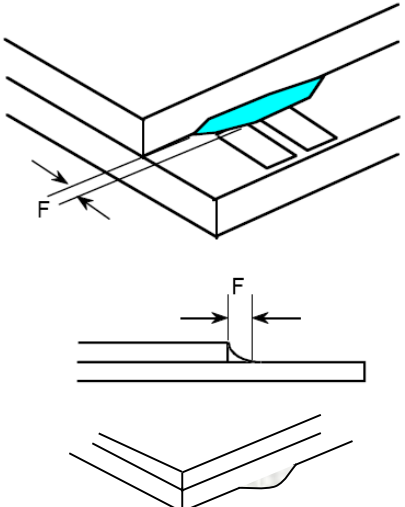
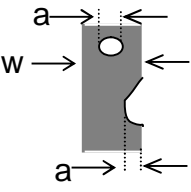

<p>09</p>	<p>Glass Burr: (Minor defect)</p> 	<table border="1" data-bbox="869 257 1340 347"> <thead> <tr> <th>Length</th> <th>Acc. Qty</th> </tr> </thead> <tbody> <tr> <td><math>F &lt; 1.0</math></td> <td>Ignore</td> </tr> </tbody> </table> <p>Glass burr don't affect assemble and module dimension.</p>	Length	Acc. Qty	$F < 1.0$	Ignore						
Length	Acc. Qty											
$F < 1.0$	Ignore											
<p>10</p>	<p>FPC Defect: (Minor defect)</p> 	<p>10.1 Dent, pinhole width <math>a &lt; w/3</math>. (w: circuitry width.)</p> <p>10.2 Open circuit is unacceptable.</p> <p>10.3 No oxidation, contamination and distortion.</p>										
<p>11</p>	<p>Bubble on Polarizer (Minor defect)</p>	<table border="1" data-bbox="742 1176 1212 1388"> <thead> <tr> <th>Diameter</th> <th>Acc. Qty</th> </tr> </thead> <tbody> <tr> <td><math>\varphi \leq 0.20</math></td> <td>Ignore</td> </tr> <tr> <td><math>0.20 &lt; \varphi \leq 0.30</math></td> <td>4</td> </tr> <tr> <td><math>0.30 &lt; \varphi \leq 0.50</math></td> <td>1</td> </tr> <tr> <td><math>0.50 &lt; \varphi</math></td> <td>None</td> </tr> </tbody> </table>	Diameter	Acc. Qty	$\varphi \leq 0.20$	Ignore	$0.20 < \varphi \leq 0.30$	4	$0.30 < \varphi \leq 0.50$	1	$0.50 < \varphi$	None
Diameter	Acc. Qty											
$\varphi \leq 0.20$	Ignore											
$0.20 < \varphi \leq 0.30$	4											
$0.30 < \varphi \leq 0.50$	1											
$0.50 < \varphi$	None											
<p>12</p>	<p>Dent on Polarizer (Minor defect)</p>	<table border="1" data-bbox="742 1433 1212 1646"> <thead> <tr> <th>Diameter</th> <th>Acc. Qty</th> </tr> </thead> <tbody> <tr> <td><math>\varphi \leq 0.20</math></td> <td>Ignore</td> </tr> <tr> <td><math>0.20 &lt; \varphi \leq 0.30</math></td> <td>4</td> </tr> <tr> <td><math>0.30 &lt; \varphi \leq 0.50</math></td> <td>1</td> </tr> <tr> <td><math>0.50 &lt; \varphi</math></td> <td>None</td> </tr> </tbody> </table>	Diameter	Acc. Qty	$\varphi \leq 0.20$	Ignore	$0.20 < \varphi \leq 0.30$	4	$0.30 < \varphi \leq 0.50$	1	$0.50 < \varphi$	None
Diameter	Acc. Qty											
$\varphi \leq 0.20$	Ignore											
$0.20 < \varphi \leq 0.30$	4											
$0.30 < \varphi \leq 0.50$	1											
$0.50 < \varphi$	None											
<p>13</p>	<p>Bezel</p>	<p>13.1 No rust, distortion on the Bezel.</p> <p>13.2 No visible fingerprints, stains or other contamination.</p>										
<p>14</p>	<p>PCB</p>	<p>14.1 No distortion or contamination on PCB terminals.</p> <p>14.2 All components on PCB must same as documented on the BOM/component layout.</p> <p>14.3 Follow IPC-A-600F.</p>										
<p>15</p>	<p>Soldering</p>	<p>Follow IPC-A-610C standard</p>										

16	Electrical Defect (Major defect)	The below defects must be rejected. 16.1 Missing vertical / horizontal segment, 16.2 Abnormal Display. 16.3 No function or no display. 16.4 Current exceeds product specifications. 16.5 LCD viewing angle defect. 16.6 No Backlight. 16.7 Dark Backlight. 16.8 Touch Panel no function.
----	----------------------------------	--

Remark: LCD Panel Broken shall be rejected. Defect out of LCD viewing area is acceptable.

**10.7. Classification of Defects**

- 10.7.1. Visual defects (Except no / wrong label) are treated as minor defect and electrical defect is major.
- 10.7.2. Two minor defects are equal to one major in lot sampling inspection.

**10.8. Identification/marketing criteria**

Any unit with illegible / wrong /double or no marking/ label shall be rejected.

**10.9. Packing**

- 10.9.1. There should be no damage of the outside carton box, each packaging box should have one identical label.
- 10.9.2. Modules inside package box should have compliant mark.
- 10.9.3. All direct package materials shall offer ESD protection.

**Note1:** Bright dot is defined as the defective area of the dot is larger than 50% of one sub-pixel area.

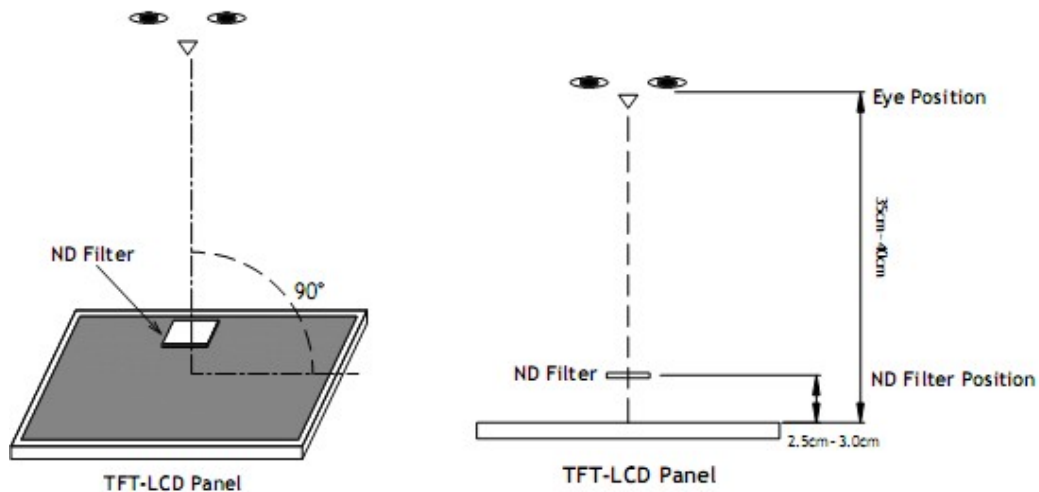

Bright dot: The bright dot size defect at black display pattern. It can be recognized by 2% transparency of filter when the distance between eyes and panel is 350mm± 50mm.

Dark dot: Cyan, Magenta or Yellow dot size defect at white display pattern. It can be recognized by 5% transparency of filter when the distance between eyes and panel is 350mm± 50mm.

**Note2:** Mura on display which appears darker / brighter against background brightness on parts of display area.

11. Reliability Specification

No	Item	Condition	Quantity	Criteria
1	High Temperature Operating	80°C, 96Hrs	2	GB/T2423.2-2008
2	Low Temperature Operating	-30°C, 96Hrs	2	GB/T2423.1-2008
3	High Humidity Storage	50°C, 90%RH, 96Hrs	2	GB/T2423.3-2016
4	High Temperature Storage	85°C, 96Hrs	2	GB/T2423.2-2008
5	Low Temperature Storage	-30°C, 96Hrs	2	GB/T2423.1-2008
6	Thermal Cycling Test Storage	-20°C, 60min~70°C, 60min, 20 cycles.	2	GB/T2423.22-2012
7	Packing vibration	Frequency range:10Hz~50Hz Acceleration of gravity:5G X, Y, Z 30 min for each direction.	-	GB/T5170.14-2009
8	Electrical Static Discharge	Air: ± 4KV 150pF/330 Ω 5 times	2	GB/T17626.2-2018
		Contact: ± 2KV 150pF/330 Ω 5 times		
9	Drop Test (Packaged)	Height:80 cm,1 corner, 3 edges, 6 surfaces.	-	GB/T2423.7-2018

Note1. No deflection cosmetic and operational function allowable.

Note2. Total current Consumption should be below double of initial value.

## 12. Precautions and Warranty

### 12.1. Safety

- 12.1.1. The liquid crystal in the LCD is poisonous. Do not put it in your mouth. If the liquid crystal touches your skin or clothes, wash it off immediately using soap and water.
- 12.1.2. Since the liquid crystal cells are made of glass, do not apply strong impact on them. Handle with care.

### 12.2. Handling

- 12.2.1. Reverse and use within ratings in order to keep performance and prevent damage.
- 12.2.2. Do not wipe the polarizer with dry cloth, as it might cause scratch. If the surface of the LCD needs to be cleaned, wipe it swiftly with cotton or other soft cloth soaked with petroleum IPA, do not use other chemicals.

### 12.3. Storage

- 12.3.1. Do not store the LCD module beyond the specified temperature ranges.
- 12.3.2. Strong light exposure causes degradation of polarizer and color filter.

### 12.4. Metal Pin (Apply to Products with Metal Pins)

#### 12.4.1. Pins of LCD and Backlight

12.4.1.1. Solder tip can touch and press on the tip of Pin LEAD during the soldering

#### 12.4.1.2. Recommended Soldering Conditions

Solder Type: Sn96.3~94-Ag3.3~4.3-Cu0.4~1.1

Maximum Solder Temperature: 370°C

Maximum Solder Time: 3s at the maximum temperature

Recommended Soldering Temp: 350±20°C

Typical Soldering Time: ≤3s

#### 12.4.1.3. Solder Wetting

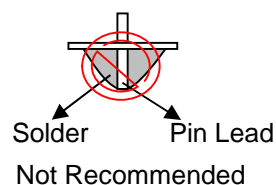
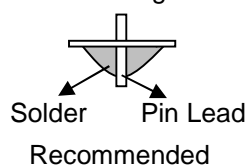

#### 12.4.2. Pins of EL

12.4.2.1. Solder tip can touch and press on the tip of EL leads during soldering.

12.4.2.2. No Solder Paste on the soldering pad on the motherboard is recommended.

#### 12.4.2.3. Recommended Soldering Conditions

Solder type: Nippon Alimit Leadfree SR-34, size 0.5mm

Recommended Solder Temperature: 270~290°C

Typical Soldering Time: ≤2s

Minimum solder distance from EL lamp (body):2.0mm

12.4.2.4. No horizontal press on the EL leads during soldering.

12.4.2.5. 180° bend EL leads three times is not allowed.

12.4.2.6. Solder Wetting

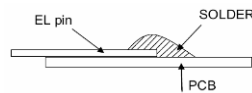

Recommended

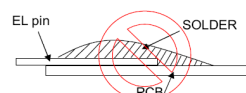

Not Recommended

12.4.2.7. The type of the solder iron:

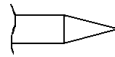

Recommended

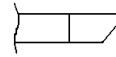

Not Recommended

12.4.2.8. Solder Pad

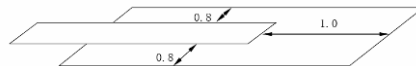

**12.5.Operation**

- 12.5.1. Do not drive LCD with DC voltage
- 12.5.2. Response time will increase below lower temperature
- 12.5.3. Display may change color with different temperature
- 12.5.4. Mechanical disturbance during operation, such as pressing on the display area, may cause the segments to appear “fractured”.
- 12.5.5. Do not connect or disconnect the LCM to or from the system when power is on.
- 12.5.6. Never use the LCM under abnormal condition of high temperature and high humidity.
- 12.5.7. Module has high frequency circuits. Sufficient suppression to the electromagnetic interface shall be done by system manufacturers. Grounding and shielding methods may be important to minimize the interference.
- 12.5.8. *Do not display the fixed pattern for long time (we suggest the time not longer than one hour) because it will develop image sticking due to the TFT structure.*

**12.6.Static Electricity**

- 12.6.1. CMOS LSIs are equipped in this unit, so care must be taken to avoid the electro-static charge, by ground human body, etc.
- 12.6.2. The normal static prevention measures should be observed for work clothes and benches.
- 12.6.3. The module should be kept into anti-static bags or other containers resistant to static for storage.

**12.7.Limited Warranty**

- 12.7.1. Our warranty liability is limited to repair and/or replacement. We will not be responsible for any consequential loss.
- 12.7.2. If possible, we suggest customer to use up all modules in six months. If the module storage time over twelve months, we suggest that recheck it before the module be used
- 12.7.3. . After the product shipped, any product quality issues must be feedback within three months, otherwise, we will not be responsible for the subsequent or consequential events.

13. Outline Drawing

