

**DISPLAY Elektronik GmbH**

# DATA SHEET

**LCD MODULE**

**DEM 240064C2 SYH-LY**

*Product Specification*

*Version: 0*

**11.01.2024**

# GENERAL SPECIFICATION

---

MODULE NO. :

# DEM 240064C2 SYH-LY

CUSTOMER P/N

VERSION NO.	CHANGE DESCRIPTION	DATE
0	Original Version	11.01.2024

PREPARED BY: CC

DATE: 11.01.2024

APPROVED BY: WH

DATE: 11.01.2024

**CONTENTS**

**1. FUNCTIONS & FEATURES ..... 2**

**2. MODULE ARTWORK ..... 2**

**3. EXTERNAL DIMENSIONS ..... 3**

**4. BLOCK DIAGRAM..... 4**

**5. PIN ASSIGNMENT..... 4**

**6. POWER SUPPLY ..... 5**

**7. PCB DRAWING AND DESCRIPTION ..... 6**

**8. ABSOLUTE MAXIMUM RATINGS ..... 7**

**9. ELECTRICAL CHARACTERISTICS ..... 7**

**10. ELECTRONIC-OPTICAL CHARACTERISTICS..... 9**

**11. BACKLIGHT ELECTRICAL/OPTICAL SPECIFICATIONS ..... 11**

**12. PRECAUTION FOR USING LCM..... 12**

**13. THE MODULE ACCEPT QUALITY LEVEL (AQL) ..... 13**

**14. RELIABILITY TEST..... 14**

**15. LCD MODULES HANDLING PRECAUTIONS ..... 15**

**16. OTHERS..... 15**

**1. FUNCTIONS & FEATURES**

- LCD TYPE:

Module Model	LCD Type
DEM 240064C2 SYH-LY	STN Yellow-Green Transflective Positive Mode

- Viewing Direction : 6 O'clock
- Driving Scheme : 1/64 Duty, 1/9 Bias
- Power Supply for logic : 5.0 Volt (typ.)
- Display Content : 240 x 64 Dots
- $V_{LCD}$  : 12.6 Volt (typ.)
- Operation Temperature : -20°C to 70°C
- Storage temperature : -30°C to 80°C
- ROHS : Conformed

**2. MODULE ARTWORK**

- Module Size : 180.00 x 65.00 x 16.00 mm
- Dot Size : 0.49 x 0.49 mm
- Dot Gap : 0.04 mm

3. EXTERNAL DIMENSIONS

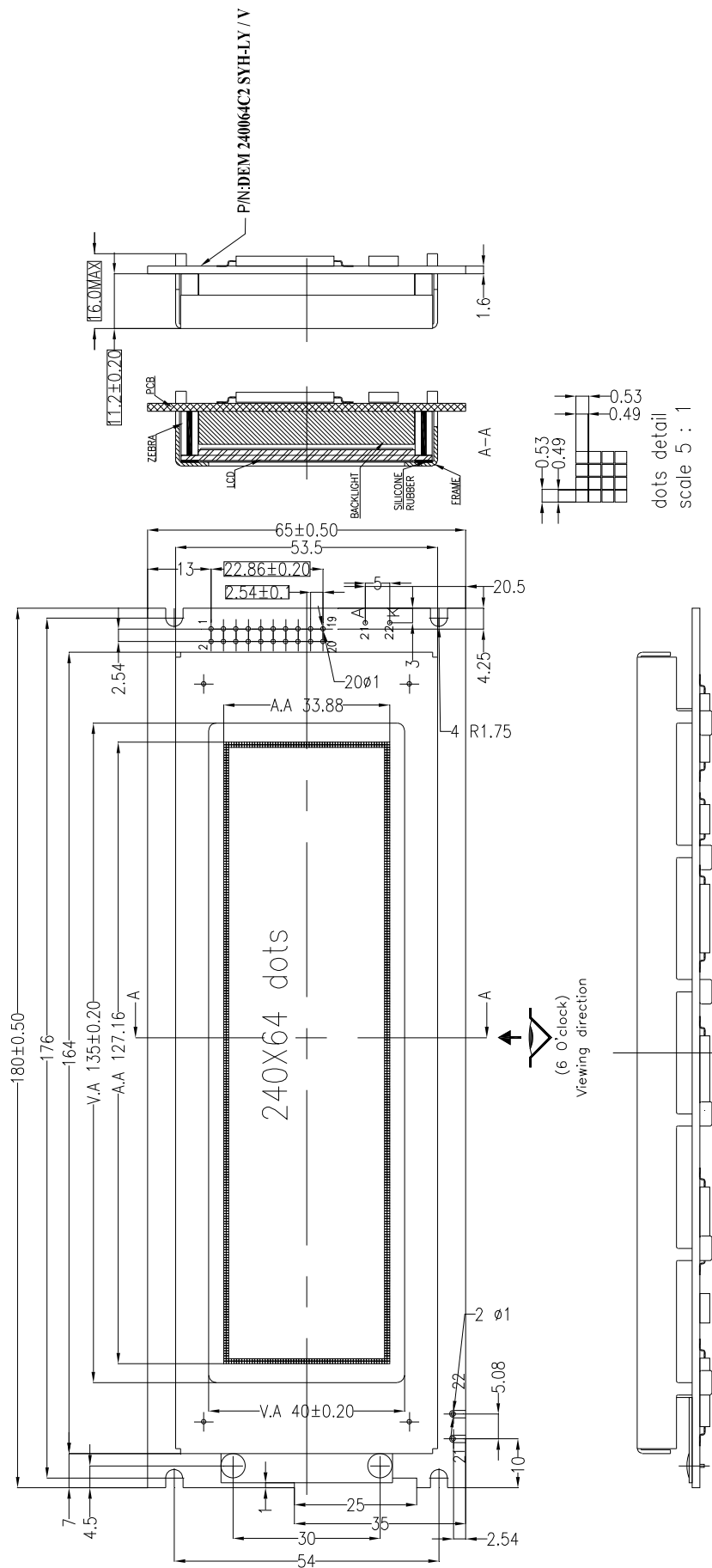

REMARKS:  
 1. UNMARKED TOLERANCE IS ±0.20  
 2. MATERIAL COMPLY WITH THE ROHS.

4. BLOCK DIAGRAM

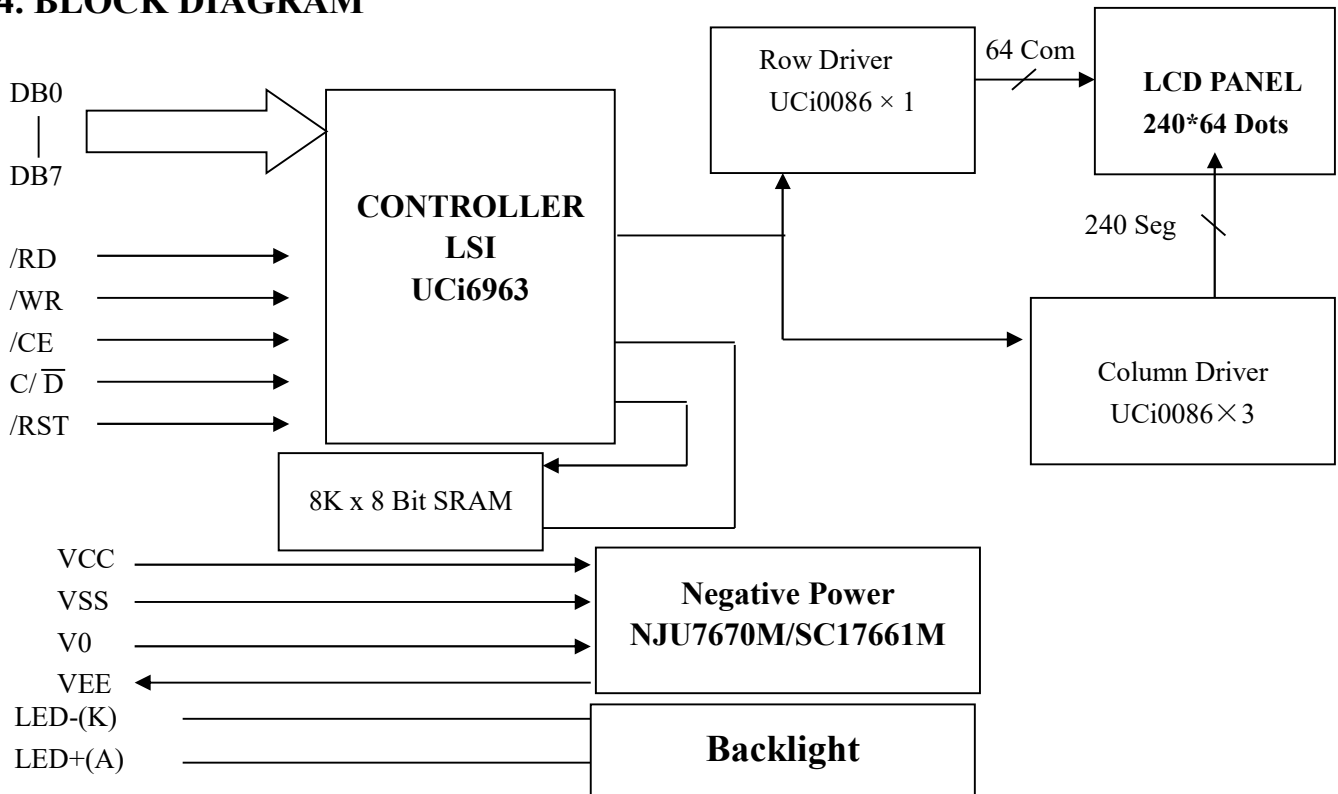

5. PIN ASSIGNMENT

NO.	SYMBOL	FUNCTION
1	FG	Frame ground
2	VSS	Ground (0V)
3	VDD	Power Supply(+5V)
4	V0	Power Supply for LCD Drive
5	/WR	Data write. Write data to controller UCi6963 when “L”
6	/RD	Data read. Read data from controller UCi6963 when “L”
7	CE	Chip enable of controller when “L”
8	C/ /D	Command/Data read/write. “H” for command read/write and “L” for data read/write
9	VEE	The negative power supply for LCD
10	/RST	Controller reset when “L”
11	DB0	Data input/output(LSB)
12	DB1	Data input/output
13	DB2	Data input/output
14	DB3	Data input/output
15	DB4	Data input/output
16	DB5	Data input/output
17	DB6	Data input/output
18	DB7	Data input/output(MSB)
19	FS	Font select. “H” for 6x8 font & “L” for 8x8 font
20	N.C	No Connection
21	LED+(A)	Anode of LED backlight
22	LED-(K)	Cathode of LED backlight

**6. POWER SUPPLY**

**Mode (Internal Contrast Regulation) - J7 is closed.**

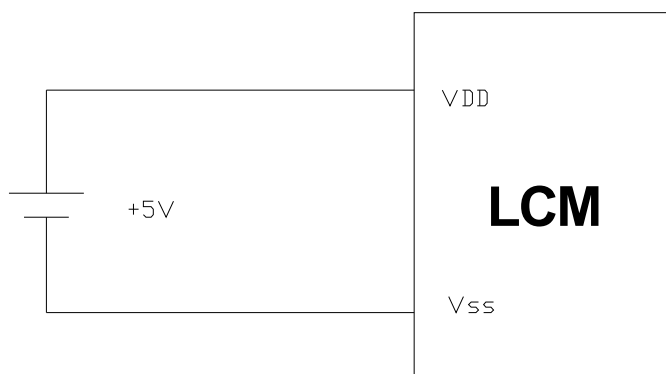

**Mode (External Contrast Regulation) - J7 is open.**

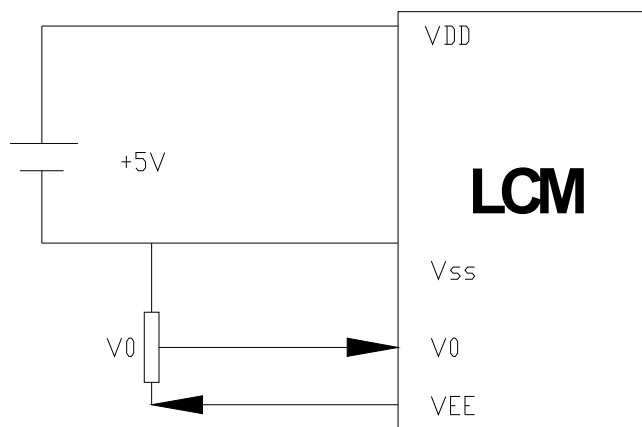

**7. PCB DRAWING AND DESCRIPTION**

**7.1 PCB DRAWING**

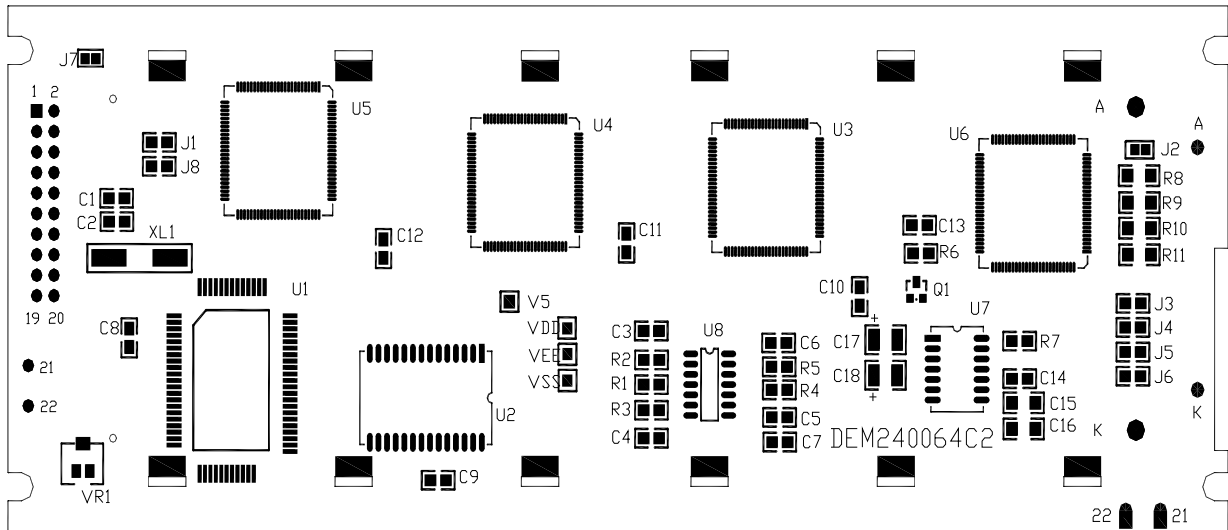

**7.2 DESCRIPTION:**

7-2-1. The polarity of the pin 21 and the pin 22:

J3, J5	J4, J6	LED Polarity	
		21 Pin	22 Pin
Each open	Each closed	Anode	Cathode
Each closed	Each open	Cathode	Anode

Note: In application module, J3=J5= open, J4=J6=0 Ohm

7-2-2. The metal-bezel is set on ground when the J1= 0 Ohm and the mounting holes are set on ground when J8= 0 Ohm.

Note: In application module, J1=J8= 0 Ohm

7-2-3. The LED resistor can be bridged when the J2 =0 Ohm

Note: In application module, J2=open

7-2-4. The R8, R9, R10 and the R11 are the LED resistor.

Note: In application module, R8=R9=R10=R11=6.2 Ohm

7-2-5. The module use internal contrast regulation when J7 = 0 Ohm.

Note: In application module, J7 is open, but potentiometer is calibrated by the factory.

7-2-6 The VR1 use internal contrast regulation.

Note: In application module, VR1=10k Ohm



**8. ABSOLUTE MAXIMUM RATINGS**

( V<sub>SS</sub>=0V, Ta=25°C)

PARAMETER	SYMBOL	Min.	Max.	UNIT	Remark
Supply Voltage (Logic)	V <sub>DD</sub>	-0.3	7	V	---
Input Voltage Range	V <sub>I</sub>	-0.3	V <sub>DD</sub> +0.3	V	---
Operating Temperature	V <sub>OP</sub>	-20	+70	°C	---
Storage Temperature	V <sub>STO</sub>	-30	+80	°C	---

**9. ELECTRICAL CHARACTERISTICS**

**9.1. DC Characteristics**

(V<sub>SS</sub>=0V, Ta=25°C)

Parameter	Symbol	Conditions	Min.	Typ.	Max.	Units
Supply Voltage (Logic)	V <sub>DD</sub>	-	4.5	5.0	5.5	V
Supply Voltage for LCD driver	V <sub>LCD</sub>	-	12.3	12.6	12.9	V
Current Consumption	I <sub>DD</sub>	V <sub>DD</sub> =5.0V	--	TBD	--	mA

**9.2. AC Characteristics**

( V<sub>SS</sub>=0V, Ta=25°C)

Parameter	Symbol	Min.	Max.	Units
C/D Setup Time	t <sub>CDS</sub>	100	-	ns
C/D Hold Time	t <sub>CDH</sub>	10	-	ns
CE, RD, WR Pulse Width	t <sub>CE</sub> , t <sub>RD</sub> , t <sub>WR</sub>	80	-	ns
Data Setup Time	t <sub>DS</sub>	80	-	ns
Data Hold Time	t <sub>DH</sub>	40	-	ns
Access Time	t <sub>ACC</sub>	-	150	ns
Output Hold Time	t <sub>OH</sub>	10	50	ns

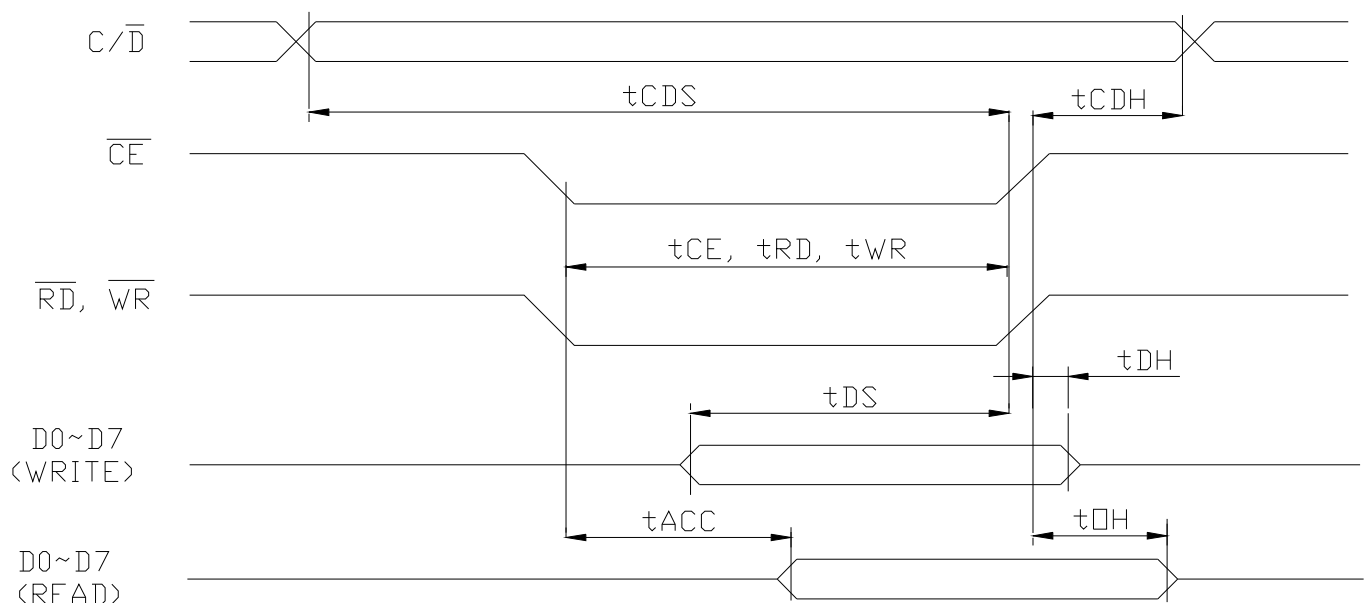

9.3. Power Supply ON/OFF Sequence

● ON Sequence

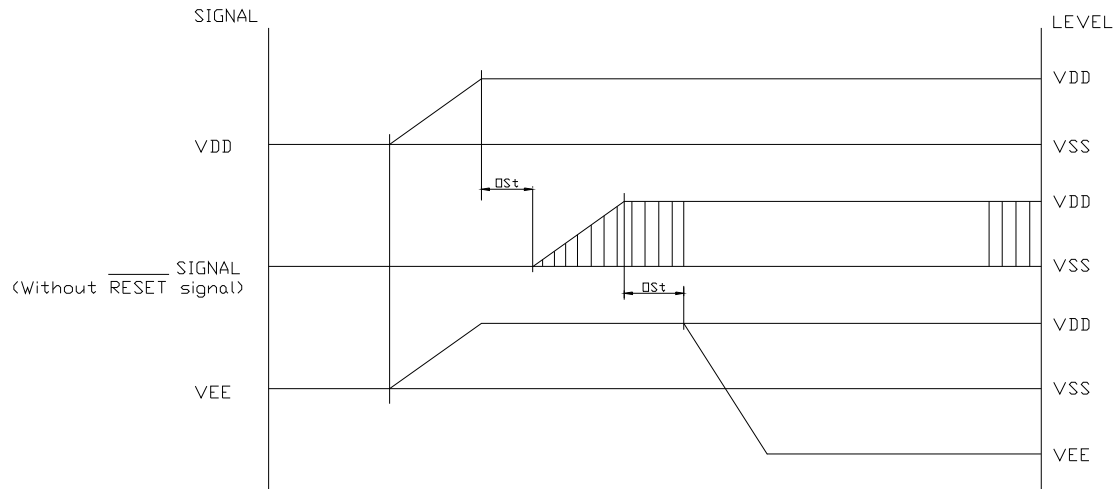

● OFF Sequence

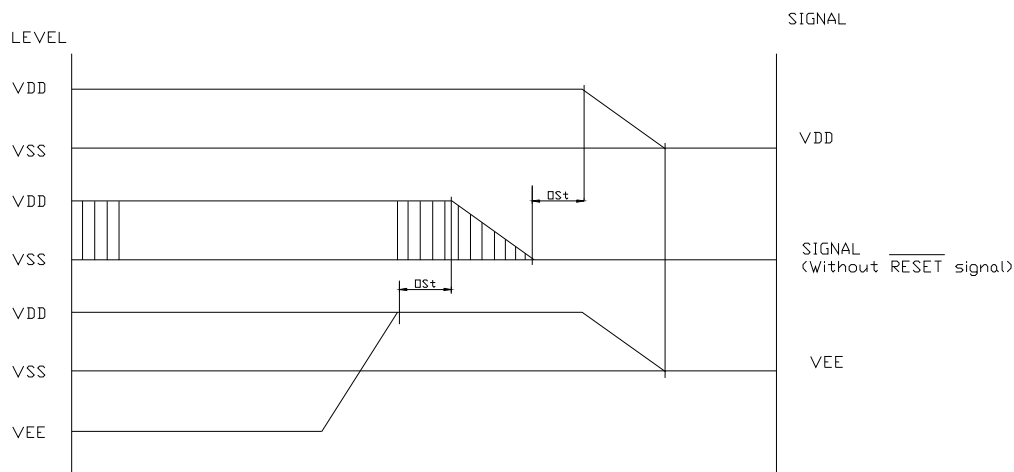

● Reset Sequence

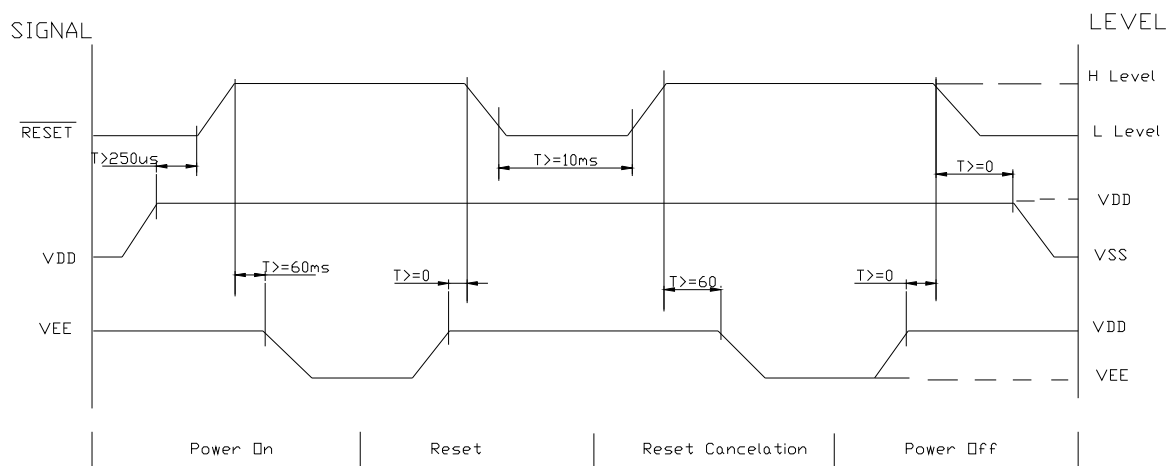

Please maintain the above sequence when turning on and off the power supply of the module.

If VEE is supplied to the module while internal alternate signal for LCD driving (M) is unstable or RESET is active, DC component will be supplied to the LCD panel. This may cause damage to the LCD module.

**10. ELECTRONIC-OPTICAL CHARACTERISTICS**

ITEM	SYMBOL	CONDITION	MIN.	TYP.	MAX.	UNIT	REF.
Rise Time	Tr	0°C	---	450	560	ms	Note(1)
		25°C		140	210		
Fall Time	Tf	0°C	----	680	800	ms	
		25°C		220	330		
Contrast	CR	25°C	---	2.7	---		Note(3)
View Angle	θ 1 • θ 2 φ 1 • φ 2	25°C & CR ≥ 1.5	--	--	80		Note(2)
			-35	--	35		
Frame Frequency	Ff	25°C	--	64	--	Hz	

Note (1) & (2) : See next page

Note(3) : Contrast ratio is defined under the following condition: CR=

Brightness of no-selected condition

Brightness of selected condition

- (a). Temperature -----25°C
- (b). Frame frequency -----64Hz
- (c). viewing angle ----- θ =0° , φ =0°
- (d). Operating voltage-----12V

Note (1) Response time is measured as the shortest period of time possible between the change is state of an LCD segment as demonstrated below: entire range.

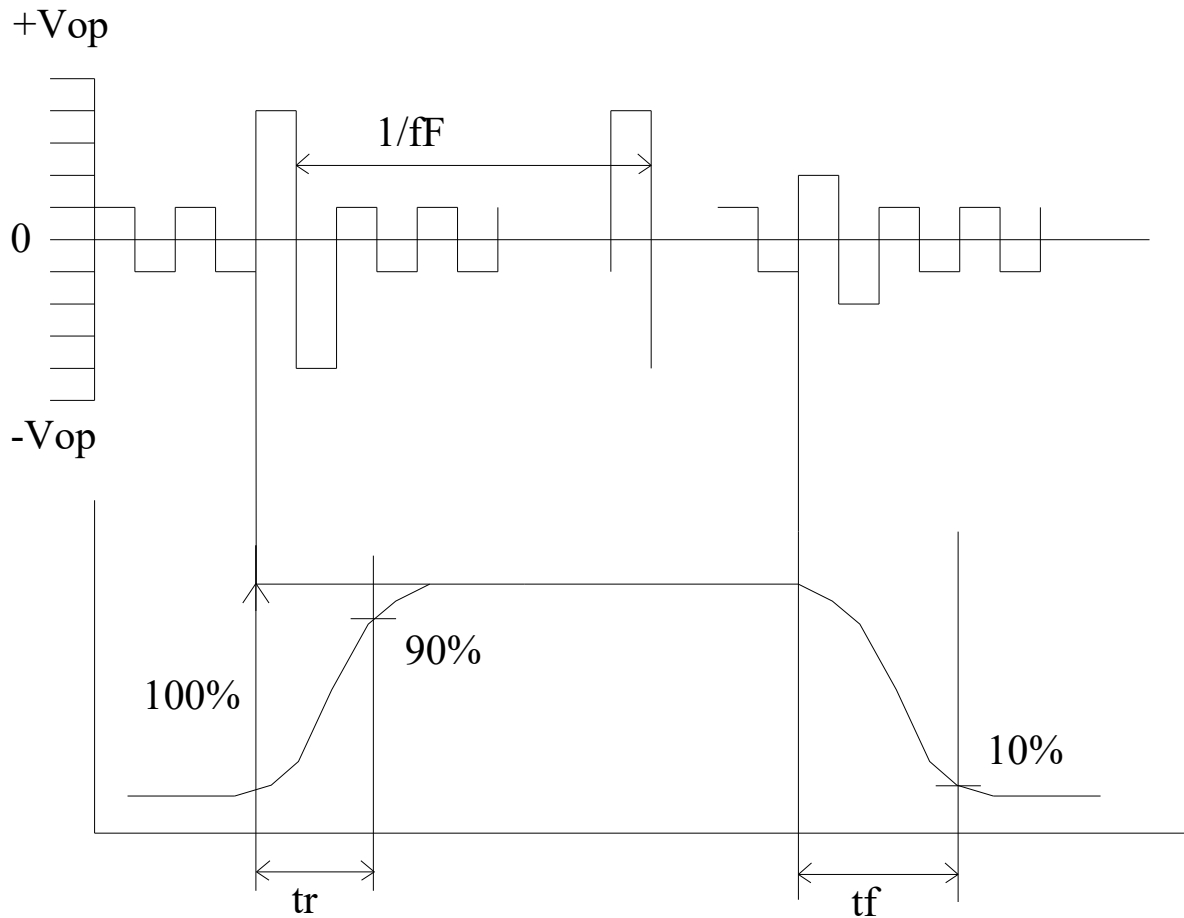

Condition:

- (a) .Temperature-----25 °C
- (b).Frame frequency-----64Hz
- (c). View Angle-----  $\theta = 0^\circ$  ,  $\phi = 0^\circ$
- (d). Operating voltage-----12V

Note(2) definition of View Angle

Top --bottom direction

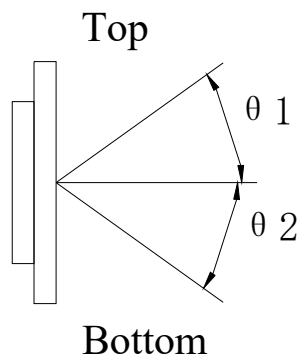

Right --left direction

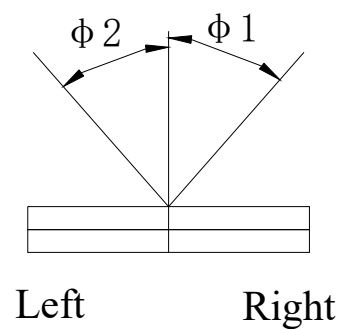

**11. BACKLIGHT ELECTRICAL/OPTICAL SPECIFICATIONS**

Electrical/Optical Specifications:

ITEM	SYMBOL	MIN.	TYP.	MAX.	UNIT	CONDITIONS
Forward Voltage	V <sub>f</sub>	3.8	4.0	4.2	V	I <sub>f</sub> = 450mA
Reverse Current	I <sub>R</sub>	---	---	0.69	mA	V <sub>R</sub> =10V
Luminous Intensity	I <sub>v</sub>	100	120		cd/m <sup>2</sup>	I <sub>f</sub> = 450mA
Emission wavelength	λ <sub>p</sub>	567	571	575	nm	I <sub>f</sub> = 450mA
Spectral line half width	Δλ	---	30	---	nm	I <sub>f</sub> = 450mA
Luminous Uniformity		75	---	---	%	I <sub>f</sub> = 450mA

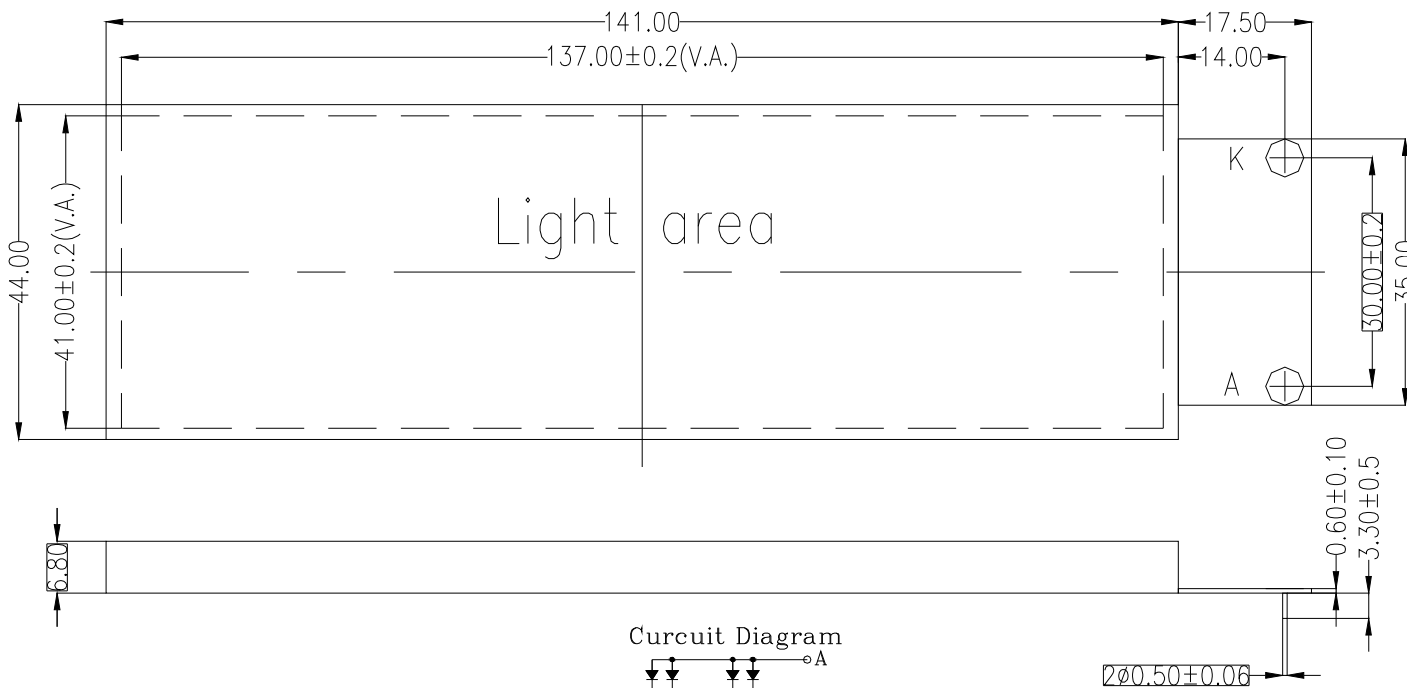

REMARKS:  
 1.UNMARKED TOLERANCE IS ±0.3  
 2.ALL MATERIAL COMPLY WITH ROHS.

**12. PRECAUTION FOR USING LCM****1. LIQUID CRYSTAL DISPLAY (LCD)**

LCD is made up of glass, organic sealant, organic fluid, and polymer based polarizer. The following precautions should be taken when handling,

- (1). Keep the temperature within range of use and storage. Excessive temperature and humidity could cause polarization degradation, polarizer peel off or bubble.
- (2). Do not contact the exposed polarizer with anything harder than an HB pencil lead. To clean dust off the display surface, wipe gently with cotton, chamois or other soft material soaked in petroleum benzine.
- (3). Wipe off saliva or water drops immediately. Contact with water over a long period of time may cause polarizer deformation or color fading, while an active LCD with water condensation on its surface will cause corrosion of ITO electrodes.
- (4). Glass can be easily chipped or cracked from rough handling, especially at corners and edges.
- (5). Do not drive LCD with DC voltage.

**2. Liquid Crystal Display modules****2.1 Mechanical considerations**

LCM are assembled and adjusted with a high degree of precision. Avoid excessive shocks and do not make any alterations or modifications. The following should be noted.

- (1). Do not tamper in any way with the tabs on the metal frame
- (2). Do not modify the PCB by drilling extra holes, changing its outline, moving its components or modifying its pattern.
- (3). Do not touch the elastomer connector, especially insert a backlight panel (for example, EL).
- (4). When mounting a LCM make sure that the PCB is not under any stress such as bending or twisting. Elastomer contacts are very delicate and missing pixels could result from slight dislocation of any of the elements.
- (5). Avoid pressing on the metal bezel, otherwise the elastomer connector could be deformed and lose contact, resulting in missing pixels.

**2.2. Static Electricity**

LCM contains CMOS LSI's and the same precaution for such devices should apply, namely

- (1). The operator should be grounded whenever he/she comes into contact with the module. Never touch any of the conductive parts such as the LSI pads, the copper leads on the PCB and the interface terminals with any parts of the human body.
- (2). The modules should be kept in antistatic bags or other containers resistant to static for storage.
- (3). Only properly grounded soldering irons should be used.
- (4). If an electric screwdriver is used, it should be well grounded and shielded from commutator sparks.
- (5). The normal static prevention measures should be observed for work clothes and working benches; for the latter conductive (rubber) mat is recommended.
- (6). Since dry air is inductive to static, a relative humidity of 50-60% is recommended.

**2.3. Soldering**

- (1). Solder only to the I/O terminals.
- (2). use only soldering irons with proper grounding and no leakage.
- (3). Soldering temperature:  $280^{\circ}\text{C} \pm 10^{\circ}\text{C}$
- (4). Soldering time: 3 to sec.
- (5). Use eutectic solder with resin flux fill.
- (6). If flux is used, the LCD surface should be covered to avoid flux spatters. Flux residue should be removed afterwards.

**2.4 Operation**

- (1). The viewing angle can be adjusted by varying the LCD driving voltage V0.
- (2). Driving voltage should be kept within specified range; excess voltage shortens display life.
- (3). Response time increases with decrease in temperature.
- (4). Display may turn black or dark blue at temperatures above its operational range; this is (however not pressing on the viewing area) may cause the segments to appear “fractured”.
- (5). Mechanical disturbance during operation (such as pressing on the viewing area) may cause the segments to appear “fractured”.

**2.5 Storage**

If any fluid leaks out of a damaged glass cell, wash off any human part that comes into contact with soap and water. Never swallow the fluid. The toxicity is extremely low but caution should be exercised at all the time.

**2.6 Limited Warranty**

Unless otherwise agreed between DISPLAY and customer, DISPLAY will replace or repair any of its LCD and LCM which is found to be defective electrically and visually when inspected in accordance with DISPLAY acceptance standards, for a period on one year from date of shipment. Confirmation of such date shall be based on freight documents. The warranty liability of DISPLAY is limited to repair and/or replacement on the terms set forth above. DISPLAY will not responsible for any subsequent or consequential events.

**13. THE MODULE ACCEPT QUALITY LEVEL (AQL)**

**13.1 AQL Standard Value: Fatal Defect =0.1, Major Defect=0.65; Minor Defect =2.5.**

**13.2 Curtailed Inspection Scheme**

Type	Batch Qty	inspection Qty	AQL value	pass	Reject
module product	350PCS< 1000PCS	125pcs	0.1	0	1
			0.65	2	3
			2.5	7	8
	200PCS< 350PCS	80pcs	0.1	0	1
			0.65	1	2
			2.5	5	6
	<200PCS	32pcs	0.1	0	1
			0.65	0	1
			2.5	4	5
Module sample	<200PCS	All inspected	/	/	The sample will be reject when the fateful defect>2pcs or main defect>5pcs.
	>200PCS	125pcs			

- Notes:**
- 1). Batch QTY is the production amount that Production department ship to QA department.
  - 2). All of product will be inspected if the batch QTY less than inspected QTY.
  - 3). Each batch fixed to be 500pcs.

**14. RELIABILITY TEST**

Operating life time: Longer than 50000 hours (at room temperature without direct irradiation of sunlight)

Reliability characteristics shall meet following requirements.

TEMPERATURE TESTS	NORMAL GRADE
High Temperature Storage	+75°C * 96hrs
Low Temperature Storage	-25°C * 96hrs
High Temperature Operation	+70°C * 96hrs
Low Temperature Operation	-20°C * 96hrs
High Temperature, High Humidity	+70°C 95%RH 96hrs
Thermal Shock	-20°C * 30 min ← 10s ↓ 5Cycles +70°C * 30 min
Vibration Test	Frequency * Swing * Time 40Hz * 4mm * 4hrs
Drop Test	Drop height * Times 1.0m * 6 times



**15. LCD MODULES HANDLING PRECAUTIONS**

- Please remove the protection foil of polarizer before using.
- The display panel is made of glass. Do not subject it to a mechanical shock by dropping it from a high place, etc.
- If the display panel is damaged and the liquid crystal substance inside it leaks out, do not get any in your mouth. If the substance come into contact with your skin or clothes promptly wash it off using soap and water.
- Do not apply excessive force to the display surface or the adjoining areas since this may cause the color tone to vary.
- The polarizer covering the display surface of the LCD module is soft and easily scratched. Handle this polarize carefully.
- To prevent destruction of the elements by static electricity, be careful to maintain an optimum work environment.
  - Be sure to ground the body when handling the LCD module.
  - Tools required for assembly, such as soldering irons, must be properly grounded.
  - To reduce the amount of static electricity generated, do not conduct assembly and other work under dry conditions.
  - The LCD module is coated with a film to protect the display surface. Exercise care when peeling off this protective film since static electricity may be generated.
- Storage precautions  
When storing the LCD modules, avoid exposure to direct sunlight or to the light of fluorescent lamps. Keep the modules in bags designed to prevent static electricity charging under low temperature / normal humidity conditions (avoid high temperature / high humidity and low temperatures below 0°C). Whenever possible, the LCD modules should be stored in the same conditions in which they were shipped from our company.

**16. OTHERS**

- Liquid crystals solidify at low temperature (below the storage temperature range) leading to defective orientation of liquid crystal or the generation of air bubbles (black or white). Air bubbles may also be generated if the module is subjected to a strong shock at a low temperature.
- If the LCD modules have been operating for a long time showing the same display patterns may remain on the screen as ghost images and a slight contrast irregularity may also appear. Abnormal operating status can be resumed to be normal condition by suspending use for some time. It should be noted that this phenomena does not adversely affect performance reliability.
- To minimize the performance degradation of the LCD modules resulting from caused by static electricity, etc. exercise care to avoid holding the following sections when handling the modules:
  - Exposed area of the printed circuit board
  - Terminal electrode sections