

Display Elektronik GmbH

DATA SHEET

TFT MODULE

DEM 19201080I VM-PW-N

15,6“ TFT

Product Specification

Version: 0

13.12.2024

Contents

1. Block Diagram	5
2. Outline dimension	6
3. Input terminal Pin Assignment	7
3.1 Driving interface of PWB	7
3.2 eDP interface	9
4. LCD Optical Characteristics	10
4.1 Optical specification	10
5. Electrical Characteristics	13
5.1 Absolute Maximum Rating	13
5.2 DC Electrical Characteristics	13
5.3 LED Backlight Characteristics	14
6. Display Port Input Signal Timing Specifications	16
6.1 Timing Characteristics	16
6.2 eDP Rx Interface Timing Parameter	17
6.3 Color Data Input Assignment	18
6.4 Power ON/OFF Sequence	19
6.5 EDID Specifications (TBD)	20
7. LCD Module Out-Going Quality Level	24
7.1 VISUAL & FUNCTION INSPECTION STANDARD	24
7.1.1 Inspection conditions	24
7.1.2 DefinitionZone D	24
7.1.3 Sampling Plan	25
7.1.4 Criteria (Visual)	26
8. Reliability Test Result	30
9. Cautions and Handling Precautions	31
9.1 Handling and Operating the Module	31
9.2 Storage and Transportation.	31

*** Description**

This is a color active matrix TFT (Thin Film Transistor) LCD (liquid crystal display) that uses amorphous silicon TFT as a switching device. This model is composed of a Transmissive type TFT-LCD Panel, driver circuit, back-light unit. The resolution of a 15.6" TFT-LCD contains 1920X1080 pixels, and can display up to 16.7 colors. The TFT-LCD panel used for this FOB is a low reflection and higher color type. All input signals are eDP1.2 interface compatible.

*** Features**

General Information Items	Specification	Unit	Note
	Main Panel		
Display area(AA)	344.16(H)*193.59(V) (15.6inch)	mm	
Driver element	TFT active matrix	-	
Display colors	16.7M	colors	
Number of pixels	1920(RGB)*1080	dots	
Pixel arrangement	RGB vertical stripe	-	
Pixel pitch	0.17925(H)*0.17925(V)	mm	
Viewing angle	ALL	o'clock	
Display mode	Normally Black	-	
Surface treatment of front polarizer	Anti-glare coating: (3H)	-	
Operating temperature	0~+50	°C	
Storage temperature	-20~+60	°C	

- 2 lane eDP Interface with 2.7Gbps Link Rates
- Thin and light weight
- 8-bit color depth, display 16.7M colors
- Single LED Lighting Bar. (Down side/Horizontal Direction)
- Green Product (RoHS & Halogen free product)
- On board LED Driving circuit
- Low driving voltage and low power consumption
- On board EDID chip

* Mechanical Information

Item		Min.	Typ.	Max.	Unit	Note
Module size	Horizontal(H)	-	350.72	-	mm	
	Vertical(V)	-	204.96	-	mm	
	Depth(D)	-	2.9	-	mm	
Weight		-	454	-	g	

1. Block Diagram

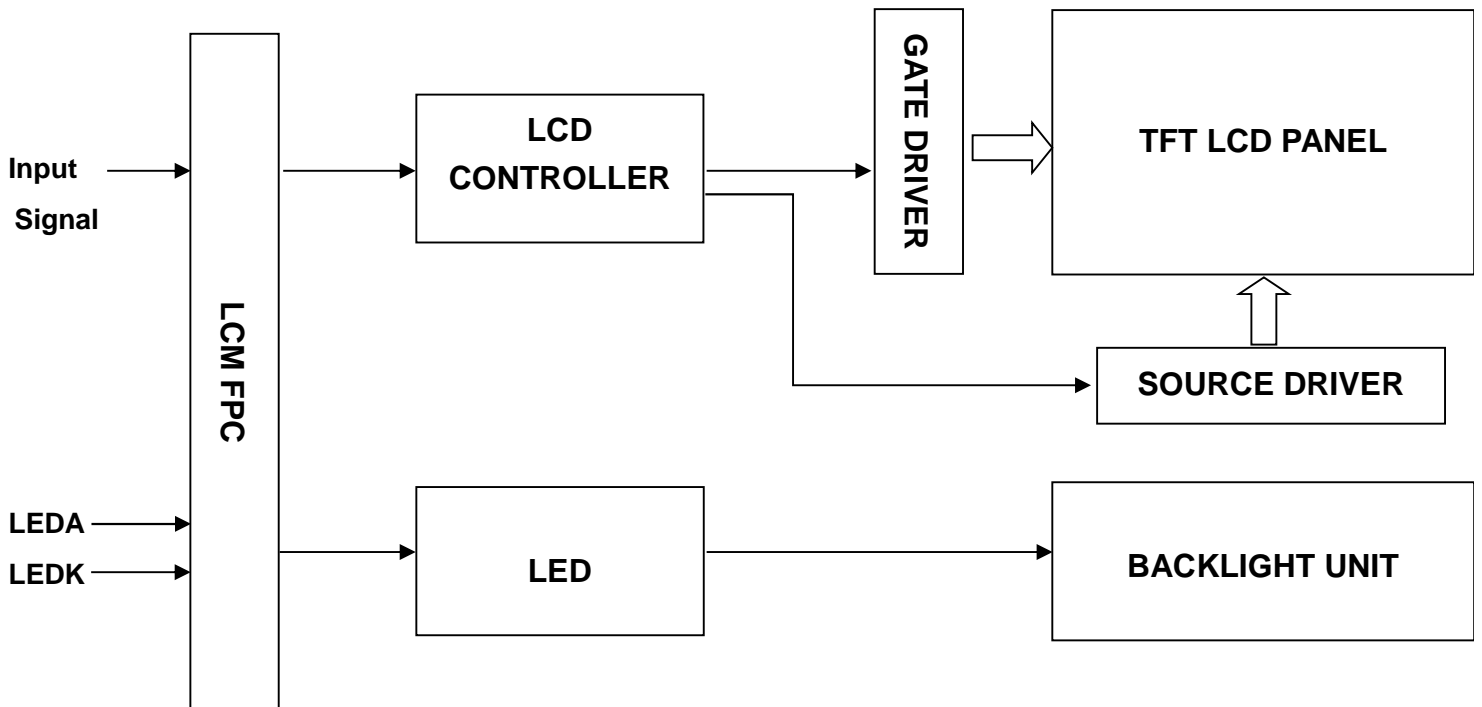

2. Outline dimension

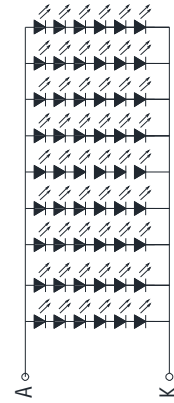
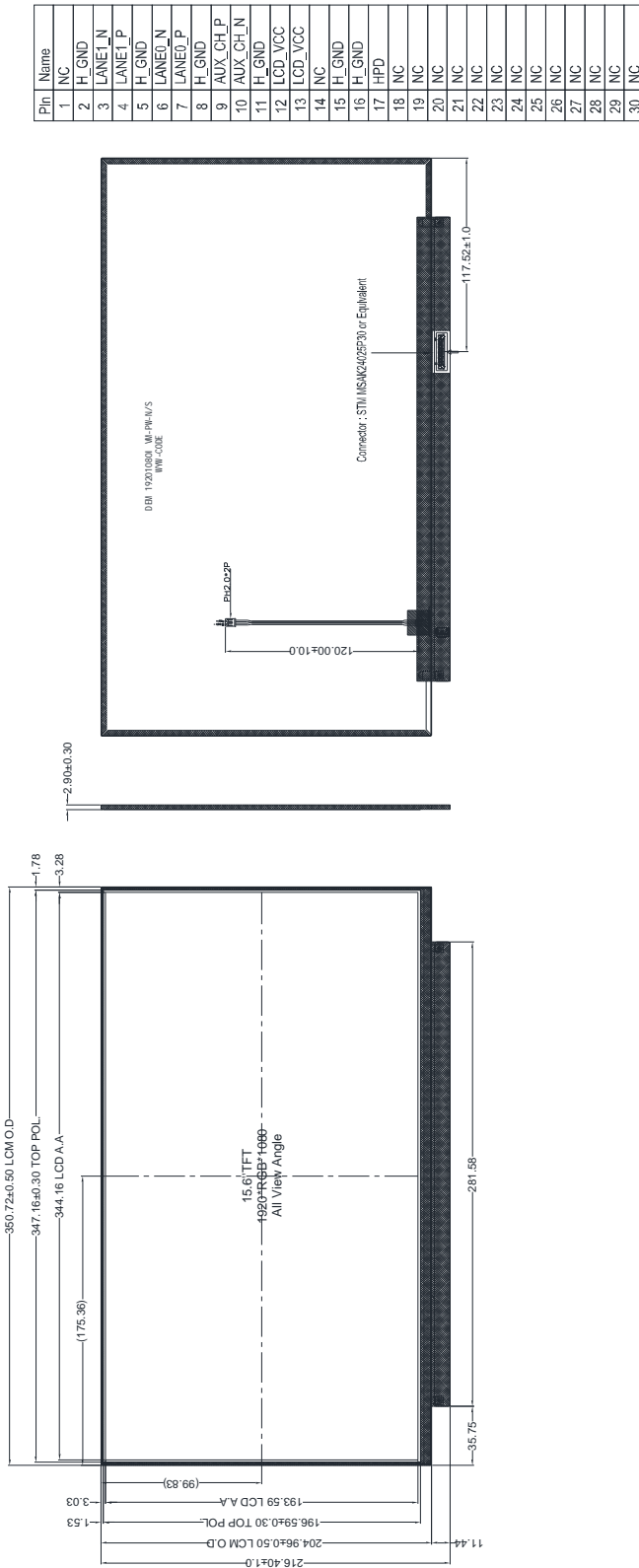

Backlight LED 6*9=54EA Circuit

LED(B/L) CIRCUIT

- NOTES:
1. DISPLAY TYPE: 15.6", TFT LCD, 16.7M COLORS
 2. DISPLAY MODE: NORMALLY BLACK, IPS
 3. VIEWING DIRECTION: FREE
 4. TFT INTERFACE: 2 lane eDP
 5. LCD_VCC: 3.3V
 6. OPERATING TEMP: 0°C TO 50°C
STORAGE TEMP: -20°C TO 60°C
 7. LCM BRIGHTNESS: 500cd/m²(Typ.)
 8. BACK LIGHT: LED WHITE, 54 LED, 180mA, 33.6~36.0V
 9. RoHS AND REACH COMPLIANT.

3. Input terminal Pin Assignment

3.1 Driving interface of PWB

NO.	SYMBOL	DISCRIPTION	I/O
1	NC	No Connection	--
2	H_GND	Ground	P
3	LAN1_N	eDP RX channel 1 negatives	I
4	LAN1_P	eDP RX channel 1 positive	I
5	H_GND	Ground	P
6	LAN0_N	eDP RX channel 0 negative	I
7	LAN0_P	eDP RX channel 0 positive	I
8	H_GND	Ground	P
9	AUXCH_P	eDP AUX CH positive	I
10	AUXCH_N	eDP AUX CH negative	I
11	H_GND	Ground	P
12	LCD_VCC	Power Supply,3.3V(typ.)	I
13	LCD_VCC	Power Supply,3.3V(typ.)	I
14	NC	No Connection	--
15	H_GND	Ground	P
16	H_GND	Ground	P
17	HPD	HPD signal pin	I
18	NC	No Connection	--
19	NC	No Connection	--
20	NC	No Connection	--
21	NC	No Connection	--
22	NC	No Connection	--
23	NC	No Connection	--
24	NC	No Connection	--
25	NC	No Connection	--
26	NC	No Connection	--

27	NC	No Connection	--
28	NC	No Connection	--
29	NC	No Connection	--
30	NC	No Connection	--

The electronics interface connector is UJU IS050-L30B-C10 or Compatible.

Mating housing/ Part Number: I-PEX 20454-030T or Compatible

CN1 pin 1 position



3.2 eDP interface

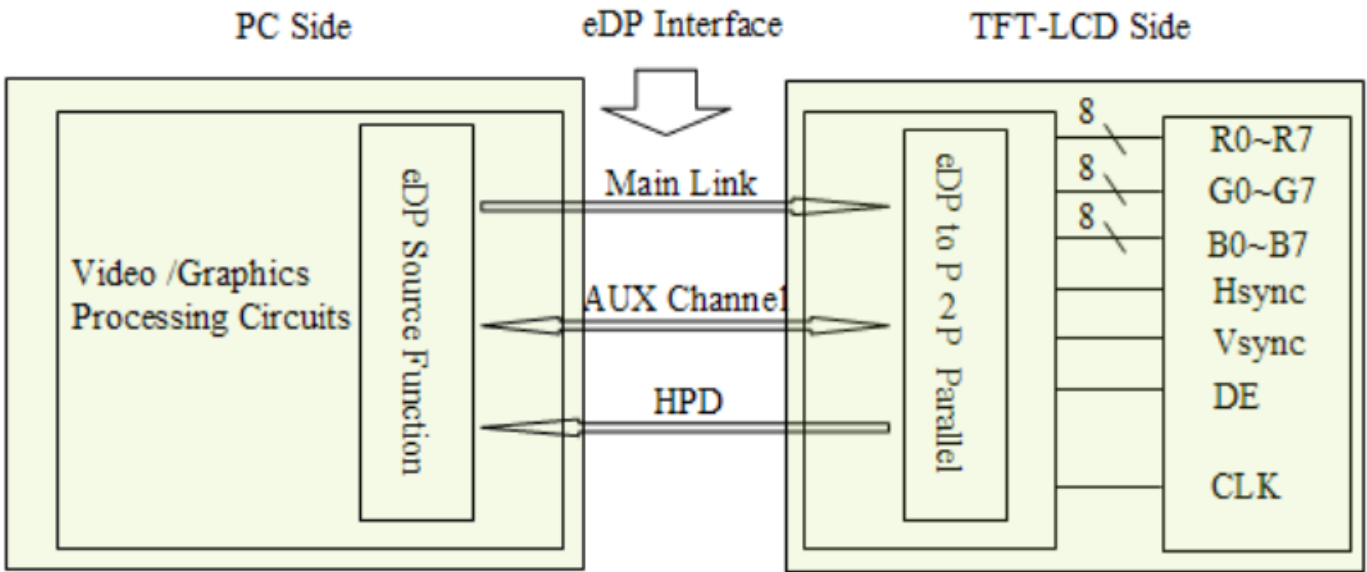

Lane 0	Lane 1
R0-7:0	R1-7:0
G0-7:0	G1-7:0
B0-7:0	B1-7:0
R2-7:0	R3-7:0
G2-7:0	G3-7:0
B2-7:0	B3-7:0
R4-7:0	R5-7:0
G4-7:0	G5-7:0
B4-7:0	B5-7:0

eDP 2lane 8bit input data mapping

4. LCD Optical Characteristics

4.1 Optical specification

Item	Symbol	Condition	Min.	Typ.	Max.	Unit.	Note
Contrast Ratio	CR	$\Theta=0$	600	800	--		(1)(2)
Response time	Rising	T_R	--	30	35	msec	(1)(3)
	Falling	T_F					
Luminance of/ white	5 Points	ILED = 23mA	340	400	--	cd/m2	
Color Gamut	S(%)		62	67	--	%	
Color Filter Chromaticity	White	W_X	-0.04	0.2902	+0.04		(1)(4) CA31 0
		W_Y		0.3230			
	Red	R_X		0.6406			
		R_Y		0.3520			
	Green	G_X		0.3187			
		G_Y		0.5930			
	Blue	B_X		0.1499			
		B_Y		0.0593			
Viewing angle	Hor.	Θ_L	CR>10	--	85	--	
		Θ_R		--	85	--	
	Ver.	Θ_U		--	85	--	
		Θ_D		--	85	--	
Option View Direction	ALL						

*The data comes from the LCD specification.

Measuring Condition

Measuring surrounding : dark room

Ambient temperature : $25\pm 2^\circ\text{C}$

15min. warm-up time.

Measuring Equipment

FPM520 of Westar Display technologies, INC., which utilized SR-3 for Chromaticity and BM-5A for other optical characteristics.

Note (1): Definition of Viewing Angle :

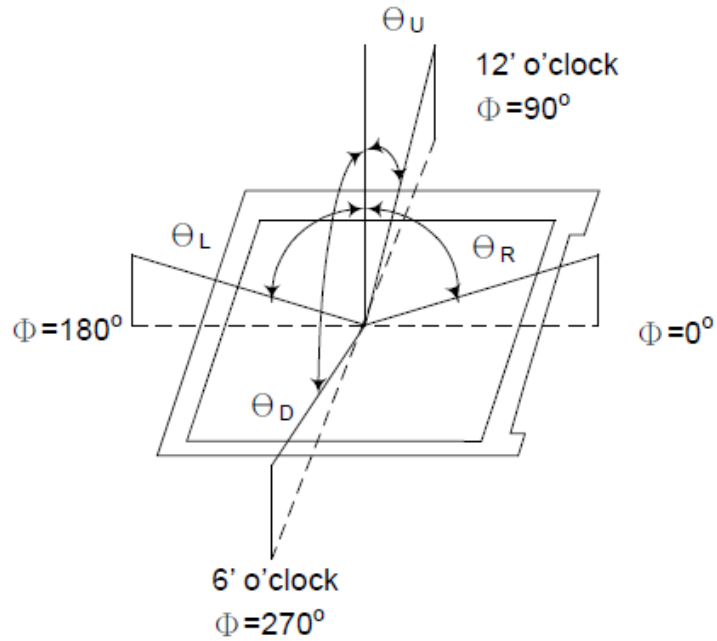

Note (2): Definition of Contrast Ratio(CR) :measured at the center point of panel

$$CR = \frac{\text{Luminance with all pixels white}}{\text{Luminance with all pixels black}}$$

Note (3): Response Time

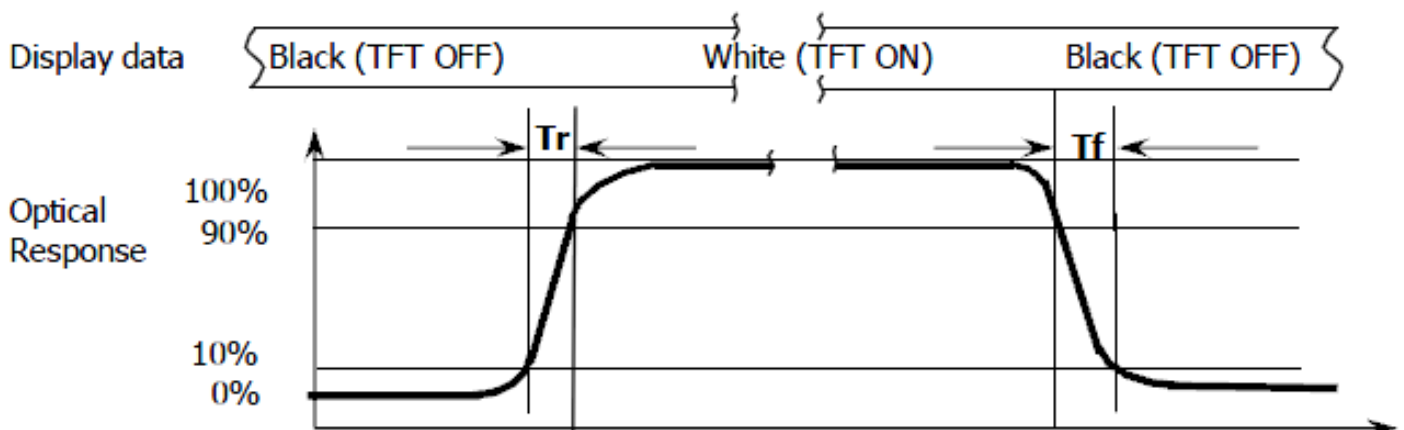

Note (4): Definition of optical measurement setup

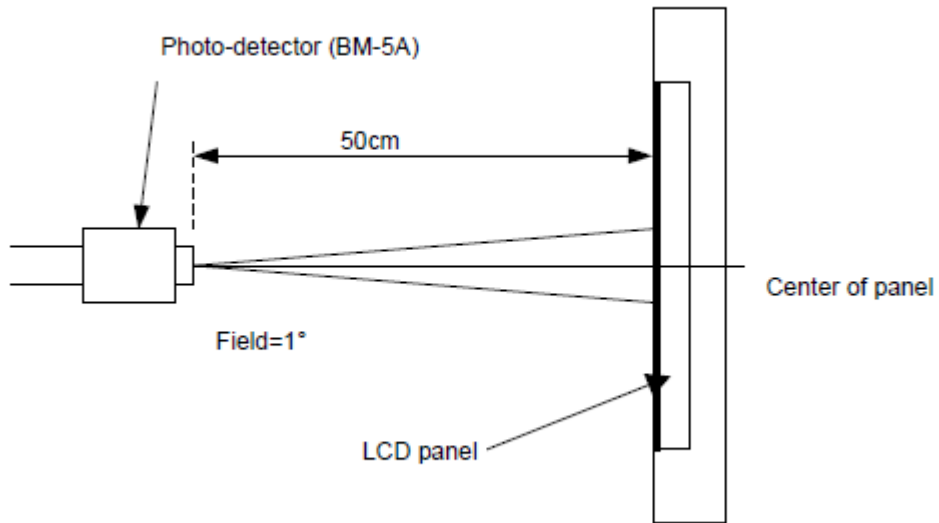

5. Electrical Characteristics

5.1 Absolute Maximum Rating

Characteristics	Symbol	Min.	Max.	Unit	Note
Digital Supply Voltage	LCD_VCC	-0.3	4.0	V	Note1
Operating temperature	T _{OP}	0	+50	°C	
Storage temperature	T _{ST}	-20	+60	°C	

NOTE1: If the absolute maximum rating of even is one of the above parameters is exceeded even momentarily, the quality of the product may be degraded. Absolute maximum ratings, therefore, specify the values exceeding which the product may be physically damaged. Be sure to use the product within the range of the absolute maximum ratings.

5.2 DC Electrical Characteristics

Characteristics	Symbol	Min.	Typ.	Max.	Unit	Note
Power Supply Voltage	LCD_VCC	3.0	3.3	3.6	V	
Permissible Input Ripple Voltage	V _{RF}	--	--	100	mV	
Power Supply Current	I _{DD}	--	212	400	mA	
Differential Input Voltage	V _{ID}	200	--	600	mV	
Power Consumption	P _D	--	0.7	1.4	W	

5.3 LED Backlight Characteristics

The back-light system is edge-lighting type with 54 chips LED

Item	Symbol	Min.	Typ.	Max.	Unit	Note	
Forward Current	I _F	--	180	--	mA		
Forward Voltage	V _F	33.6	34.8	36	V		
LCM Luminance	LV	450	500	--	cd/m ²	IF=180mA	
LED life time	Hr	--	30000	--	Hour	Note1,2	
Uniformity	Avg	80	--	--	%	Note3	

Note1: LED life time (Hr) can be defined as the time in which it continues to operate under the condition:

Ta=25±3 °C, typical IL value indicated in the above table until the brightness becomes less than 50%.

Note 2: The “LED life time” is defined as the module brightness decrease to 50% original brightness at

Ta=25°C and IL=180mA. The LED lifetime could be decreased if operating IL is larger than 180mA.

The constant current driving method is suggested.

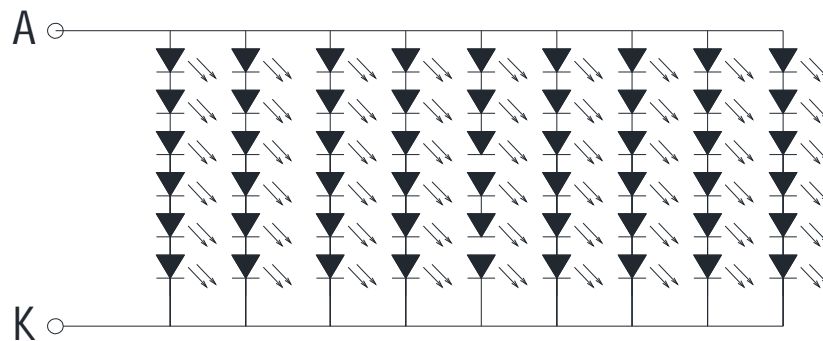

Backlight LED 6*9=54EA Circuit

LED(B/L) CIRCUIT

Note (5) Luminance Uniformity of these 9 points is defined as below:

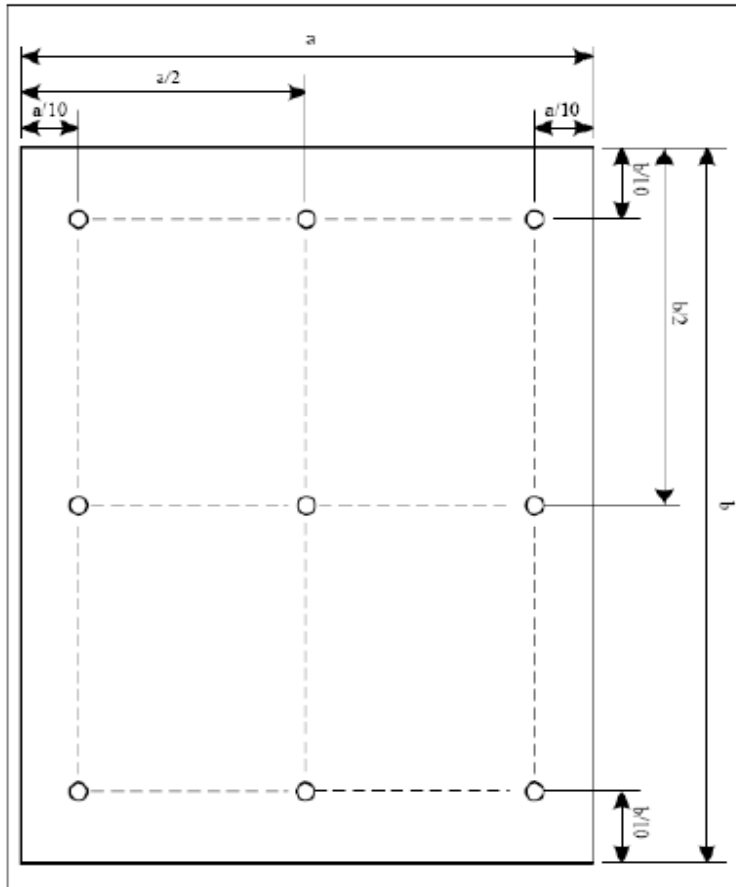

$$\text{Uniformity} = \frac{\text{minimum luminance in 9 points (1-9)}}{\text{maximum luminance in 9 points (1-9)}}$$

$$\text{Luminance} = \frac{\text{Total Luminance of 9 points}}{9}$$

6. Display Port Input Signal Timing Specifications

6.1 Timing Characteristics

The TFT-LCM Module is operated by the DE only.

Item		Symbols	Min	Typ	Max	Unit
Clock	Frequency	1/Tc	136.65	147.84	155	MHz
	High Time	Tch	-	4/7	-	Tc
	Low Time	Tcl	-	3/7	-	Tc
Frame Period		Tv	1095	1120	1130	lines
			-	60	-	Hz
			-	16.7	-	ms
Vertical Display Period		Tvd	-	1080	-	lines
One line Scanning Period		Th	2080	2200	2248	clocks
Horizontal Display Period		Thd	-	1920	-	clocks



Display position of input data(VH)

6.2 eDP Rx Interface Timing Parameter

The specification of the eDP Rx interface timing parameter is shown in Table.

Item	Symbol	Min	Typ	Max	Unit	Remark
Spread spectrum clock	SSC		0.5		%	
Differential peak-to-peak input voltage at package pins	VRX-DIFFp-p	120	0	1200	mV	
Rx input DC common mode voltage	VRX_DC_CM	-	GND	-	V	
Differential termination resistance	RRX-DIFF	80	100	120	Ω	
Single-ended termination resistance	RRX-SE	45	50	60	Ω	
Rx short circuit current limit	IRX_SHORT	-	-	50	mA	
Intra-pair skew at Rx package pins (HBR) RX intra-pair skew tolerance at HBR	LRX_SKEW_INTRA_PAIR	-	-	60	ps	

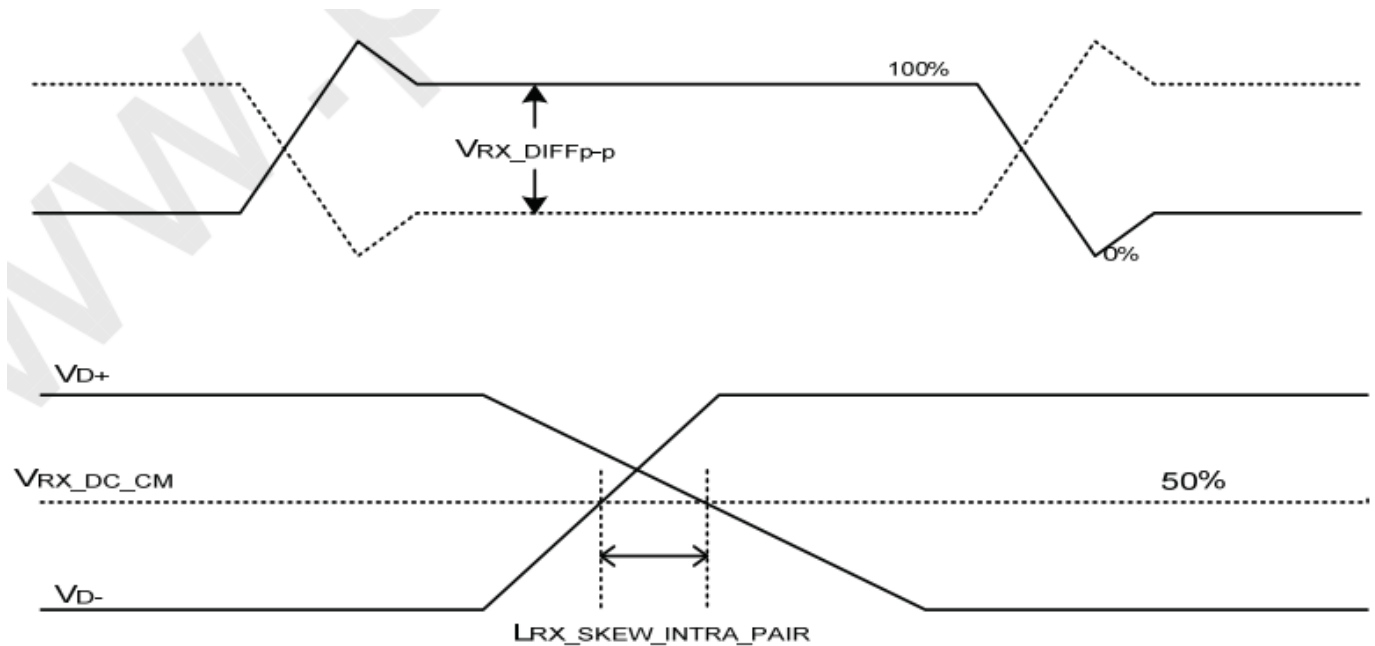

6.4 Power ON/OFF Sequence

To prevent a latch-up or DC operation of the LCD module, the power on/off sequence shall be as shown in below

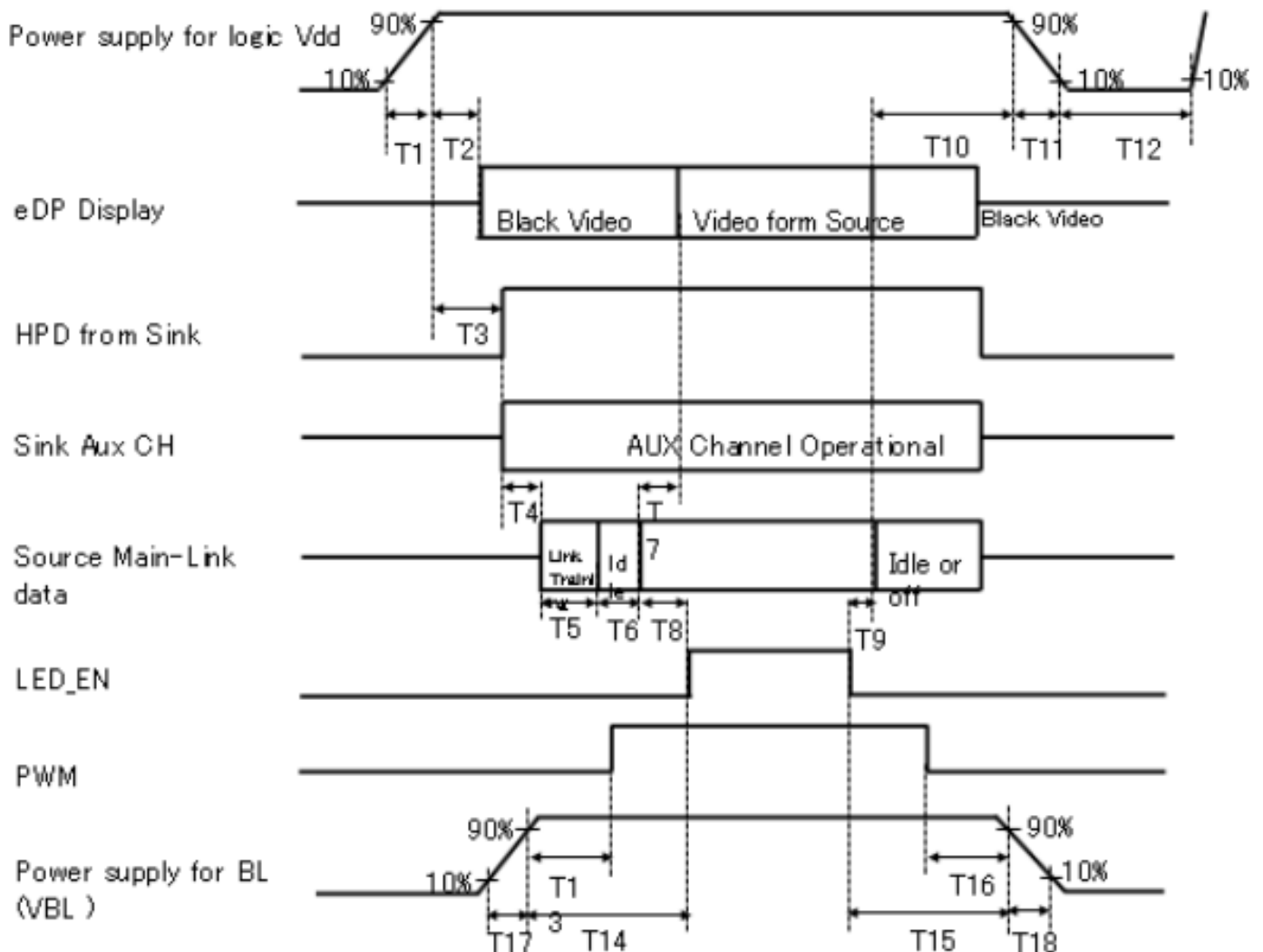

- 0.5ms ≤ T1 ≤ 10 ms
- 0ms ≤ T2 ≤ 200 ms
- 0ms ≤ T3 ≤ 200 ms
- 0ms ≤ T13
- 0ms ≤ T14
- 0ms ≤ T17
- T3+T4+T5+T6+T8 > T2(max)=200ms
- 0ms ≤ T7 ≤ 50ms
- 0ms ≤ T10 ≤ 500 ms
- 0 ms ≤ T11 ≤ 10 ms
- 150ms ≤ T12
- 0ms ≤ T15
- 0ms ≤ T16
- 0ms ≤ T18

Notes:

1. When the power supply VDD is 0V, keep the level of input signals on the low or keep high impedance.
2. Backlight sequence is reference.

6.5 EDID Specifications (TBD)

00	Header	00	0	0	EDID Header
01		FF	255	255	
02		FF	255	255	
03		FF	255	255	
04		FF	255	255	
05		FF	255	255	
06		FF	255	255	
07		00	0	0	
08	ID Manufacturer Name	09	9	BOE	ID = BOE
09		E5	299		
0A	ID Product Code	55	85	2133	ID = 2133
0B		08	8		
0C	32-bit serial No.	00	0	0	
0D		00	0	0	
0E		00	0	0	
0F		00	0	0	
10	Week of manufacture	33	51	51	
11	Year of Manufacture	1C	28	2018	Manufactured in 2018
12	EDID Structure Ver.	01	1	1	EDID Ver 1.0
13	EDID Structure Ver.	04	4	4	EDID Rev. 0.4
14	Video input definition	A5	165	--	Video Signal Interface
15	Max H image size	1F	31	31	31cm (Approx)
16	Max V image size	11	17	17	17cm (Approx)
17	Display Gamma	78	120	2.2	Gamma curve = 2.2
18	Feature support	02	2	--	Feature Support
19	Red/Green low bits	FF	255	--	Red / Green Low Bits
1A	Blue/White low bits	35	53	--	Blue / White Low Bits
1B	Red x high bits	A7	167	0.656	Red(x)= 10100111(0.655)
1C	Red y high bits	56	86	0.339	Red(y)= 01010110(0.339)
1D	Green x high bits	50	80	0.315	Green(x) = 01010000(0.315)
1E	Green y high bits	9F	159	0.624	Green(y) = 10011111(0.624)
1F	Blue x high bits	27	39	0.152	Blue(x) = 00100111(0.152)
20	Blue y high bits	0E	14	0.058	Blue(y) = 00001110(0.058)
21	White x high bits	50	80	0.313	White(x) =01010000(0.313)
22	White y high bits	54	84	0.329	White(y)= 01010100 (0.329)
23	Established timing 1	00	0	--	--
24	Established timing 2	00	0	--	

25	Established timing 3	00	0	--
26	Standard timing #1	01	1	
27		01	1	
28	Standard timing #2	01	1	
29		01	1	
2A	Standard timing #3	01	1	
2B		01	1	
2C	Standard timing #4	01	1	
2D		01	1	
2E	Standard timing #5	01	1	
2F		01	1	
30	Standard timing #6	01	1	
31		01	1	
32	Standard timing #7	01	1	
33		01	1	
34	Standard timing #8	01	1	
35		01	1	
36	Detailed timing/monitor descriptor #1	C0	192	147.8
37		39	57	
38		80	128	1920
39		18	24	280
3A		71	113	--
3B		38	56	1080
3C		28	40	40
3D		40	64	-
3E		30	48	48
3F		20	32	32
40		36	54	3
41		00	0	6
42		35	53	309
43		AE	174	174
44		10	16	--
45		00	0	0
46		00	0	0
47		1A	26	--
48	Detailed timing/monitor descriptor #2	00	0	0.0

49		00	0		
4A		00	0	0	
4B		00	0	0	
4C		00	0	--	
4D		00	0	0	
4E		00	0	0	
4F		00	0	--	
50		00	0	0	
51		00	0	0	
52		00	0	0	
53		00	0	0	
54		00	0	0	
55		00	0	0	
56		00	0	--	
57		00	0	0	
58		00	0	0	
59		00	0	--	
5A	Detailed timing/monitor descriptor #3	00	0		
5B		00	0		
5C		00	0		
5D		FE	254		
5E		00	0		
5F		42	66	B	
60		4F	79	O	
61		45	69	E	
62		20	32		
63		43	67	C	
64		51	81	Q	
65		0A	10		
66		20	32		
67		20	32		
68		20	32		
69		20	32		
6A		20	32		
6B		20	32		
6C	Detailed timing/monitor descriptor #4	00	0		

6D		00	0		
6E		00	0		
6F		FE	254		
70		00	0		
7D		0A	10		
7E	Extension flag	00	0	1	
7F	Checksum	86	134	--	

Notes:

1.EDID custom information not required

7. LCD Module Out-Going Quality Level

7.1 VISUAL & FUNCTION INSPECTION STANDARD

7.1.1 Inspection conditions

Inspection performed under the following conditions is recommended.

Temperature : $25\pm 5^{\circ}\text{C}$

Humidity : $65\%\pm 10\%\text{RH}$

Viewing Angle : Normal viewing Angle.

Illumination: Single fluorescent lamp (300 to 700Lux)

Viewing distance:30-50cm

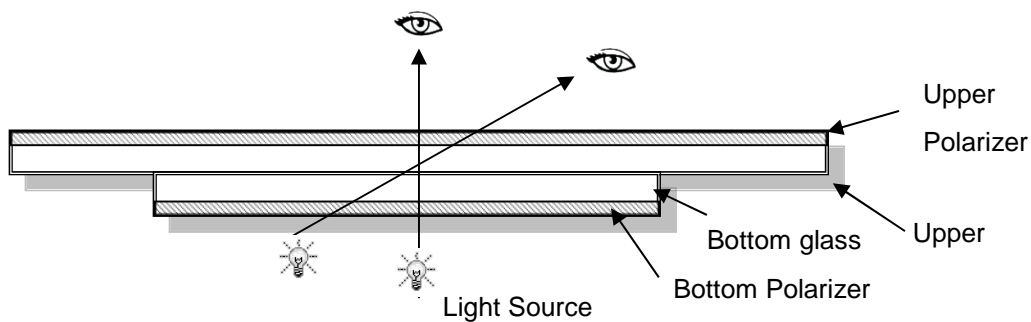

7.1.2 Definition

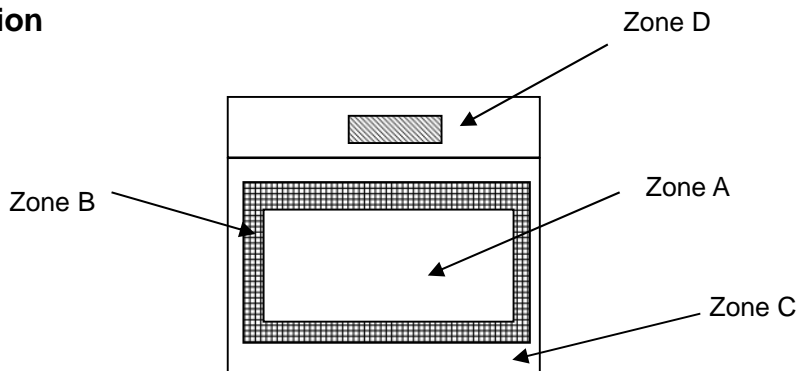

Zone A : Effective Viewing Area(Character or Digit can be seen)

Zone B : Viewing Area except Zone A

Zone C : Outside (Zone A+Zone B) which can not be seen after assembly by customer .)

Zone D : IC Bonding Area

Note:As a general rule ,visual defects in Zone C can be ignored when it doesn't effect product function or appearance after assembly by customer

7.1.3 Sampling Plan

According to GB/T 2828.1-2003 ; , normal inspection, Class II

AQL:

Major defect	Minor defect
0.65	1.5

LCD: Liquid Crystal Display , TP: Touch Panel , LCM: Liquid Crystal Module

No	Items to be inspected	Criteria	Classification of defects
1	Functional defects	1) No display, Open or miss line 2) Display abnormally, Short 3) Backlight no lighting, abnormal lighting.	Major
2	Missing	Missing component	
3	Outline dimension	Overall outline dimension beyond the drawing is not allowed	
4	Color tone	Color unevenness, refer to limited sample	Minor
5	Spot Line defect	Light dot, Dim spot, Polarizer Bubble ; Polarizer accidented spot.	
6	Soldering appearance	Good soldering , Peeling off is not allowed.	
7	LCD/Polarizer	Black/White spot/line, scratch, crack, etc.	

7.1.4 Criteria (Visual)

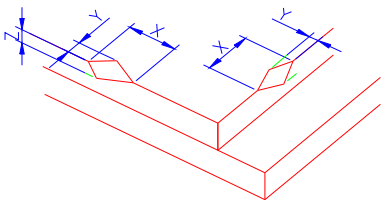
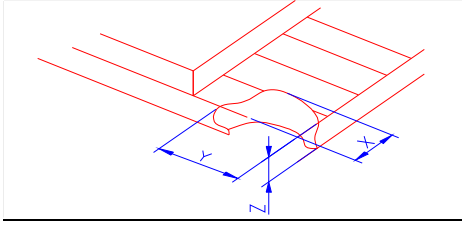
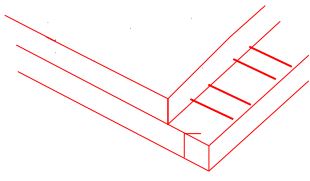
Number	Items	Criteria(mm)						
1.0 LCD Crack/Broken NOTE: X: Length Y: Width Z: Height L: Length of ITO, T: Height of LCD	(1) The edge of LCD broken	 <table border="1" data-bbox="751 611 1452 759"> <thead> <tr> <th>X</th> <th>Y</th> <th>Z</th> </tr> </thead> <tbody> <tr> <td>≤3.0mm</td> <td><Inner border line of the seal</td> <td>≤T</td> </tr> </tbody> </table>	X	Y	Z	≤3.0mm	<Inner border line of the seal	≤T
	X	Y	Z					
	≤3.0mm	<Inner border line of the seal	≤T					
(2)LCD corner broken	 <table border="1" data-bbox="831 1068 1370 1167"> <thead> <tr> <th>X</th> <th>Y</th> <th>Z</th> </tr> </thead> <tbody> <tr> <td>≤3.0mm</td> <td>≤L</td> <td>≤T</td> </tr> </tbody> </table>	X	Y	Z	≤3.0mm	≤L	≤T	
X	Y	Z						
≤3.0mm	≤L	≤T						
(3) LCD crack	 <p style="text-align: center;">Crack Not allowed</p>							

2.0

Spot defect

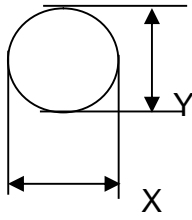

$\Phi=(X+Y)/2$

① light dot (black/white spot , pinhole, stain, etc.)

Zone Size (mm)	Acceptable Qty		
	A	B	C
$\Phi \leq 0.15$	Ignore		
$0.15 < \Phi \leq 0.25$	3(distance ≥ 10 mm)		
$0.25 < \Phi \leq 0.4$	2(distance ≥ 10 mm)		
$\Phi > 0.4$	0		

② Dim spot (light leakage, dent, dark spot, etc)



Zone Size (mm)	Acceptable Qty		
	A	B	C
$\Phi \leq 0.15$	Ignore		
$0.15 < \Phi \leq 0.25$	3(distance ≥ 10 mm)		
$0.25 < \Phi \leq 0.4$	2(distance ≥ 10 mm)		
$\Phi > 0.4$	0		

③ Polarizer accidented spot

Zone Size (mm)	Acceptable Qty		
	A	B	C
$\Phi \leq 0.2$	Ignore		
$0.2 < \Phi \leq 0.5$	2(distance ≥ 10 mm)		
$\Phi > 0.5$	0		

④ Polarizer Bubble

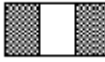
Zone Size (mm)	Acceptable Qty		
	A	B	C
$\Phi \leq 0.2$	Ignore		
$0.2 < \Phi \leq 0.4$	2(distance ≥ 10 mm)		
$\Phi > 0.4$	0		

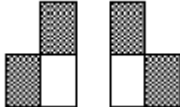
3.0	LCD Pixel defect	<p>Pixel bad points</p> <table border="1"> <thead> <tr> <th data-bbox="534 250 726 302">Item</th> <th data-bbox="726 250 1241 302">Zone A</th> <th data-bbox="1241 250 1492 302">Acceptable Qty</th> </tr> </thead> <tbody> <tr> <td data-bbox="534 302 726 465" rowspan="3">Bright dot</td> <td data-bbox="726 302 1241 362">Random</td> <td data-bbox="1241 302 1492 362">N≤2</td> </tr> <tr> <td data-bbox="726 362 1241 414">2 dots adjacent</td> <td data-bbox="1241 362 1492 414">N≤0</td> </tr> <tr> <td data-bbox="726 414 1241 465">3 dots adjacent</td> <td data-bbox="1241 414 1492 465">N≤0</td> </tr> <tr> <td data-bbox="534 465 726 629" rowspan="3">Dark dot</td> <td data-bbox="726 465 1241 526">Random</td> <td data-bbox="1241 465 1492 526">N≤3</td> </tr> <tr> <td data-bbox="726 526 1241 577">2 dots adjacent</td> <td data-bbox="1241 526 1492 577">N≤0</td> </tr> <tr> <td data-bbox="726 577 1241 629">3 dots adjacent</td> <td data-bbox="1241 577 1492 629">N≤0</td> </tr> <tr> <td data-bbox="534 629 726 943">Distance</td> <td data-bbox="726 629 1241 943"> 1. Minimum Distance Between Bright dots. 2. Minimum Distance Between dark dots 3. Minimum Distance Between dark and bright dot. </td> <td data-bbox="1241 629 1492 943">5mm</td> </tr> <tr> <td colspan="2" data-bbox="534 943 1241 1003">Total bright and dark dot</td> <td data-bbox="1241 943 1492 1003">N≤4</td> </tr> </tbody> </table> <p>Note:</p> <p>A) Bright dot: Dots appear bright and unchanged in size in which LCD panel is displaying under black pattern.</p> <p>B) Dark dot: Dots appear dark and unchanged in size in which LCD panel is displaying under pure red, green, blue picture.</p> <p>C) 2 dot adjacent = 1 pair = 2 dots</p> <p>Picture:</p> <div style="display: flex; justify-content: space-around; align-items: flex-start;"> <div style="text-align: center;">  <p>2 dot adjacent</p> </div> <div style="text-align: center;">  <p>2 dot adjacent</p> </div> <div style="text-align: center;">  <p>2 dot adjacent (vertical)</p> </div> <div style="text-align: center;">  <p>2 dot adjacent (slant)</p> </div> </div>	Item	Zone A	Acceptable Qty	Bright dot	Random	N≤2	2 dots adjacent	N≤0	3 dots adjacent	N≤0	Dark dot	Random	N≤3	2 dots adjacent	N≤0	3 dots adjacent	N≤0	Distance	1. Minimum Distance Between Bright dots. 2. Minimum Distance Between dark dots 3. Minimum Distance Between dark and bright dot.	5mm	Total bright and dark dot		N≤4
Item	Zone A	Acceptable Qty																							
Bright dot	Random	N≤2																							
	2 dots adjacent	N≤0																							
	3 dots adjacent	N≤0																							
Dark dot	Random	N≤3																							
	2 dots adjacent	N≤0																							
	3 dots adjacent	N≤0																							
Distance	1. Minimum Distance Between Bright dots. 2. Minimum Distance Between dark dots 3. Minimum Distance Between dark and bright dot.	5mm																							
Total bright and dark dot		N≤4																							

4.0	Line defect (LCD /Polarizer backlight black/white line, scratch, stain)  W: width, L : length N : Count	<table border="1"> <thead> <tr> <th rowspan="2">Width(mm)</th> <th rowspan="2">Length(m m)</th> <th colspan="3">Acceptable Qty</th> </tr> <tr> <th>A</th> <th>B</th> <th>C</th> </tr> </thead> <tbody> <tr> <td>$\Phi \leq 0.05$</td> <td>Ignore</td> <td colspan="3">Ignore</td> </tr> <tr> <td>$0.05 < W \leq 0.06$</td> <td>$L \leq 5.0$</td> <td colspan="3">$N \leq 3$</td> </tr> <tr> <td>$0.06 < W \leq 0.08$</td> <td>$L \leq 4.0$</td> <td colspan="3">$N \leq 2$</td> </tr> <tr> <td>$W > 0.08$</td> <td colspan="4">Define as spot defect</td> </tr> </tbody> </table>	Width(mm)	Length(m m)	Acceptable Qty			A	B	C	$\Phi \leq 0.05$	Ignore	Ignore			$0.05 < W \leq 0.06$	$L \leq 5.0$	$N \leq 3$			$0.06 < W \leq 0.08$	$L \leq 4.0$	$N \leq 2$			$W > 0.08$	Define as spot defect			
		Width(mm)			Length(m m)	Acceptable Qty																								
			A	B		C																								
		$\Phi \leq 0.05$	Ignore	Ignore																										
		$0.05 < W \leq 0.06$	$L \leq 5.0$	$N \leq 3$																										
$0.06 < W \leq 0.08$	$L \leq 4.0$	$N \leq 2$																												
$W > 0.08$	Define as spot defect																													
5.0	Electronic Components SMT.	Not allow missing parts, solderless connection, cold solder joint, mismatch, The positive and negative polarity opposite																												
6.0	Display color & Brightness.	1. Color: Measuring the color coordinates, The measurement standard according to the datasheet or samples. 2. Brightness: Measuring the brightness of White screen, The measurement standard according to the datasheet or Samples.																												
7.0	LCD Mura/Waving/ Hot spot	Not visible through 5% ND filter in 50% gray or judge by limit sample if necessary.																												

Criteria (functional items)

Number	Items	Criteria (mm)
1	No display	Not allowed
2	Missing segment	Not allowed
3	Short	Not allowed
4	Backlight no lighting	Not allowed
5	CTP no function	Not allowed

8. Reliability Test Result

Item	Condition	Inspection after test
High Temperature Operating	50°C,96H	Inspection after 2~4hours storage at room temperature, the sample shall be free from defects: 1.Air bubble in the LCD; 2.Non-display; 3.Missing segments/line; 4.Glass crack; 5.Current IDD is twice higher than initial value.
Low Temperature Operating	0°C, 96HR	
High Temperature Storage	60°C, 96HR	
Low Temperature Storage	-20°C, 96HR	
High Temperature & High Humidity Operating	60°C, 80% RH ,96hours.	
Thermal Shock (Non-operation)	-20°C,30 min ↔ +60°C,30 min, Change time:5min 20CYC.	
ESD test	C=150pF, R=330,5points/panel Air:±15KV, 5times; Contact:±8KV, 5 times; (Environment: 15°C~35°C, 30%~60%).	
Vibration (Non-operation)	Frequency range:10~500Hz, Stroke:1.5mm Sweep:10Hz~500Hz~10Hz 1 hours for each direction of X.Y.Z. (1 hours for total) (Package condition).	
Box Drop Test	1 Corner 3 Edges 6 faces,80cm(MEDIUM BOX)	

Remark:

- 1.The test samples should be applied to only one test item.
- 2.Sample size for each test item is 5~10pcs.
- 3.For Damp Proof Test, Pure water(Resistance > 10MΩ) should be used.
- 4.In case of malfunction defect caused by ESD damage, if it would be recovered to normal state after resetting, it would be judged as a good part.
- 5.Failure Judgment Criterion: Basic Specification, Electrical Characteristic, Mechanical Characteristic, Optical Characteristic.

9. Cautions and Handling Precautions

9.1 Handling and Operating the Module

(1) When the module is assembled, it should be attached to the system firmly.

Do not warp or twist the module during assembly work.

(2) Protect the module from physical shock or any force. In addition to damage, this may cause improper operation or damage to the module and back-light unit.

(3) Note that polarizer is very fragile and could be easily damaged. Do not press or scratch the surface.

(4) Do not allow drops of water or chemicals to remain on the display surface.

If you have the droplets for a long time, staining and discoloration may occur.

(5) If the surface of the polarizer is dirty, clean it using some absorbent cotton or soft cloth.

(6) The desirable cleaners are water, IPA (Isopropyl Alcohol) or Hexane.

Do not use ketene type materials (ex. Acetone), Ethyl alcohol, Toluene, Ethyl acid or Methyl chloride. It might permanent damage to the polarizer due to chemical reaction.

(7) If the liquid crystal material leaks from the panel, it should be kept away from the eyes or mouth. In case of contact with hands, legs, or clothes, it must be washed away thoroughly with soap.

(8) Protect the module from static; it may cause damage to the CMOS ICs.

(9) Use finger-stalls with soft gloves in order to keep display clean during the incoming inspection and assembly process.

(10) Do not disassemble the module.

(11) Protection film for polarizer on the module shall be slowly peeled off just before use so that the electrostatic charge can be minimized.

(12) Pins of I/F connector shall not be touched directly with bare hands.

(13) Do not connect, disconnect the module in the "Power ON" condition.

9.2 Storage and Transportation.

(1) Do not leave the panel in high temperature, and high humidity for a long time.

It is highly recommended to store the module with temperature from 0 to 35 °C and relative humidity of less than 70%

(2) Do not store the TFT-LCD module in direct sunlight.

(3) The module shall be stored in a dark place. When storing the modules for a long time, be sure to adopt effective measures for protecting the modules from strong ultraviolet radiation, sunlight, or fluorescent light.

(4) It is recommended that the modules should be stored under a condition where no condensation is allowed. Formation of dewdrops may cause an abnormal operation or a failure of the module.

In particular, the greatest possible care should be taken to prevent any module from being operated where condensation has occurred inside.

(5) This panel has its circuitry FPC on the bottom side and should be handled carefully in order not to be stressed.