

Display Elektronik GmbH

DATA SHEET

TFT MODULE

DEM 19201080E VM-PW-N

15,6“ TFT

Product Specification

Version: 0

13.12.2024

Contents

1. Block Diagram	5
2. Outline dimension	5
3. Input terminal Pin Assignment	6
4. LCD Optical Characteristics	9
4.1 Optical specification	9
5. Electrical Characteristics	12
5.1 Absolute Maximum Rating	12
5.2 DC Electrical Characteristics	12
5.3 LED Backlight Characteristics	13
6. Electrical Specifications	12
6.1 LVDS Characteristics	12
6.2 Temperature Specifications	12
6.3 LVDS Interface	13
6.4 Interface Timing	12
6.5 Power On/Off Sequence	20
7. LCD Module Out-Going Quality Level.	21
7.1 VISUAL & FUNCTION INSPECTION STANDARD	21
7.1.1 Inspection conditions	21
7.1.2 Definition Zone D	21
7.1.3 Sampling Plan	22
7.1.4 Criteria (Visual)	23
8. Reliability Test Result	27
9. Cautions and Handling Precautions	28
9.1 Handling and Operating the Module	28
9.2 Storage and Transportation.	28

*** Description**

This is a color active matrix TFT (Thin Film Transistor) LCD (liquid crystal display) that uses amorphous silicon TFT as a switching device. This model is composed of a Transmissive type TFT-LCD Panel, driver circuit, back-light unit. The resolution of a 15.6' TFT-LCD contains 1920X1080 pixels, and can display up to 16.7M colors.

*** Features**

General Information Items	Specification	Unit	Note
	Main Panel		
Display area(AA)	344.16(H)*193.59(V) (15.6inch)	mm	
Driver element	TFT active matrix	-	
Display colors	16.7M	colors	
Number of pixels	1920(RGB)*1080	dots	
Pixel arrangement	RGB vertical stripe	-	
Pixel pitch	0.05975(H)*0.17925(V)	mm	
Viewing angle	Supper wide angle	o'clock	
LCM Interface	Dual 8 BIT LVDS	-	
Display mode	Normally Black	-	
Operating temperature	0~+50	°C	
Storage temperature	-20~+60	°C	

*** Mechanical Information**

Item		Min.	Typ.	Max.	Unit	Note
Module size	Horizontal(H)	-	351.86	-	mm	
	Vertical(V)	-	206.33	-	mm	
	Depth(D)	-	6.5	-	mm	
Weight		-	TBD	-	g	

1. Block Diagram

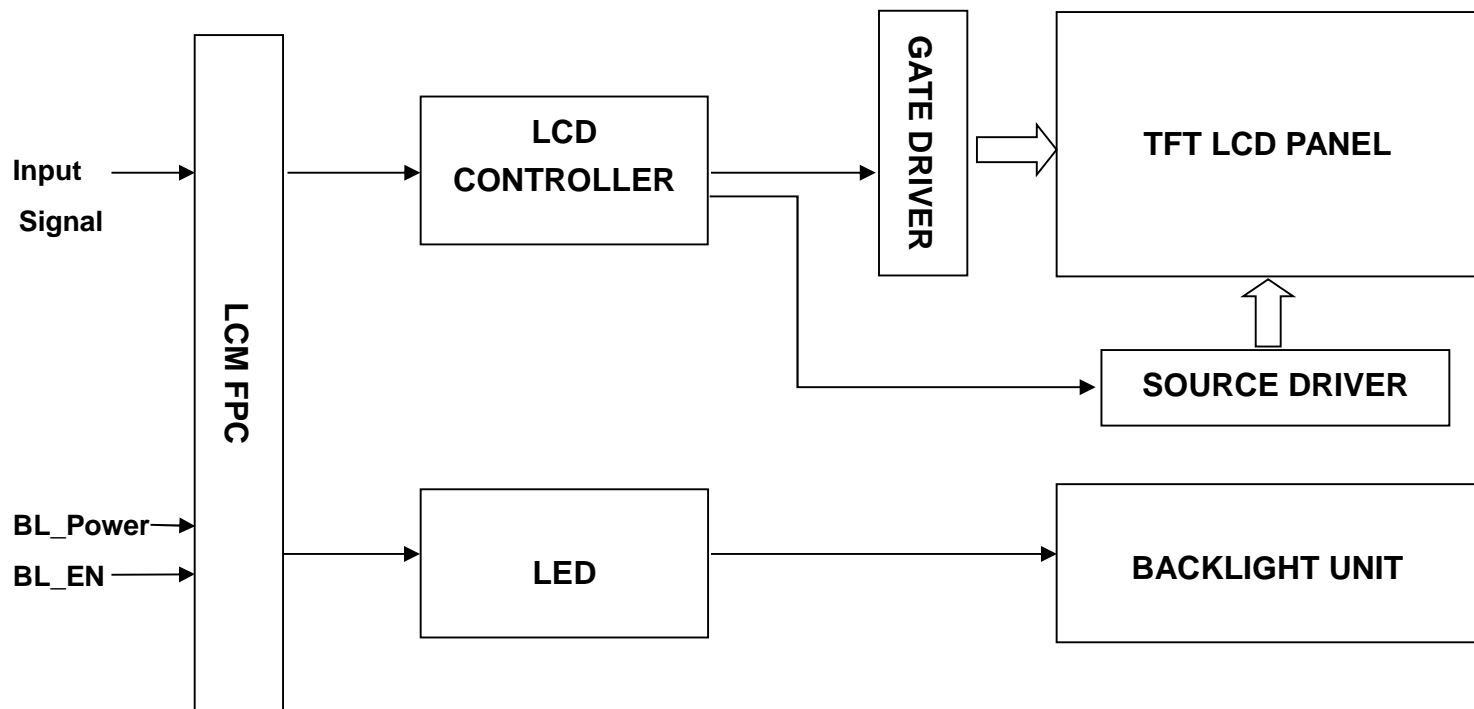

2. Outline dimension

PN	NAME
1	R0001
2	R0001
3	R0001
4	R0001
5	R0001
6	R0001
7	COND
8	R0001
9	R0001
10	000
11	R0001
12	R0001
13	000
14	R0001
15	R0001
16	R0001
17	R0001
18	R0001
19	R0001
20	000
21	R0001
22	R0001
23	000
24	R0001
25	R0001
26	COND
27	000
28	000
29	000
30	000
31	000
32	000
33	000
34	000
35	000
36	000
37	000
38	000
39	000
40	000

BACK VIEW

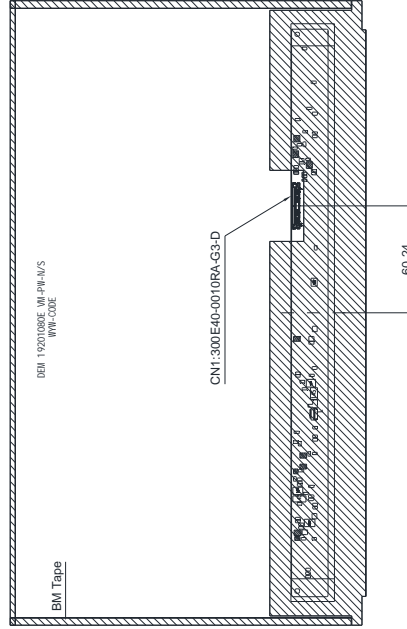

SIDE VIEW



TOP VIEW

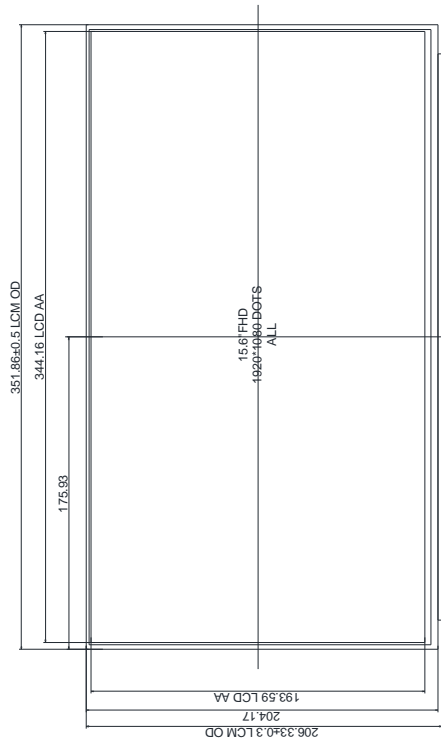

- NOTES:
1. DISPLAY TYPE: 15.6" TFT-LCD, 16.2M COLORS.
 2. DISPLAY MODE: IPS NORMALLY BLACK.
 3. VIEWING DIRECTION: FREE
 4. TFT DRIVER IC: NA
 5. TFT Interface: Dual 8 BIT LVDS
 6. VCC: 12V
 7. OPERATING TEMP: 0°C TO 50°C
STORAGE TEMP: -20°C TO 60°C
 8. RoHS and COMPLIANT

3. Input terminal Pin Assignment**The electronics interface connector is 300E40-0010RA-G3-D(CT)**

NO.	SYMBOL	DISCRIPTION	I/O
1	RxO0-	Negative LVDS differential data input(Odd data)	I
2	RxO0+	Positive LVDS differential data input(Odd data)	I
3	RxO1-	Negative LVDS differential data input(Odd data)	I
4	RxO1+	Positive LVDS differential data input(Odd data)	I
5	RxO2-	Negative LVDS differential data input(Odd data)	I
6	RxO2+	Positive LVDS differential data input(Odd data)	I
7	GND	Ground	P
8	RxOCLK-	Negative LVDS differential clock input(Odd data)	I
9	RxOCLK+	Positive LVDS differential clock input(Odd data)	I
10	GND	Ground	P
11	RxO3-	Negative LVDS differential data input(Odd data)	I
12	RxO3+	Positive LVDS differential data input(Odd data)	I
13	GND	Ground	P
14	RxE0-	Negative LVDS differential data input(Even data)	I
15	RxE0+	Positive LVDS differential data input(Even data)	I
16	RxE1-	Negative LVDS differential data input(Even data)	P
17	RxE1+	Positive LVDS differential data input(Even data)	I
18	RxE2-	Negative LVDS differential data input(Even data)	I
19	RxE2+	Positive LVDS differential data input(Even data)	I
20	GND	Ground	P
21	RxECLK-	Negative LVDS differential clock input(Even data)	I
22	RxECLK+	Positive LVDS differential clock input(Even data)	I
23	GND	Ground	P
24	RxE3-	Negative LVDS differential data input(Even data)	I
25	RxE3+	Positive LVDS differential data input(Even data)	I
26	GND	Ground	P

27	LCD_VCC	LCD VCC(12V)	P
28	LCD_VCC	LCD VCC(12V)	P
29	BIST	LCD self-test(Normal mode:NC or pull L;BIST mode:pull H)	P
30	BL_ENABLE	Backlight on/off (3.3V input)	P
31	BL_PWM_DIM	System PWM	P
32	BL_POWER	LED Power Supply Input Voltage(12V)	P
33	BL_POWER	LED Power Supply Input Voltage(12V)	P
34	BL_POWER	LED Power Supply Input Voltage(12V)	P
35	BL_POWER	LED Power Supply Input Voltage(12V)	P
36	GND	Ground	P
37	GND	Ground	P
38	GND	Ground	P
39	ID1	Reserved PIN,Default"H",Recommend NC	I
40	ID2	Reserved PIN,Default"L",Recommend NC	I

4. LCD Optical Characteristics

4.1 Optical specification

Item	Symbol	Condition	Min.	Typ.	Max.	Unit.	Note
Contrast Ratio	CR	$\Theta=0$	150	2500	--		(1)(2)
Response time	Rising	T_R	0	30	35	msec	(1)(3)
	Falling	T_F					
LCM Luminance			270	310		cd/m2	
Color Gamut		S(%)	--	66	--	%	
Color Filter Chromacity	White	W_X	-0.04	0.3044	+0.04		(1)(4) CA31 0
		W_Y		0.3313			
	Red	R_X		0.6400			
		R_Y		0.3475			
	Green	G_X		0.3124			
		G_Y		0.5893			
	Blue	B_X		0.1489			
		B_Y		0.0717			
Viewing angle	Hor.	Θ_L	80	89	--		
		Θ_R	80	89	--		
	Ver.	Θ_U	80	89	--		
		Θ_D	80	89	--		
Option View Direction		SUPPER WIDE ANGLIE					

*The data comes from the LCD specification.

Measuring Condition

Measuring surrounding : dark room

Ambient temperature : 25±2°C

15min. warm-up time.

Measuring Equipment

FPM520 of Westar Display technologies, INC., which utilized SR-3 for Chromaticity and BM-5A for other optical characteristics.

Note (1): Definition of Viewing Angle :

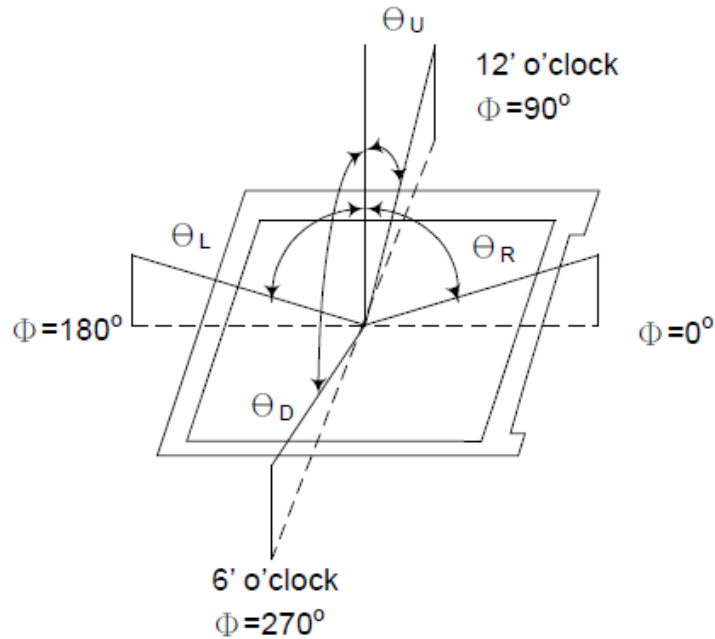

Note (2): Definition of Contrast Ratio(CR) :measured at the center point of panel

$$CR = \frac{\text{Luminance with all pixels white}}{\text{Luminance with all pixels black}}$$

Note (3): Response Time

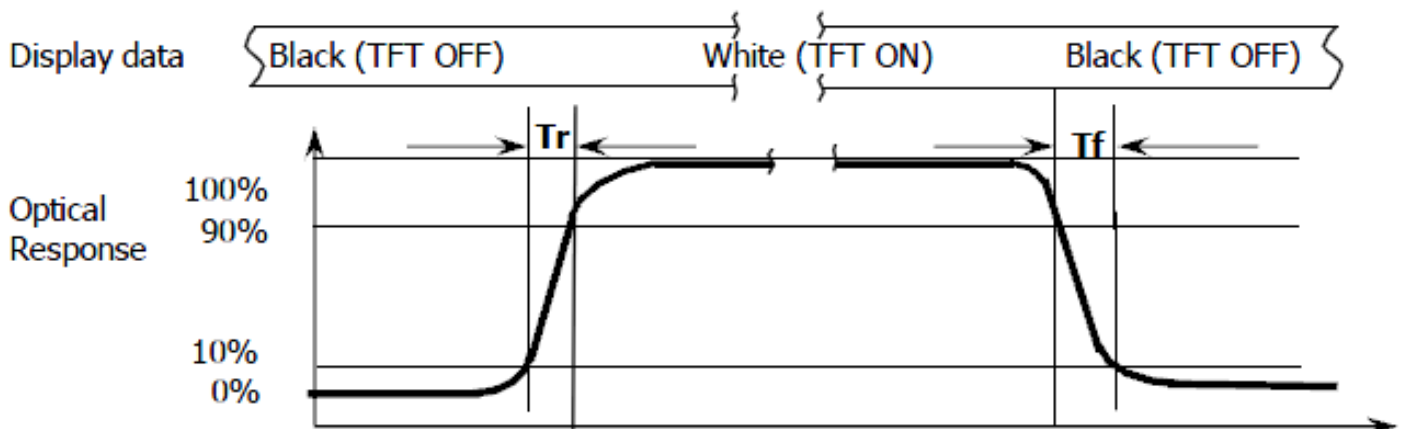

Note (4): Definition of optical measurement setup

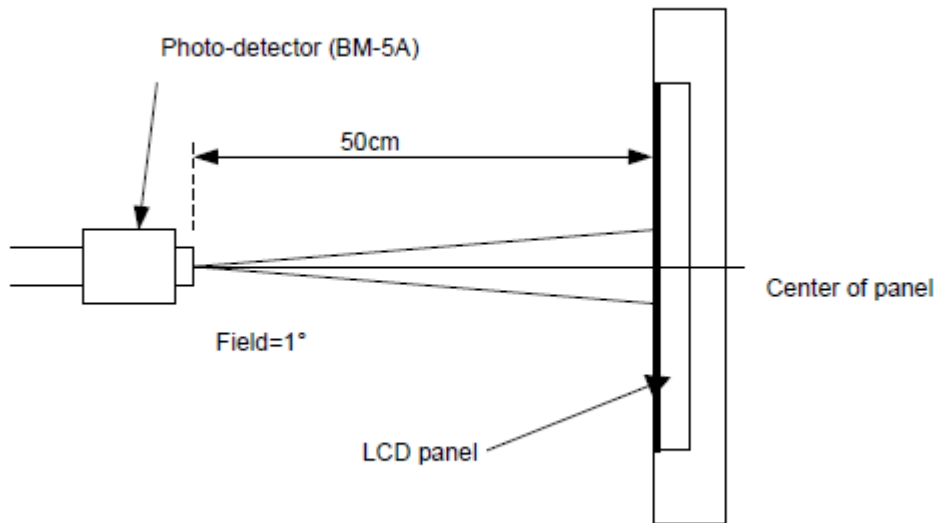

5. Electrical Characteristics

5.1 Absolute Maximum Rating

Characteristics	Symbol	Min.	Max.	Unit	Note
Digital Supply Voltage	LCD_VCC	-0.3	13.2	V	Note1
Operating temperature	T _{OP}	0	+50	°C	
Storage temperature	T _{ST}	-20	+60	°C	

NOTE1: If the absolute maximum rating of even is one of the above parameters is exceeded even momentarily, the quality of the product may be degraded. Absolute maximum ratings, therefore, specify the values exceeding which the product may be physically damaged. Be sure to use the product within the range of the absolute maximum ratings.

5.2 DC Electrical Characteristics

Characteristics	Symbol	Min.	Typ.	Max.	Unit	Note
Digital Supply Voltage	LCD_VCC	10.8	12	13.2	V	
Normal mode Current	I _{DD}	--	100	--	mA	
Level input voltage	V _{IH}	0.7LCD_VCC		LCD_VCC	V	
	V _{IL}	GND		0.3 LCD_VCC	V	
Level output voltage	V _{OH}	LCDVCC-0.4		--	V	
	V _{OL}	GND		GND+0.4	V	

5.3 LED Backlight Characteristics

Note (1) Luminance Uniformity of these 9 points is defined as below:

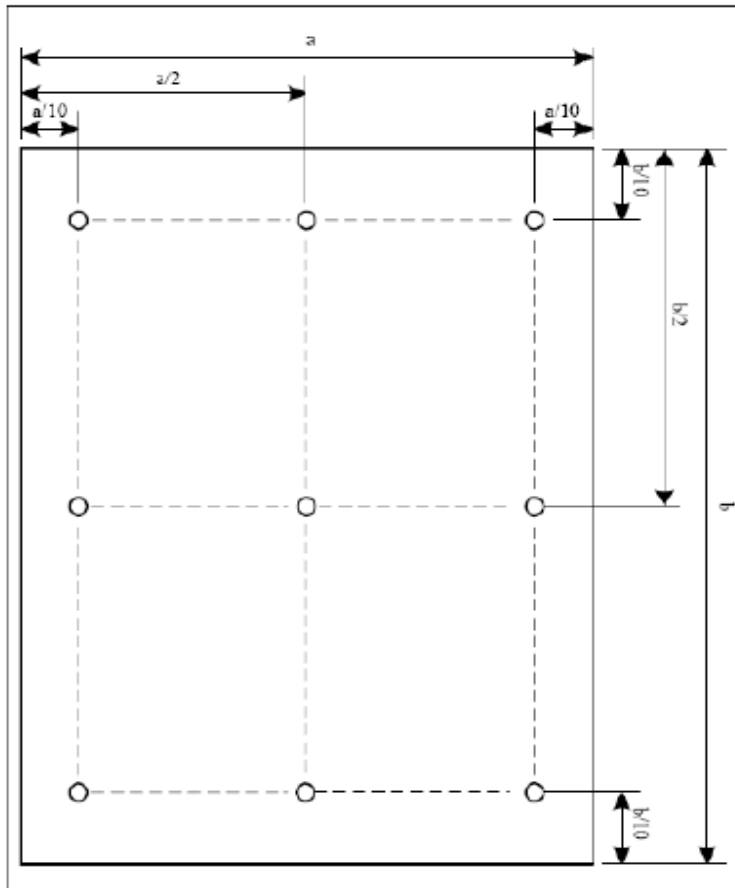

$$\text{Uniformity} = \frac{\text{minimum luminance in 9 points (1-9)}}{\text{maximum luminance in 9 points (1-9)}}$$

$$\text{Luminance} = \frac{\text{Total Luminance of 9 points}}{9}$$

BACK-Light&lcm Interface Connection

The back-light system is edge-lighting type with 54 chips White LED (6strings and 9PCS LED in one string).

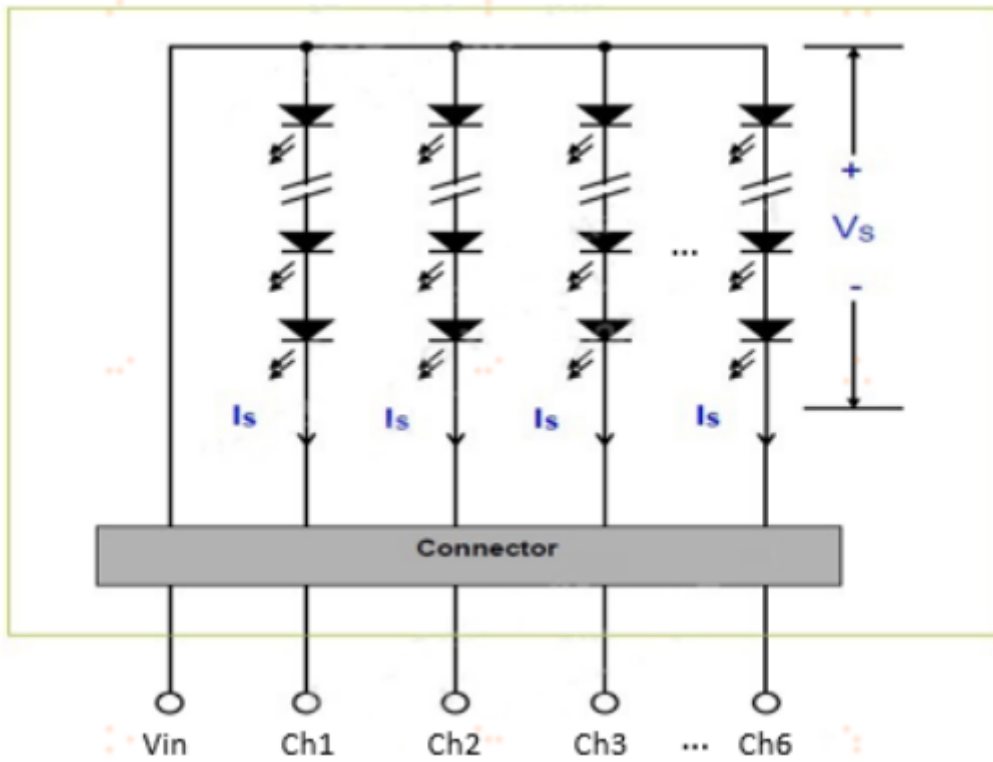

Pin#	Symbol	Description	Remark
1	Vout	LED anode connection	
2	Vout	LED anode connection	
3	Vout	LED anode connection	
4	NC	NC	
5	LED	LED Cathode connection	
6	LED	LED Cathode connection	
7	LED	LED Cathode connection	
8	LED	LED Cathode connection	
9	LED	LED Cathode connection	
10	LED	LED Cathode connection	

6. Electrical Specifications

6.1 LVDS Characteristics

Parameter	Symbol	Value			Unit	Note	
		Min.	Typ.	Max.			
LVDS Interface	Differential Input High Threshold Voltage	V _{TH}	+100	-	-	mV	(1)
	Differential Input Low Threshold Voltage	V _{TL}	-	-	-100	mV	
	Common Input Voltage	V _{CM}	1.0	1.2	1.4	V	
	Differential Input Voltage	V _{ID}	100	-	600	mV	
	Terminating Resistor	R _T	87.5	100	112.5	ohm	
CMOS Interface	Input High Threshold Voltage	V _{IH}	2.7	-	3.3	V	
	Input Low Threshold Voltage	V _{IL}	0	-	0.7	V	

Note:

- (1) The product should be always operated within above ranges.
- (2) The LVDS input signal has been defined as follows:

Single end Signals



Differential Signal

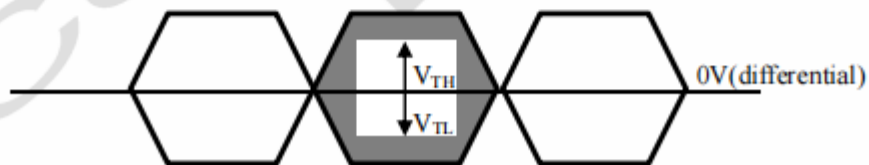

6.2 Temperature Specifications

Parameter	Symbol	Spec			Unit	Note
		Min.	Typ.	Max.		
Source driver	T _{DRIVER}	-	-	115	°C	(1)
PMIC	T _{PMIC}	-	-	100	°C	(1)
TCON	T _{TCON}	-	-	105	°C	(1)

Note:

(1) Any point on the IC surface must be less than Max. specification under any condition ,If the surface temperature is out of the specification, thermal solutions should be applied to avoid to be damaged.

6.3 LVDS Interface

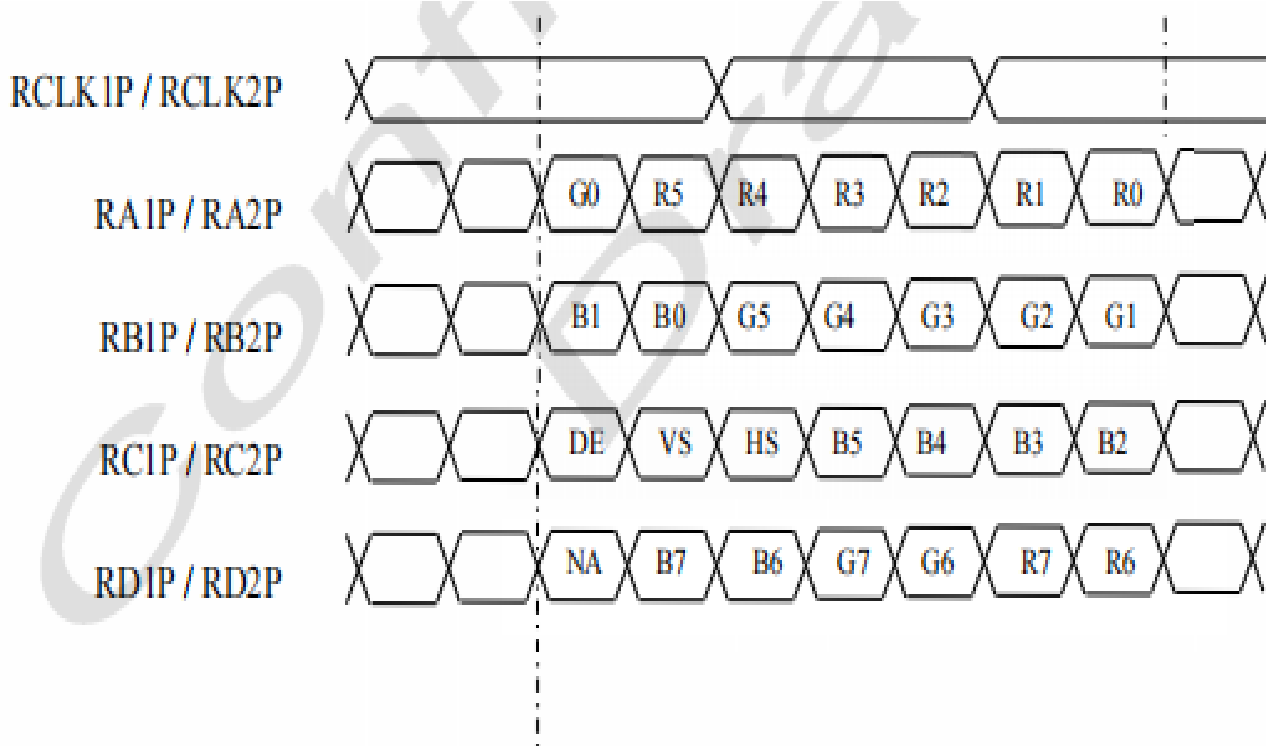

6.4 Interface Timing

Signal	Item	Symbol	Min.	Typ.	Max.	Unit	Note
LVDS Receiver Clock	Frequency	Felkin (=1/TClk)	64	74.25	96	MHz	(1) (2)
	Input cycle to cycle jitter	Trcl	—	—	200	ps	(3)
	Spread spectrum modulation range	Felkin_mod	Felkin-2%	—	Felkin+2%	MHz	(4)
	Spread spectrum modulation frequency	FSSM	60	—	200	KHz	
LVDS Receiver Data	Receiver Skew Margin	TRSM	-400	—	400	ps	(5)
Vertical Active Display Term	Frame Rate	F	48	60	75	Hz	
	Total	TV	1092	1125	1380	TH	TV = TVD + TVB
	Display	TVD	1080				
	Blank	TVB	12	45	300	TH	
Horizontal Active Display Term	Total	TH	1046	1100	1174	TCLK	TH = THD + THB
	Display	THD	960				
	Blank	THB	86	140	214	TCLK	

Note:

(1) The TFT LCD open cell is operated in DE only mode, H sync and V sync input signal have no effect on normal operation.

(2) Please make sure the range of pixel clock follows the following equations:

$$Felkin(max) \geq Fmax \times Tv \times Th \quad Fmin \times Tv \times Th \geq Felkin(min)$$

Main frequency Max is 96Mhz without spread spectrum

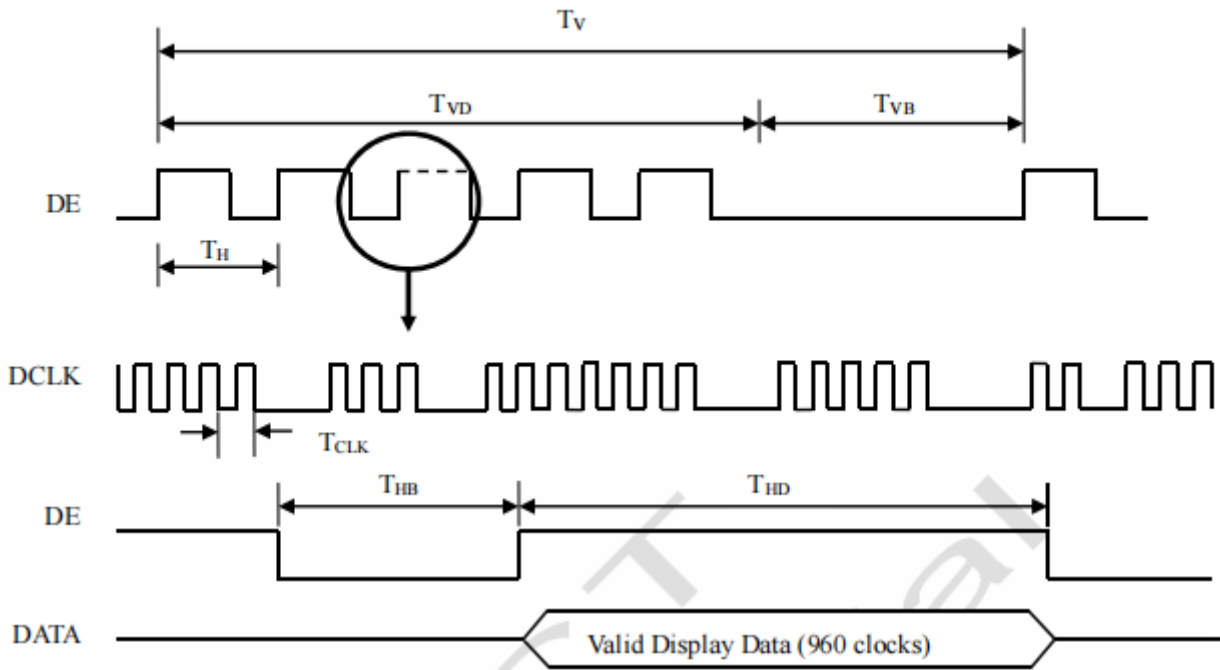
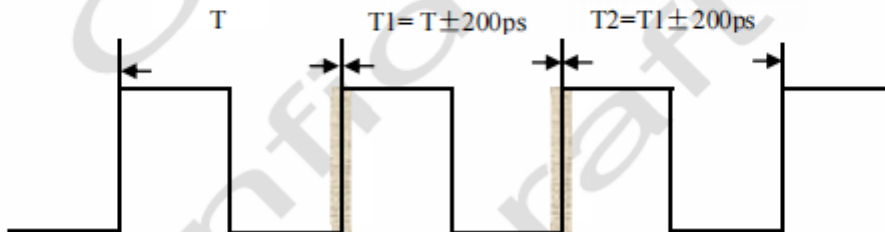

Fig. 5.1 Interface signal timing diagram

(3)The input clock cycle-to-cycle is defined as below figures.



(4) The SSCG (Spread Spectrum Clock Generator) is defined as the following figure.

The LVDS SSCG's suggestion is off by default, SOC board must test all validation if SOC board open the LVDS SSCG.

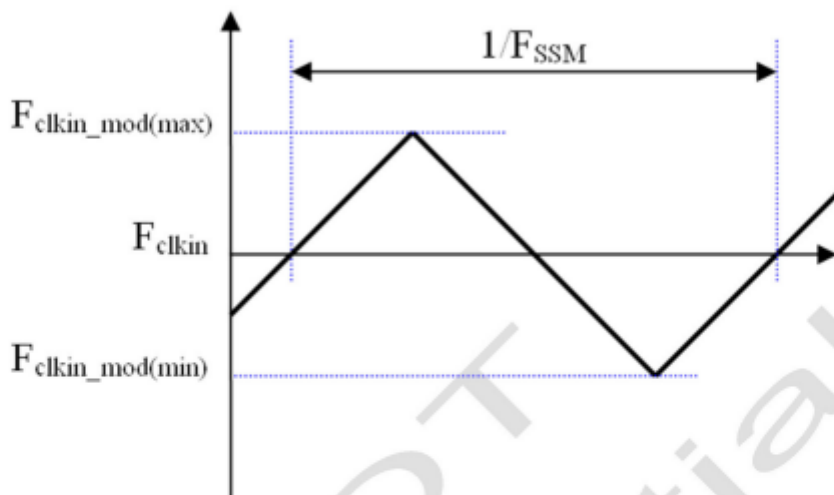
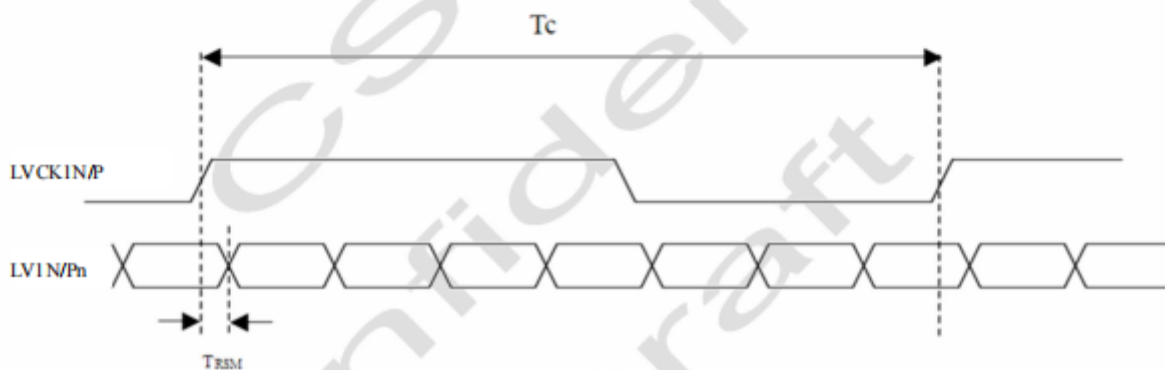

Fig. 5.3 SSCG

(5) The LVDS timing diagram and setup/hold time is defined and showed as the following figure.



6.5 Power On/Off Sequence

To prevent a latch-up or DC operation of the Open cell, the power on/off sequence should be as the diagram below.

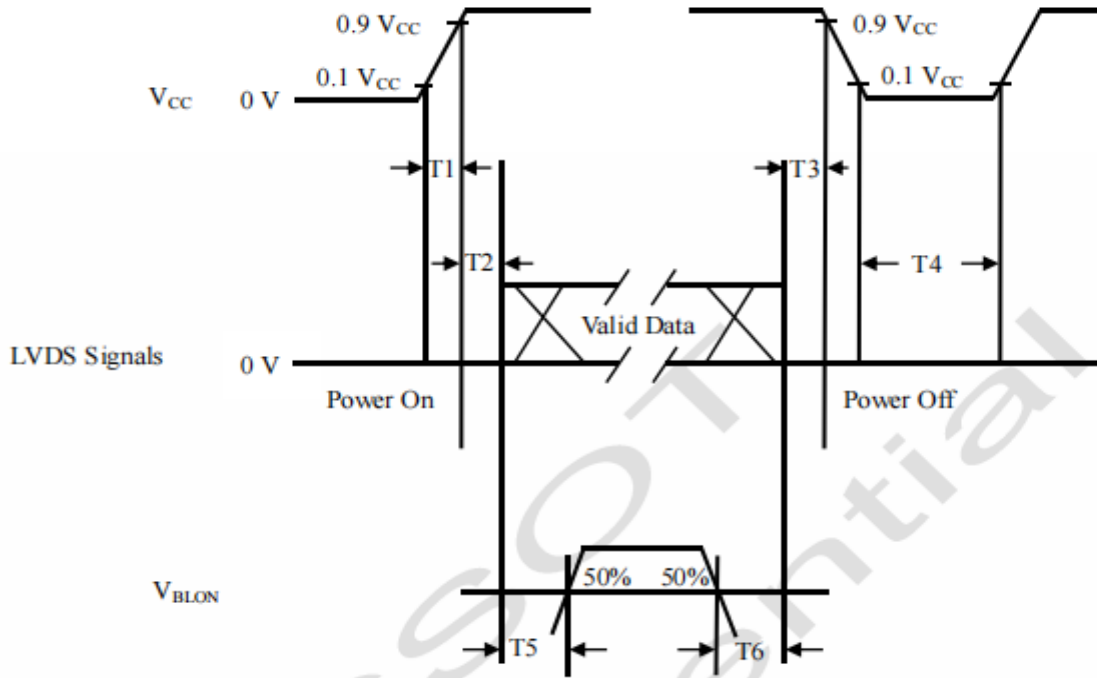

Fig.5.5 Power on/off sequence

Parameter	Values			Unit
	Min.	Typ.	Max.	
T1	0.5	-	10.0	ms
T2	0.0	-	50	ms
T3	0.0	-	50	ms
T4	1000.0	-	-	ms
T5	500.0	-	-	ms
T6	100.0	-	-	ms

Attention:

- (1) The supply voltage of the external system for the open cell input should follow the definition of VCC.
- (2) When the customer's backlight turns on before the LCD operation or the LCD turns off before the backlight turns off, the display may momentarily become abnormal screen.
- (3) In case that VCC is in off level, please keep the level of input signals on the low or high impedance. If T2 < 0, that may cause electrical overstress.
- (4) T4 should be measured after the module has been fully discharged between power off and on period.
- (5) Interface signal shall not be kept at high impedance when the power is on.

7. LCD Module Out-Going Quality Level

7.1 VISUAL & FUNCTION INSPECTION STANDARD

7.1.1 Inspection conditions

Inspection performed under the following conditions is recommended.

Temperature : $25\pm 5^{\circ}\text{C}$

Humidity : $65\%\pm 10\%RH$

Viewing Angle : Normal viewing Angle.

Illumination: Single fluorescent lamp (300 to 700Lux)

Viewing distance:30-50cm

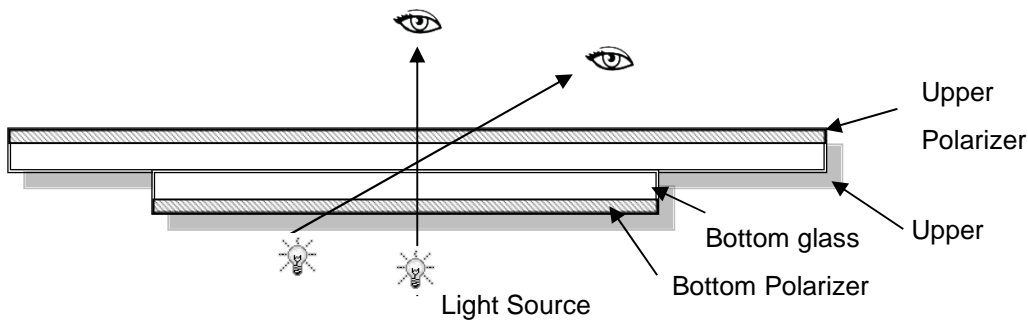

7.1.2 Definition

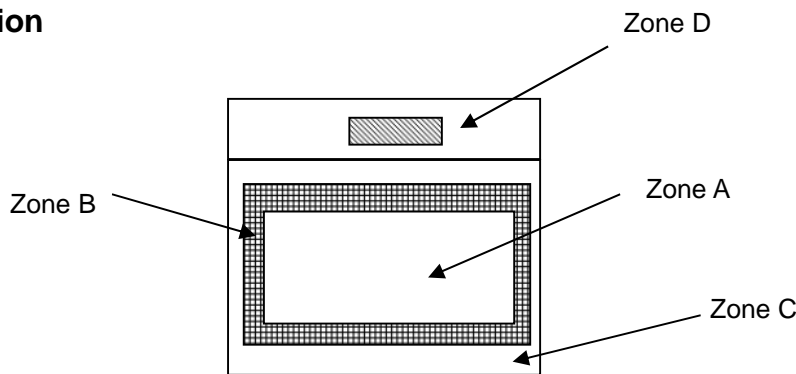

Zone A : Effective Viewing Area(Character or Digit can be seen)

Zone B : Viewing Area except Zone A

Zone C : Outside (Zone A+Zone B) which can not be seen after assembly by customer .)

Zone D : IC Bonding Area

Note:As a general rule ,visual defects in Zone C can be ignored when it doesn't effect product function or appearance after assembly by customer

7.1.3 Sampling Plan

According to GB/T 2828.1-2003 ; , normal inspection, Class II

AQL:

Major defect	Minor defect
0.65	1.5

LCD: Liquid Crystal Display , TP: Touch Panel , LCM: Liquid Crystal Module

No	Items to be inspected	Criteria	Classification of defects
1	Functional defects	1) No display, Open or miss line 2) Display abnormally, Short 3) Backlight no lighting, abnormal lighting.	Major
2	Missing	Missing component	
3	Outline dimension	Overall outline dimension beyond the drawing is not allowed	
4	Color tone	Color unevenness, refer to limited sample	Minor
5	Spot Line defect	Light dot, Dim spot,Polarizer Bubble ; Polarizer accidented spot.	
6	Soldering appearance	Good soldering , Peeling off is not allowed.	
7	LCD/Polarizer	Black/White spot/line, scratch, crack, etc.	

7.1.4 Criteria (Visual)

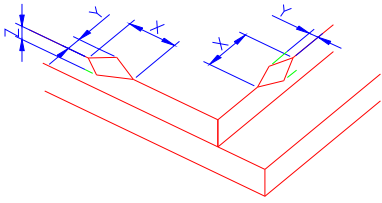
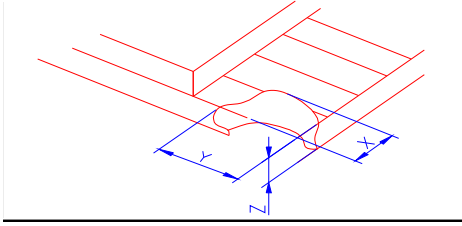
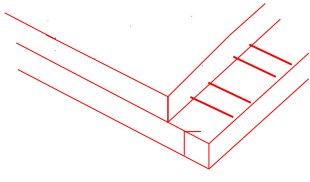
Number	Items	Criteria(mm)						
1.0 LCD Crack/Broken NOTE: X: Length Y: Width Z: Height L: Length of ITO, T: Height of LCD	(1) The edge of LCD broken	 <table border="1" data-bbox="751 651 1450 801"> <thead> <tr> <th>X</th> <th>Y</th> <th>Z</th> </tr> </thead> <tbody> <tr> <td>≤3.0mm</td> <td><Inner border line of the seal</td> <td>≤T</td> </tr> </tbody> </table>	X	Y	Z	≤3.0mm	<Inner border line of the seal	≤T
X	Y	Z						
≤3.0mm	<Inner border line of the seal	≤T						
	(2)LCD corner broken	 <table border="1" data-bbox="831 1111 1370 1211"> <thead> <tr> <th>X</th> <th>Y</th> <th>Z</th> </tr> </thead> <tbody> <tr> <td>≤3.0mm</td> <td>≤L</td> <td>≤T</td> </tr> </tbody> </table>	X	Y	Z	≤3.0mm	≤L	≤T
X	Y	Z						
≤3.0mm	≤L	≤T						
	(3) LCD crack	 <p style="text-align: center;">Crack Not allowed</p>						

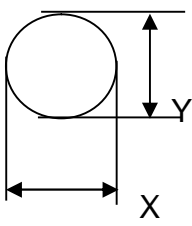
2.0	Spot defect	<p>⊙ light dot (black/white spot , pinhole, stain, etc.)</p> <table border="1" style="width: 100%; border-collapse: collapse;"> <thead> <tr> <th rowspan="2" style="text-align: center;">Zone Size (mm)</th> <th colspan="3" style="text-align: center;">Acceptable Qty</th> </tr> <tr> <th style="text-align: center;">A</th> <th style="text-align: center;">B</th> <th style="text-align: center;">C</th> </tr> </thead> <tbody> <tr> <td style="text-align: center;">$\Phi \leq 0.15$</td> <td colspan="3" style="text-align: center;">Ignore</td> </tr> <tr> <td style="text-align: center;">$0.15 < \Phi \leq 0.25$</td> <td colspan="3" style="text-align: center;">3(distance ≥ 10mm)</td> </tr> <tr> <td style="text-align: center;">$0.25 < \Phi \leq 0.4$</td> <td colspan="3" style="text-align: center;">2(distance ≥ 10mm)</td> </tr> <tr> <td style="text-align: center;">$\Phi > 0.4$</td> <td colspan="3" style="text-align: center;">0</td> </tr> </tbody> </table> <p>⊙ Dim spot (light leakage, dent, dark spot, etc)</p> <table border="1" style="width: 100%; border-collapse: collapse;"> <thead> <tr> <th rowspan="2" style="text-align: center;">Zone Size (mm)</th> <th colspan="3" style="text-align: center;">Acceptable Qty</th> </tr> <tr> <th style="text-align: center;">A</th> <th style="text-align: center;">B</th> <th style="text-align: center;">C</th> </tr> </thead> <tbody> <tr> <td style="text-align: center;">$\Phi \leq 0.15$</td> <td colspan="3" style="text-align: center;">Ignore</td> </tr> <tr> <td style="text-align: center;">$0.15 < \Phi \leq 0.25$</td> <td colspan="3" style="text-align: center;">3(distance ≥ 10mm)</td> </tr> <tr> <td style="text-align: center;">$0.25 < \Phi \leq 0.4$</td> <td colspan="3" style="text-align: center;">2(distance ≥ 10mm)</td> </tr> <tr> <td style="text-align: center;">$\Phi > 0.4$</td> <td colspan="3" style="text-align: center;">0</td> </tr> </tbody> </table> <p>③ Polarizer accidented spot</p> <table border="1" style="width: 100%; border-collapse: collapse;"> <thead> <tr> <th rowspan="2" style="text-align: center;">Zone Size (mm)</th> <th colspan="3" style="text-align: center;">Acceptable Qty</th> </tr> <tr> <th style="text-align: center;">A</th> <th style="text-align: center;">B</th> <th style="text-align: center;">C</th> </tr> </thead> <tbody> <tr> <td style="text-align: center;">$\Phi \leq 0.2$</td> <td colspan="3" style="text-align: center;">Ignore</td> </tr> <tr> <td style="text-align: center;">$0.2 < \Phi \leq 0.5$</td> <td colspan="3" style="text-align: center;">2(distance ≥ 10mm)</td> </tr> <tr> <td style="text-align: center;">$\Phi > 0.5$</td> <td colspan="3" style="text-align: center;">0</td> </tr> </tbody> </table> <p>④ Polarizer Bubble</p> <table border="1" style="width: 100%; border-collapse: collapse;"> <thead> <tr> <th rowspan="2" style="text-align: center;">Zone Size (mm)</th> <th colspan="3" style="text-align: center;">Acceptable Qty</th> </tr> <tr> <th style="text-align: center;">A</th> <th style="text-align: center;">B</th> <th style="text-align: center;">C</th> </tr> </thead> <tbody> <tr> <td style="text-align: center;">$\Phi \leq 0.2$</td> <td colspan="3" style="text-align: center;">Ignore</td> </tr> <tr> <td style="text-align: center;">$0.2 < \Phi \leq 0.4$</td> <td colspan="3" style="text-align: center;">2(distance ≥ 10mm)</td> </tr> <tr> <td style="text-align: center;">$\Phi > 0.4$</td> <td colspan="3" style="text-align: center;">0</td> </tr> </tbody> </table>	Zone Size (mm)	Acceptable Qty			A	B	C	$\Phi \leq 0.15$	Ignore			$0.15 < \Phi \leq 0.25$	3(distance ≥ 10 mm)			$0.25 < \Phi \leq 0.4$	2(distance ≥ 10 mm)			$\Phi > 0.4$	0			Zone Size (mm)	Acceptable Qty			A	B	C	$\Phi \leq 0.15$	Ignore			$0.15 < \Phi \leq 0.25$	3(distance ≥ 10 mm)			$0.25 < \Phi \leq 0.4$	2(distance ≥ 10 mm)			$\Phi > 0.4$	0			Zone Size (mm)	Acceptable Qty			A	B	C	$\Phi \leq 0.2$	Ignore			$0.2 < \Phi \leq 0.5$	2(distance ≥ 10 mm)			$\Phi > 0.5$	0			Zone Size (mm)	Acceptable Qty			A	B	C	$\Phi \leq 0.2$	Ignore			$0.2 < \Phi \leq 0.4$	2(distance ≥ 10 mm)			$\Phi > 0.4$	0		
	Zone Size (mm)			Acceptable Qty																																																																																		
A		B	C																																																																																			
$\Phi \leq 0.15$	Ignore																																																																																					
$0.15 < \Phi \leq 0.25$	3(distance ≥ 10 mm)																																																																																					
$0.25 < \Phi \leq 0.4$	2(distance ≥ 10 mm)																																																																																					
$\Phi > 0.4$	0																																																																																					
Zone Size (mm)	Acceptable Qty																																																																																					
	A	B	C																																																																																			
$\Phi \leq 0.15$	Ignore																																																																																					
$0.15 < \Phi \leq 0.25$	3(distance ≥ 10 mm)																																																																																					
$0.25 < \Phi \leq 0.4$	2(distance ≥ 10 mm)																																																																																					
$\Phi > 0.4$	0																																																																																					
Zone Size (mm)	Acceptable Qty																																																																																					
	A	B	C																																																																																			
$\Phi \leq 0.2$	Ignore																																																																																					
$0.2 < \Phi \leq 0.5$	2(distance ≥ 10 mm)																																																																																					
$\Phi > 0.5$	0																																																																																					
Zone Size (mm)	Acceptable Qty																																																																																					
	A	B	C																																																																																			
$\Phi \leq 0.2$	Ignore																																																																																					
$0.2 < \Phi \leq 0.4$	2(distance ≥ 10 mm)																																																																																					
$\Phi > 0.4$	0																																																																																					
	 <p style="text-align: center;">$\Phi = (X+Y)/2$</p>																																																																																					

3.0	LCD Pixel defect	Pixel bad points		
		Item	Zone A	Acceptable Qty
		Bright dot	Random	N≤2
			2 dots adjacent	N≤0
			3 dots adjacent	N≤0
		Dark dot	Random	N≤3
			2 dots adjacent	N≤0
3 dots adjacent	N≤0			
Distance	1. Minimum Distance Between Bright dots. 2. Minimum Distance Between dark dots 3. Minimum Distance Between dark and bright dot.	5mm		
Total bright and dark dot		N≤4		

Note:

A) Bright dot: Dots appear bright and unchanged in size in which LCD panel is displaying under black pattern.

B) Dark dot: Dots appear dark and unchanged in size in which LCD panel is displaying under pure red, green, blue picture.

C) 2 dot adjacent = 1 pair = 2 dots

Picture:



2 dot adjacent

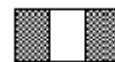

2 dot adjacent



2 dot adjacent (vertical)



2 dot adjacent (slant)

4.0	Line defect (LCD /Polarizer backlight black/white line, scratch, stain)  W: width, L : length N : Count	<table border="1"> <thead> <tr> <th rowspan="2">Width(mm)</th> <th rowspan="2">Length(m)</th> <th colspan="3">Acceptable Qty</th> </tr> <tr> <th>A</th> <th>B</th> <th>C</th> </tr> </thead> <tbody> <tr> <td>$\Phi \leq 0.05$</td> <td>Ignore</td> <td colspan="3">Ignore</td> </tr> <tr> <td>$0.05 < W \leq 0.06$</td> <td>$L \leq 5.0$</td> <td colspan="3">N\leq3</td> </tr> <tr> <td>$0.06 < W \leq 0.08$</td> <td>$L \leq 4.0$</td> <td colspan="3">N\leq2</td> </tr> <tr> <td>$W > 0.08$</td> <td colspan="4">Define as spot defect</td> </tr> </tbody> </table>	Width(mm)	Length(m)	Acceptable Qty			A	B	C	$\Phi \leq 0.05$	Ignore	Ignore			$0.05 < W \leq 0.06$	$L \leq 5.0$	N \leq 3			$0.06 < W \leq 0.08$	$L \leq 4.0$	N \leq 2			$W > 0.08$	Define as spot defect			
		Width(mm)			Length(m)	Acceptable Qty																								
			A	B		C																								
		$\Phi \leq 0.05$	Ignore	Ignore																										
		$0.05 < W \leq 0.06$	$L \leq 5.0$	N \leq 3																										
$0.06 < W \leq 0.08$	$L \leq 4.0$	N \leq 2																												
$W > 0.08$	Define as spot defect																													
5.0	Electronic Components SMT.	Not allow missing parts, solderless connection, cold solder joint, mismatch, The positive and negative polarity opposite																												
6.0	Display color & Brightness.	1. Color: Measuring the color coordinates, The measurement standard according to the datasheet or samples. 2. Brightness: Measuring the brightness of White screen, The measurement standard according to the datasheet or Samples.																												
7.0	LCD Mura/Waving/ Hot spot	Not visible through 5% ND filter in 50% gray or judge by limit sample if necessary.																												

Criteria (functional items)

Number	Items	Criteria (mm)
1	No display	Not allowed
2	Missing segment	Not allowed
3	Short	Not allowed
4	Backlight no lighting	Not allowed
5	CTP no function	Not allowed

8. Reliability Test Result

Item	Condition	Inspection after test
High Temperature Operating	50°C,96H	Inspection after 2~4hours storage at room temperature, the sample shall be free from defects: 1.Air bubble in the LCD; 2.Non-display; 3.Missing segments/line; 4.Glass crack; 5.Current IDD is twice higher than initial value.
Low Temperature Operating	0°C, 96HR	
High Temperature Storage	60°C, 96HR	
Low Temperature Storage	-20°C, 96HR	
High Temperature & High Humidity Operating	60°C, 80% RH ,96hours.	
Thermal Shock (Non-operation)	-20°C,30 min ↔ +60°C,30 min, Change time:5min 20CYC.	
ESD test	C=150pF, R=330,5points/panel Air:±15KV, 5times; Contact:±8KV, 5 times; (Environment: 15°C~35°C, 30%~60%).	
Vibration (Non-operation)	Frequency range:10~500Hz, Stroke:1.5mm Sweep:10Hz~500Hz~10Hz 1 hours for each direction of X.Y.Z. (1 hours for total) (Package condition).	
Box Drop Test	1 Corner 3 Edges 6 faces,80cm(MEDIUM BOX)	

Remark:

- 1.The test samples should be applied to only one test item.
- 2.Sample size for each test item is 5~10pcs.
- 3.For Damp Proof Test, Pure water(Resistance > 10MΩ) should be used.
- 4.In case of malfunction defect caused by ESD damage, if it would be recovered to normal state after resetting, it would be judged as a good part.
- 5.Failure Judgment Criterion: Basic Specification, Electrical Characteristic, Mechanical Characteristic, Optical Characteristic.

9. Cautions and Handling Precautions

9.1 Handling and Operating the Module

(1) When the module is assembled, it should be attached to the system firmly.

Do not warp or twist the module during assembly work.

(2) Protect the module from physical shock or any force. In addition to damage, this may cause improper operation or damage to the module and back-light unit.

(3) Note that polarizer is very fragile and could be easily damaged. Do not press or scratch the surface.

(4) Do not allow drops of water or chemicals to remain on the display surface.

If you have the droplets for a long time, staining and discoloration may occur.

(5) If the surface of the polarizer is dirty, clean it using some absorbent cotton or soft cloth.

(6) The desirable cleaners are water, IPA (Isopropyl Alcohol) or Hexane.

Do not use ketene type materials (ex. Acetone), Ethyl alcohol, Toluene, Ethyl acid or Methyl chloride. It might permanent damage to the polarizer due to chemical reaction.

(7) If the liquid crystal material leaks from the panel, it should be kept away from the eyes or mouth. In case of contact with hands, legs, or clothes, it must be washed away thoroughly with soap.

(8) Protect the module from static; it may cause damage to the CMOS ICs.

(9) Use finger-stalls with soft gloves in order to keep display clean during the incoming inspection and assembly process.

(10) Do not disassemble the module.

(11) Protection film for polarizer on the module shall be slowly peeled off just before use so that the electrostatic charge can be minimized.

(12) Pins of I/F connector shall not be touched directly with bare hands.

(13) Do not connect, disconnect the module in the "Power ON" condition.

9.2 Storage and Transportation.

(1) Do not leave the panel in high temperature, and high humidity for a long time.

It is highly recommended to store the module with temperature from 0 to 35 °C and relative humidity of less than 70%

(2) Do not store the TFT-LCD module in direct sunlight.

(3) The module shall be stored in a dark place. When storing the modules for a long time, be sure to adopt effective measures for protecting the modules from strong ultraviolet radiation, sunlight, or fluorescent light.

(4) It is recommended that the modules should be stored under a condition where no condensation is allowed. Formation of dewdrops may cause an abnormal operation or a failure of the module.

In particular, the greatest possible care should be taken to prevent any module from being operated where condensation has occurred inside.

(5) This panel has its circuitry FPC on the bottom side and should be handled carefully in order not to be stressed.