

DISPLAY Elektronik GmbH

DATA SHEET

LCD MODULE

DEM 16226 SBH-PW-N

Product Specification

Version: 0

30.05.2024

GENERAL SPECIFICATION

MODULE NO. :

DEM 16226 SBH-PW-N

CUSTOMER P/N

VERSION NO.	CHANGE DESCRIPTION	DATE
0	ORIGINAL VERSION	30.05.2024

PREPARED BY: CC

DATE: 30.05.2024

APPROVED BY: WH

DATE: 30.05.2024

CONTENTS

1.FUNCTIONS & FEATURES2

2. MECHANICAL SPECIFICATIONS.....2

3. BLOCK DIAGRAM3

4. EXTERNAL DIMENSIONS4

5.PIN DESCRIPTION5

6.PCB DRAWING AND DESCRIPTION5

7. BACKLIGHT ELECTRICAL/OPTICAL SPECIFCATIONS6

8. MAXIMUM ABSOLUTE POWER RATINGS7

9. ELECTRICAL CHARACTERISTICS7

10. CONTOL AND DISPLAY COMMAND9

11. STANDARD CHARACTER PATTERN(ST7066U-0A).....10

12. ELECTRO-OPTICAL DEFINITION11

13. QUALITY DESCRIPTION.....13

14. RELIABILITY TEST14

15. LCD MODULES HANDLING PRECAUTIONS14

16. OTHERS15

1.FUNCTIONS & FEATURES

I DEM 16226 Series LCD Type :

MODULE	LCD TYPE	REMARK
DEM 16226 SBH-PW-N	STN Blue Transmissive Negative Mode	

- I Display Format :16x2 Characters
- I Viewing Direction : 6 O'clock
- I Driving Scheme : 1/16 Duty Cycle, 1/5 Bias
- I Power Supply Voltage :5V
- I V_{LCD} : 4.5V
- I Operation Temperature : -20°C to +70°C
- I Storage Temperature : -30°C to +80°C
- I Backlight Color : LED White
- I LCD Controller : ST7066U

2. MECHANICAL SPECIFICATIONS

- I Module Size : 65.50 x 36.70 x 12.50mm
- I Viewing Area : 51.80 x 14.80mm
- I Character Pitch : 2.95 x 5.17mm
- I Character Size :2.45 x4.67mm
- I Dot Pitch : 0.50 x 0.59mm
- I Dot Size : 0.45 x 0.54 mm

3. BLOCK DIAGRAM

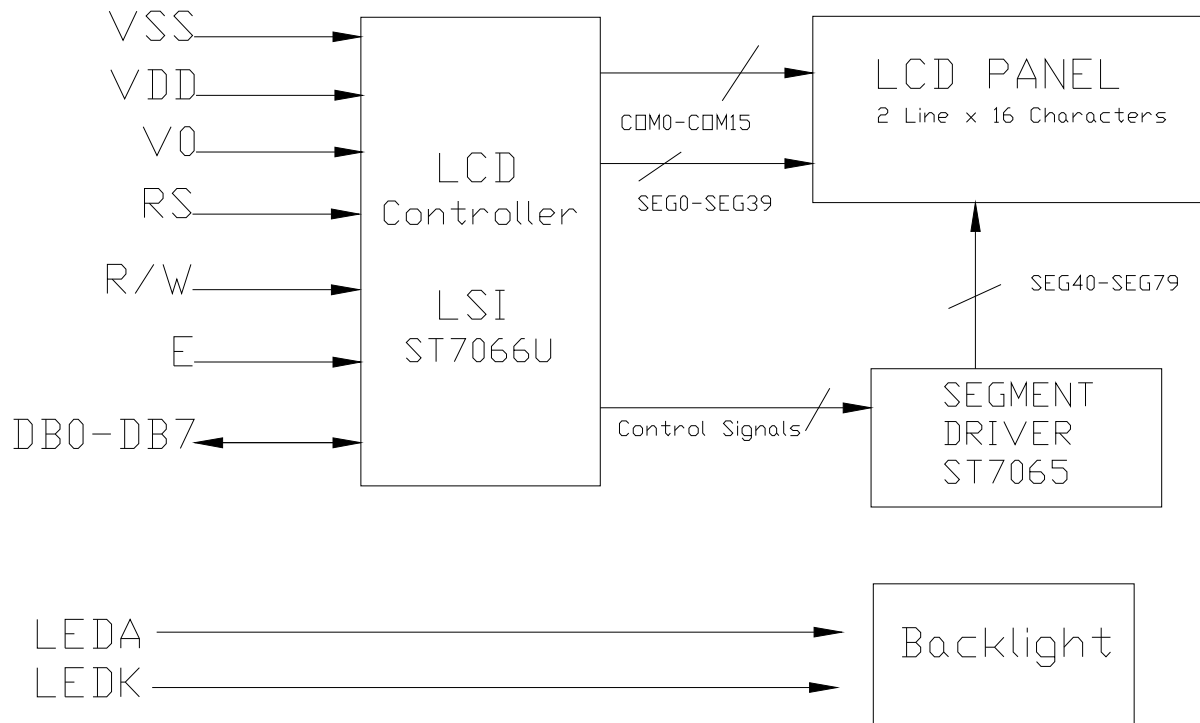

5.PIN DESCRIPTION

Pin No.	Symbol	Function
1	Vss	Ground of chip
2	VDD	Power supply
3	V0	Power supply for LCD Driver
4	RS	Registers selection (H:Data register, L: Instruction register)
5	R/W	Read/ Write selection (H: Read L: Write)
6	E	Enable signal for LCM
7~14	DB0~DB7	Data bus lines
15	LED-(K)	Power supply for backlight
16	LED+(A)	Power supply for backlight (Voltage: TBD)

6.PCB DRAWING AND DESCRIPTION

6-1 PCB DRAWING

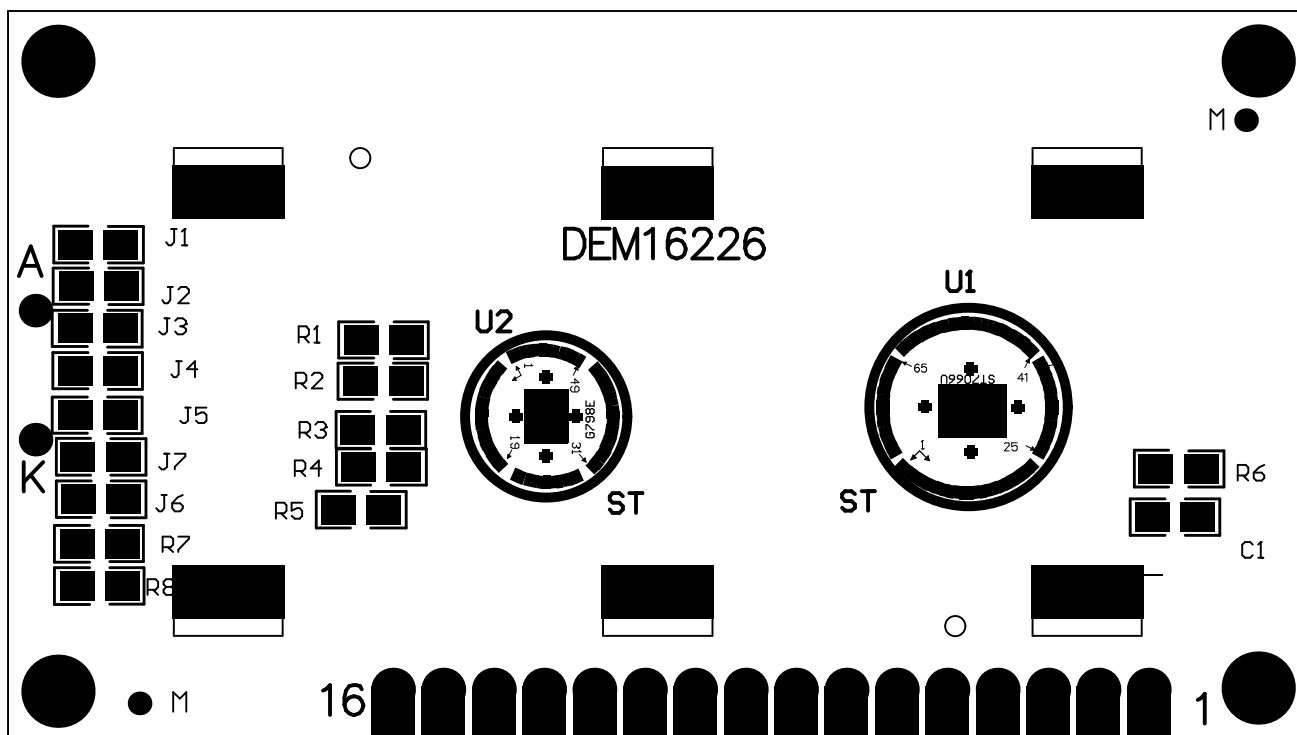

6-2.DESRIPTION:

6-2-1.The polarity of the pin 15 and the pin 16:

J3,J5	J2, J4	LED Polarity	
		15 Pin	16 Pin
Each open	Each closed	Anode	Cathode
Each closed	Each open	Cathode	Anode

Note: In application module: J3=J5=closed, J2=J4=open

6-2-2. The metal-bezel is set on ground when the J1 is closed.

Note: In application module: J1=closed

6-2-3. The LED resistor can be bridged when the J6 is closed.

Note: In application module: J6=open

6-2-4. The R7 and the R8 is the LED resistor.

Note::R8/R7=TBD

6-2-5. The mounting-hole is set be ground when the J7 is closed

Note: In application module, J7=closed

7. BACKLIGHT ELECTRICAL/OPTICAL SPECIFCATIONS

Item	Symbol	MIN.	TYP.	MAX.	Unit	Condition
Forward Voltage	Vf	-	2.8	3.2	V	T=25°C If=20mA
Forward Current	If	-	20	-	mA	
Colour Coordinate	X	0.25		0.33		
	Y	0.25		0.33		
Luminance	Lv	1000	1500	-	cd/m²	
Uniformity	Avg	75			%	
Half Life Expectancy	LI		50000		H	

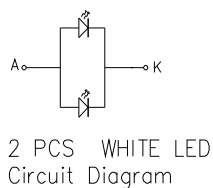
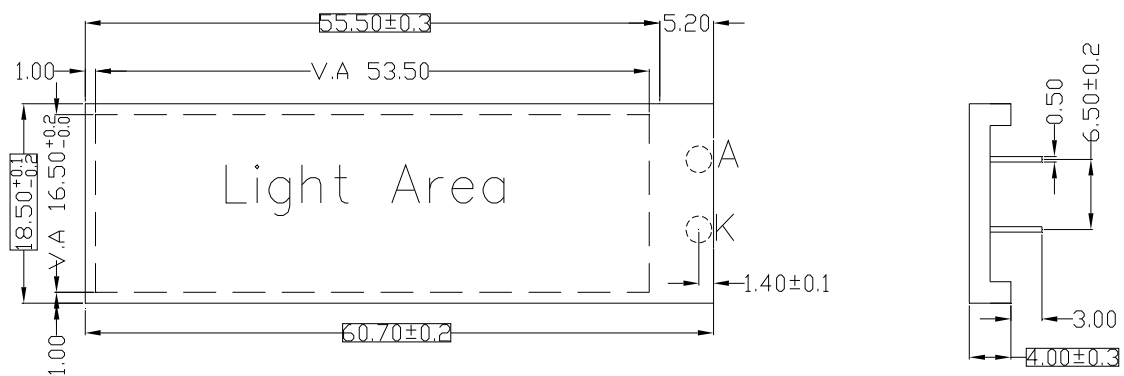

- Remarks:
1. Unmarked tolerance is ±0.3
 2. All materials comply with RoHs
 3. : critical dimension.

8. MAXIMUM ABSOLUTE POWER RATINGS

Item	Symbol	Min	Max	Unit
Power supply voltage	V _{DD}	-0.3	7	V
LCD Driver voltage	V ₀	V _{DD} -10.0	V _{DD} +0.3	V
Input Voltage	V _{IN}	-0.3	V _{DD} +0.3	V
Operating temperature	T _{op}	-20	+70	°C
Storage temperature	T _{st}	-30	+80	°C

9. ELECTRICAL CHARACTERISTICS

9-1. DC Characteristics (VDD=5.0V)

Item	Symbol	Standard Value			Unit
		MIN	TYP	MAX	
Operating Voltage	V _{DD}	4.7	5.0	5.3	V
LCD Voltage	V _{OP}	4.2	4.5	4.8	V
Supply Current	I _{DD}	----	TBD	----	mA

9-2 .AC Characteristics

9-2-1 Write Mode

Characteristic	Symbol	Min	Type	Max	Unit	Test PIN
E Cycle Time	t _c	1200	---	---	ns	E
E Rise Time	t _R	---	---	25	ns	E
E Fall Time	t _F	---	---	25	ns	E
E Pulse width	t _{pw}	140	---	---	ns	E
Address Setup Time	t _{AS}	0	---	---	ns	R/W,RS,E
Address Hold Time	t _{AH}	10	---	---	ns	R/W,RS,E
Data Setup Time	T _{DSW}	40	---	---	ns	DB0~DB7
Data Hold Time	t _H	10	---	---	ns	DB0~DB7

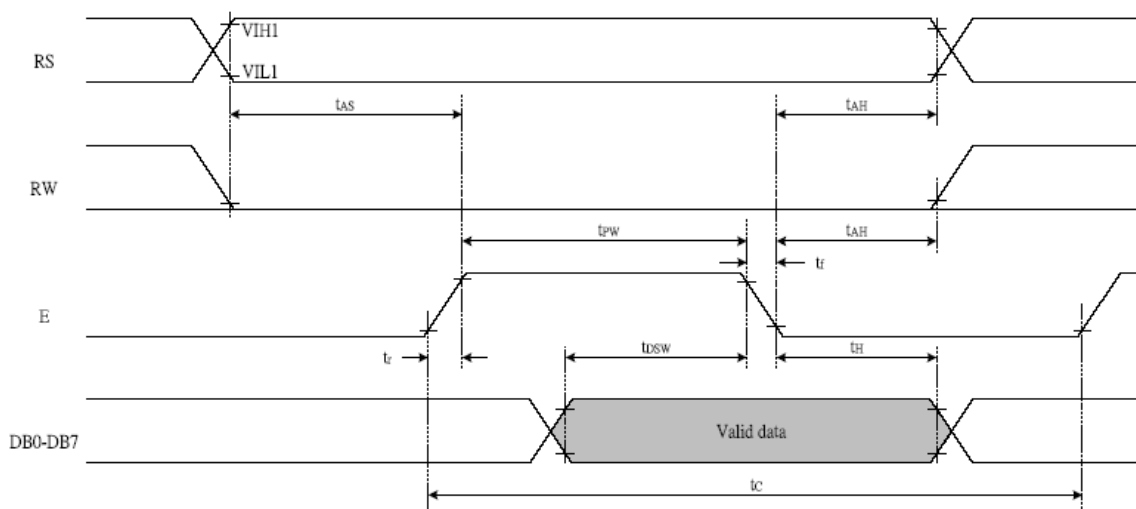

9-2-2 Read Mode

Characteristic	Symbol	Min	Type	Max	Unit	Test PIN
E Cycle Time	t_C	1200	---	---	ns	E
E Rise Time	t_R	---	---	25	ns	E
E Fall Time	t_F	---	---	25	ns	E
E Pulse width	t_{PW}	140	---	---	ns	E
Address Setup Time	t_{AS}	0	---	---	ns	R/W,RS,E
Address Hold Time	t_{AH}	10	---	---	ns	R/W,RS,E
Data Setup Time	t_{DDR}	40	---	---	ns	DB0~DB7
Data Hold Time	t_H	10	---	---	ns	DB0~DB7

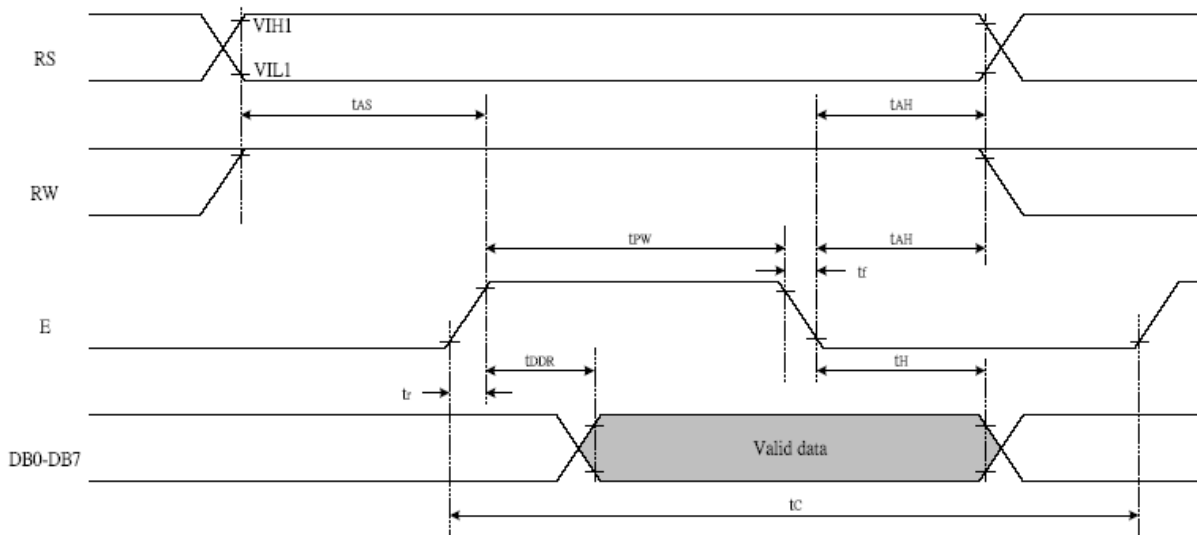

10. CONTOL AND DISPLAY COMMAND

Command	RS	R/W	DB7	DB6	DB5	DB4	DB3	DB2	DB1	DB0	Execution time (fosc=270KHz)	Remark
Clear Display	0	0	0	0	0	0	0	0	0	1	1.52ms	Write"20H" to DDRAM. And set DDRAM address to "00H" from AC
Return home	0	0	0	0	0	0	0	0	1	x	1.52ms	Set DDRAM address to "00H" from AC and return cursor to its original position if shifted. The contents of DDRAM are not changed.
Entry mode Set	0	0	0	0	0	0	0	1	I/D	S	37us	Sets cursor move direction and specifies display shift. These operations are performed during data write and read.
Display on/off control	0	0	0	0	0	0	1	D	C	B	37us	D=1: entire display on C=1: cursor on B=1: cursor position on
Cursor or Display Shift	0	0	0	0	0	1	S/C	R/L	x	x	37us	Set cursor moving and display shift control bit, and the direction, without changing DDRAM data.
function Set	0	0	0	0	1	DL	N	F	x	x	37us	DL: interface data is 8/4 bits N: number of line is 2/1 F: font size is 5x11/5x8
Set CGRAM address	0	0	0	1	AC5	AC4	AC3	AC2	AC1	AC0	37us	Set CGRAM address in address counter
Set DDRAM address	0	0	1	AC6	AC5	AC4	AC3	AC2	AC1	AC0	37us	Set DDRAM address in address counter
Read busy flag& address	0	1	BF	AC6	AC5	AC4	AC3	AC2	AC1	AC0	0us	Whether during internal operation or not can be known by reading BF. The contents of address counter can also be read.
Write data to RAM	1	0	D7	D6	D5	D4	D3	D2	D1	D0	37us	Write data into internal RAM (DDRAM/CGRAM)
Read data from RAM	1	1	D7	D6	D5	D4	D3	D2	D1	D0	37us	Read data from internal RAM (DDRAM / CGRAM)

Note:

Be sure the ST7066U is not in the busy state (BF=00 before sending an instruction from the MPU to the ST7066U. If an instruction is sent without checking the busy flag, the time between the first instruction and next instruction will take much longer than the instruction time itself. Refer to instruction table for the list of each instruction execution time.

11. STANDARD CHARACTER PATTERN(ST7066U-0A)

High bit	Low bit	0000	0001	0010	0011	0100	0101	0110	0111	1000	1001	10010	1011	1100	1101	1110	1111
	0000	CG RAM (1)		0	1	2	3	4	5				6	7	8	9	0
	0001	(2)	!	1	A	Q	a	n				h	f	4	3		
	0010	(3)	"	2	B	R	b	r				F	4	7	x	p	0
	0011	(4)	*	3	C	S	c	s				J	o	T	E	e	o
	0100	(5)	*	4	D	T	d	t				V	1	K	1	u	o
	0101	(6)	%	5	E	U	e	u				=	7	6	2	o	0
	0110	(7)	&	6	F	V	f	v				9	0	1	3	p	2
	0111	(8)	'	7	G	W	g	w				7	7	2	7	g	π
	1000	(1)	(8	H	X	h	x				4	o	*	U	J	2
	1001	(2))	9	I	Y	i	y				5	7	J	U	V	U
	1010	(3)	*	*	J	Z	j	z				3	0	0	V	J	7
	1011	(4)	+	*	K	L	k	l				*	9	E	0	*	π
	1100	(5)	.	<	L	*	l	l				6	E	7	7	o	π
	1101	(6)	—	=	M	I	m	i				2	2	2	2	2	+
	1110	(7)	·	>	N	^	n	^				3	E	7	π	π	
	1111	(8)	/	?	O	_	o	*				5	U	7	π	0	■

12. ELECTRO-OPTICAL DEFINITION

Optical Characteristics

Item	Symbol	Description	Condition	Min	Typ	Max	Unt
Operating Voltage of LCD	V_{LCD}	---	$T_a=+25^{\circ}C$	---	4.5	---	V
Response time	T_r	Rise	$25^{\circ}C$	---	150	---	ms
	T_f	Fall	$25^{\circ}C$	---	110	---	ms
Contrast	Cr		$V_{LCD}=4.5V\pm 3\%.25^{\circ}C$	---	15	---	
Viewing angle	θ	6 o'clock axis	$C_r \geq 2.0$ $V_{LCD}=4.5V\pm 3\%.25^{\circ}C$	---	40	---	deg
		12 o'clock axis	$V_{LCD}=4.5V\pm 3\%.25^{\circ}C$	---	30	---	deg
		3 o'clock axis	$V_{LCD}=4.5V\pm 3\%.25^{\circ}C$	---	40	---	deg
		9 o'clock axis	$V_{LCD}=4.5V\pm 3\%.25^{\circ}C$	---	40	---	deg

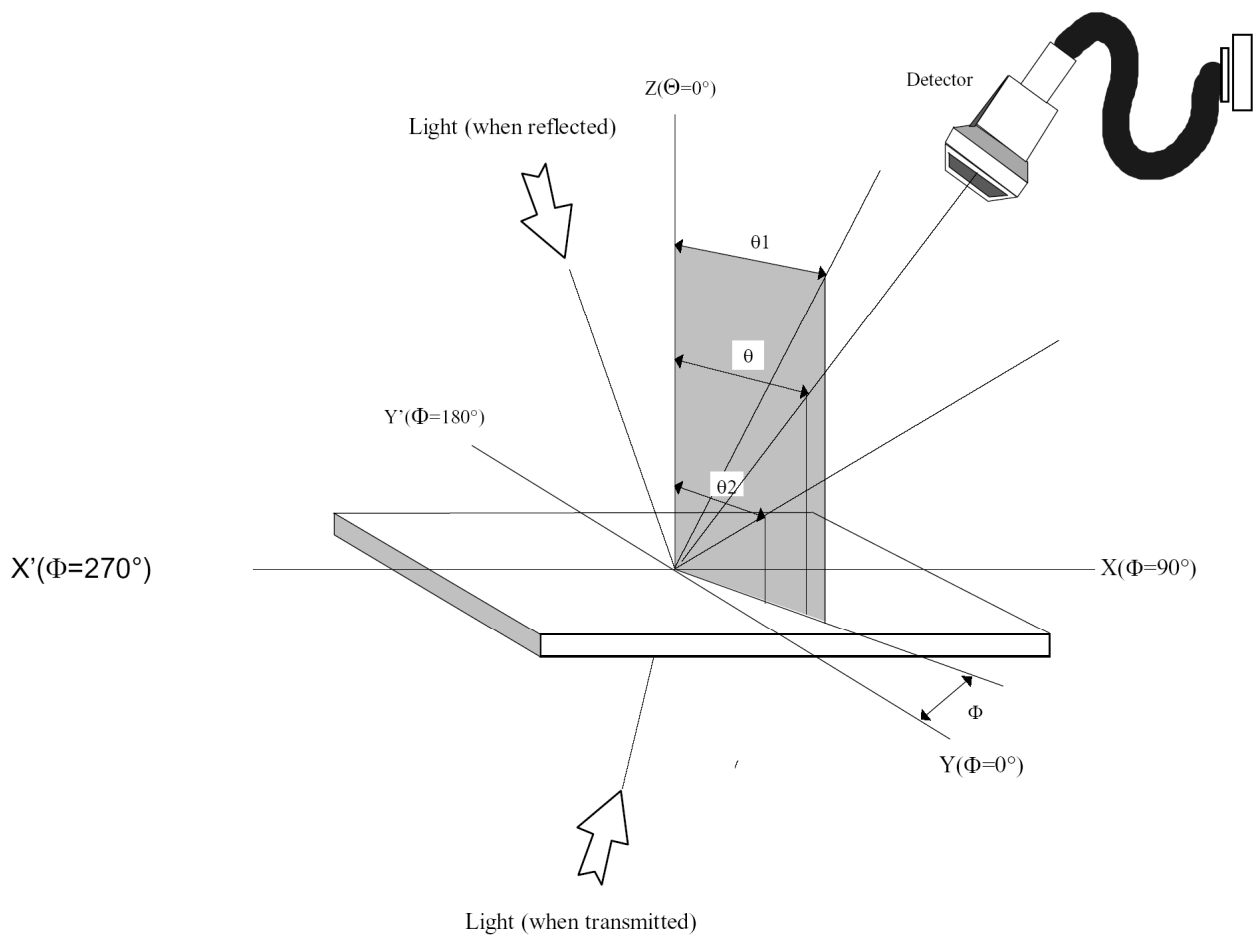

Definition of contrast $Cr. = \frac{B2}{B1} = \frac{\text{Bright curve of not selected segment}}{\text{Bright curve of selected segment}}$

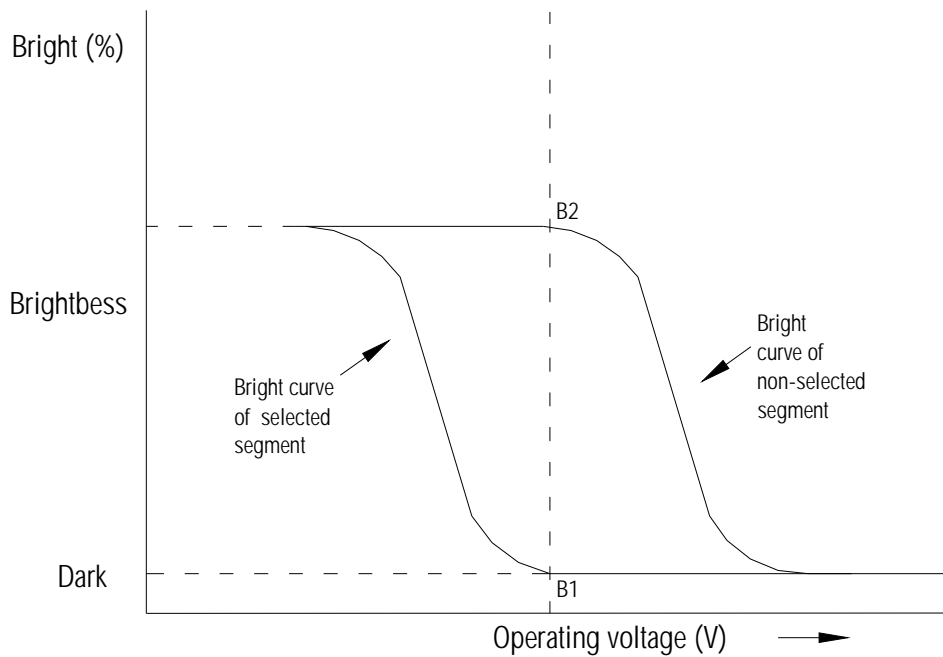

Definition of viewing angle $\theta 1$ and $\theta 2$

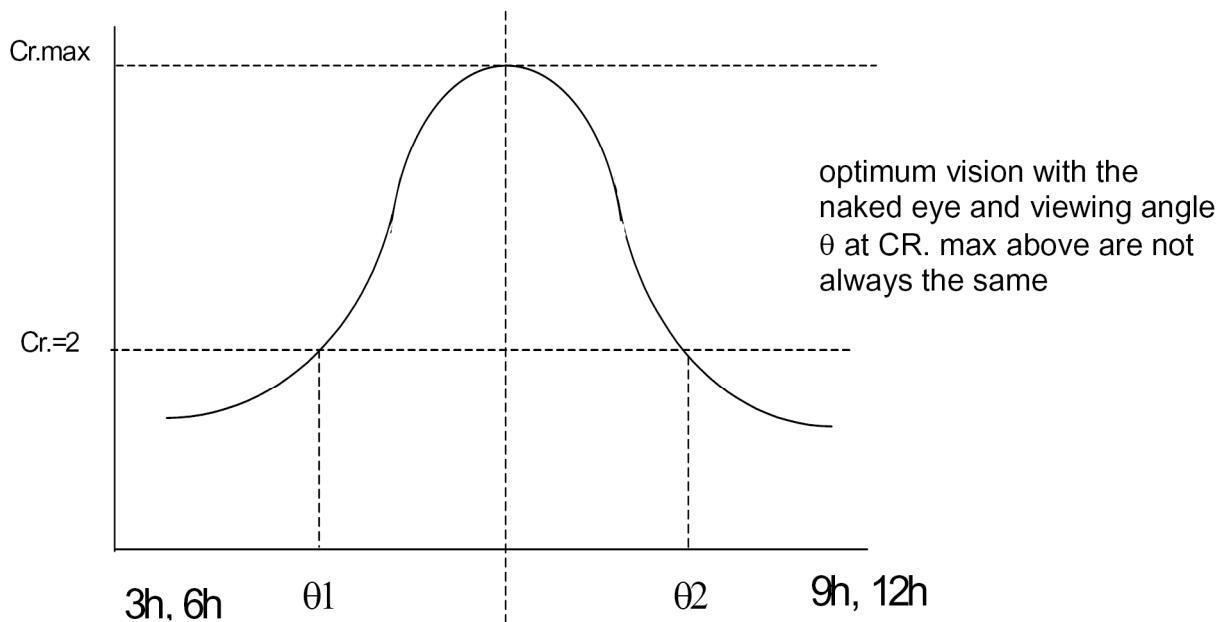

13. QUALITY DESCRIPTION

DEFECT SPECIFICATION:

Specific type-related items are covered in this sheet.

- a: Table for Cosmetic defects
(Note: nc = not counted).
Sizes and number of defects
(Max. Qty)

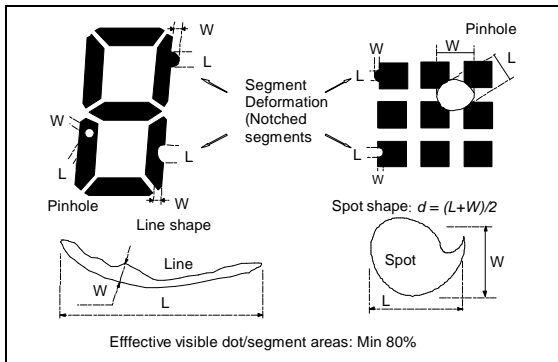

Shapes

- b: Glass defects
- b1: Glass defects at contact ledge

b2: Glass chipping in other areas shall not be in conflict with the product's function.

Defect Type	Max. defect size [μm] d or L W	Max. Quantity
Black or White Spots	$d \leq 100$	nc
	$100 < d \leq 200$	5
Black or White Lines	-- $W \leq 10$	nc
	$L \leq 5000$ $W \leq 30$	3
	$L \leq 2000$ $W \leq 50$	2
Pinhole	$d \leq 100$	nc
	$100 < d \leq 200$	1/segment
(Total defects)		(5)
Segment Deformation	$W \leq 100$	nc
Bubble (e.g. under pola)	$d \leq 150$	nc
	$200 < d \leq 400$	3
	$400 < d \leq 600$	1

Examples/

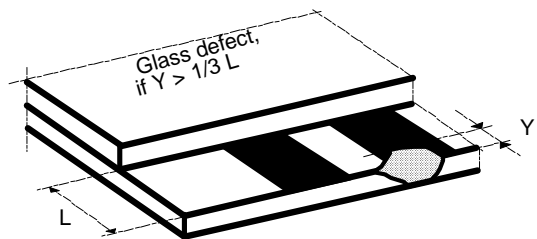

14. RELIABILITY TEST

Operating life time: Longer than 50000 hours(at room temperature without direct irradiation of sunlight)

Reliability characteristics shall meet following requirements.

TEMPERATURE TESTS	NORMAL GRADE
High temperature storage	+80°C x 96hrs
Low temperature storage	-30°C x 96hrs
High temperature operation	+70°C x 96hrs
Low temperature operation	-20°C x 96hrs
High temperature, High humidity	+60°C x 95%RH *96hrs
Thermal shock	-20°C x 30min. ← 10s ↓ 5Cycles +70°C *30min. —
Vibration test	Frequency x Swing x Time 40Hz x 4mm x 4hrs
Drop test	Drop height x Times 1.0m x 6times

15. LCD MODULES HANDLING PRECAUTIONS

- n Please remove the protection foil of polarizer before using.
- n The display panel is made of glass. Do not subject it to a mechanical shock by dropping it from a high place, etc.
- n If the display panel is damaged and the liquid crystal substance inside it leaks out, do not get any in your mouth. If the substance come into contact with your skin or clothes promptly wash it off using soap and water.
- n Do not apply excessive force to the display surface or the adjoining areas since this may cause the color tone to vary.
- n The polarizer covering the display surface of the LCD module is soft and easily scratched. Handle this polarize carefully.
- n To prevent destruction of the elements by static electricity, be careful to maintain an optimum work environment.
 - Be sure to ground the body when handling the LCD module.
 - Tools required for assembly, such as soldering irons, must be properly grounded.
 - To reduce the amount of static electricity generated, do not conduct assembly and other work under dry conditions.
 - The LCD module is coated with a film to protect the display surface. Exercise care when peeling off this protective film since static electricity may be generated.
- n Storage precautions

When storing the LCD modules, avoid exposure to direct sunlight or to the light of fluorescent lamps. Keep the modules in bags designed to prevent static electricity charging under low temperature / normal humidity conditions (avoid high temperature / high humidity and low temperatures below 0°C).Whenever possible, the LCD modules should be stored in the same conditions in which they were shipped from our company.

16. OTHERS

- n** Liquid crystals solidify at low temperature (below the storage temperature range) leading to defective orientation of liquid crystal or the generation of air bubbles (black or white). Air bubbles may also be generated if the module is subjected to a strong shock at a low temperature.

- n** If the LCD modules have been operating for a long time showing the same display patterns may remain on the screen as ghost images and a slight contrast irregularity may also appear. Abnormal operating status can be resumed to be normal condition by suspending use for some time. It should be noted that this phenomena does not adversely affect performance reliability.

- n** To minimize the performance degradation of the LCD modules resulting from caused by static electricity, etc. exercise care to avoid holding the following sections when handling the modules:
 - Exposed area of the printed circuit board
 - Terminal electrode sections