

Display Elektronik GmbH

DATA SHEET

TFT- MODULE

DEM 1280800B TMH-PW-N

10,1" TFT

Product Specification

Ver.: 1

17.02.2017

Revise Records

Rev.	Date	Contents	Written	Approved
0	14.11.2016	Preliminary Specification	MH	MH
1	17.02.2017	Update Backlight Specification	MH	MH

Special Notes

Note1.	
Note2.	
Note3.	
Note4.	
Note5.	

Contents

1. General Description and Features	4
1.1 Features	4
1.2 LCD Module	4
2. Mechanical Information	4
3. Absolute Max. Ratings	5
3.1 Absolute Ratings of Environment	5
3.2 Absolute Ratings of Electrical	5
4. Electrical Characteristics	6
4.1 TFT-LCD Module	6
4.2 Backlight Unit	9
5. Input Terminal Pin Assignment	10
5.1 Pin Assignment	10
6. Optical Characteristics	11
7. Interface Timing	13
7.1 Horizontal Timing Sequence	13
7.2 Vertical Timing Sequence	13
7.3 LVDS Input Data mapping	14
7.4 Color Data Reference	14
8. Reliability Condition	15
9. DIMENSIONAL OUTLINE	16
10. Incoming Inspection Standards	17
10.1 Inspection and Environment Conditions	17

1. General Description and Features

This TFT is a 10.1" color TFT-LCD (Thin Film Transistor Liquid Crystal Display) module composed of LCD panel, driver ICs, control circuit and LED backlight. By applying 1280x800 images are displayed on the 10.1" diagonal screen. Display 16.2M colors by R.G.B signal input.

1.1 Features

- 1280 x 800 pixels resolution.
- Brightness: 1500cd/m2
- LED-Lifetime: min. 50.000h
- Display in 16.2M colors.
- RoHS Compliance

1.2 LCD Module

Item	Specification	Unit
Screen Size	10.1 Inches	Diagonal
Display Resolution	1280 x RGB x 800	Dot
Active Area	216.96 x 135.60	mm
Outline Dimension	230.56 x 155.01 x 6.90	mm
Display Mode	Normally White, TN	--
Pixel Arrangement	RGB-Vertical Stripe	--
Display Color	16.2 Million	--
Surface Treatment	Anti-Glare, 3H	--
Viewing Direction	6 o'clock(Gray Inversion)	--
Input Interface	LVDS	--

2. Mechanical Information

Item		Min.	Typ.	Max.	Unit	Note
Module Size	Horizontal (H)	230.26	230.56	230.86	mm	--
	Vertical (V)	154.71	155.01	155.31	mm	
	Thickness (T)	6.60	6.90	7.20	mm	(1)
Weight		--	TBD	--	g	--

Note (1) Not include PCB.

Refer to the Outline Dimension for further information.

3. Absolute Max. Ratings

3.1 Absolute Ratings of Environment

If the operating condition exceeds the following absolute maximum ratings, the TFT LCD module may be damaged permanently.

(Ta=25±2°C, V_{SS}=GND=0)

Item	Symbol	Min.	Max.	Unit	Note
Storage Temperature	T _{STG}	-30	+80	°C	(1)
Operating Temperature	T _{OPR}	-20	+70	°C	(1,2,3)

Note (1) 95 % RH Max. (40°C ≥ Ta). Maximum wet-bulb temperature at 39°C or less.
(Ta > 40°C) No condensation.

Note (2) In case of below 0°, the response time of liquid crystal (LC) becomes slower and the color of panel becomes darker than normal one. Level of retardation depends on temperature, because of LC's character

Note (3) Only operation is guaranteed at operating temperature. Contrast, response time, another display quality are evaluated at +25°C.

3.2 Absolute Ratings of Electrical

The following are maximum values which, if exceeded, may cause faulty operation or damage to the unit.

Item	Symbol	Min.	Max.	Unit	Note
LCD Power Voltage	VCC	0	4	V	
Signal Input Voltage	RxIN0+~ RxIN2+ RxIN0~-RxIN2-NINC Rx CLK IN +/-	-0.3	VCC+0.3	V	

4. Electrical Characteristics

4.1 TFT-LCD Module

ITEM	SYMBOL	MIN	TYP	MAX	UNIT	NOTE
LCD Power Voltage	VCC	3.0	3.3	3.6	V	Note1
LCD Power Current	ICC	-	TBD	(260)	mA	Note2
Rush Current	Irush	-	-	(2)	A	Note4
Logic Input Voltage (LVDS:IN+, IN-)	Common Voltage	$\frac{ VID }{2}$	-	$2.4 - \frac{ VID }{2}$	V	Note3
	Diffusential Input Voltage	VID	200	600	mV	Note3
	Threshold Voltage(HIGH)	VTH	-	100	mV	Note3 When VCM=+1.2V
	Threshold Voltage(LOW)	VTL	-100	-	mV	

【Note】

*1) Power Sequence :

- 0.5 < t1 ≤ 10ms 500ms ≤ t5
- 0 < t2 ≤ 50ms 200ms ≤ t6
- 0 < t3 ≤ 50ms 200ms ≤ t7
- 0 < t4 ≤ 10ms

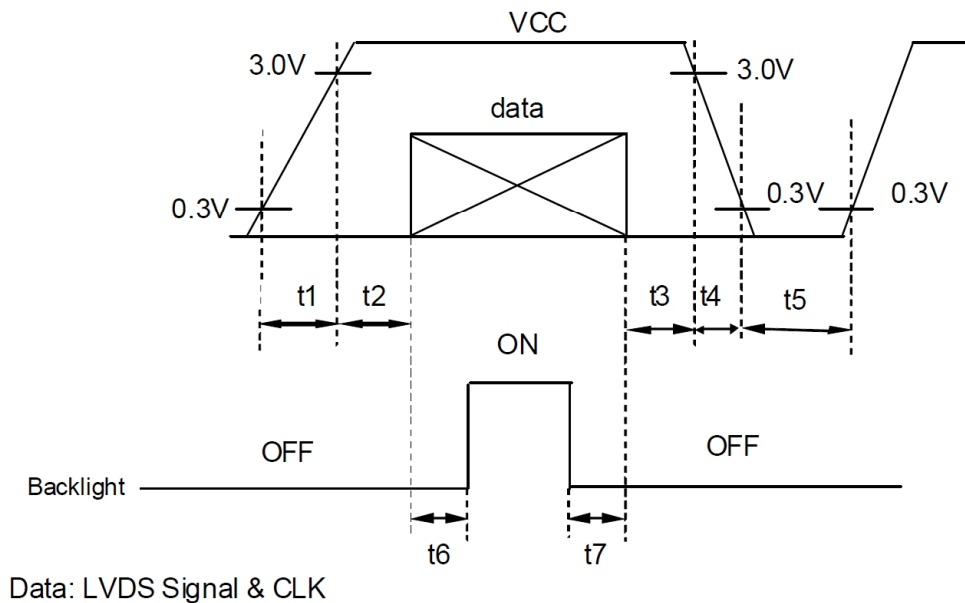

VCC-dip state

(1)when $3.0V > VCC \geq 2.7V$, $t_d \leq 10$ ms.

(2)when $VCC < 2.7V$, VCC-dip condition should as the VCC-turn-off condition.

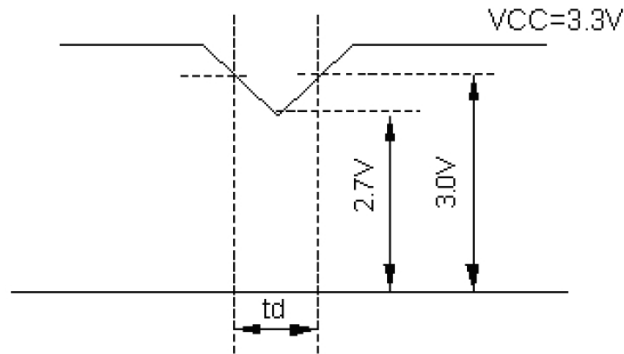

*2)Typ. specification : Gray-level test Pattern
Max. specification : Black test Pattern



(a) Gray-level Pattern

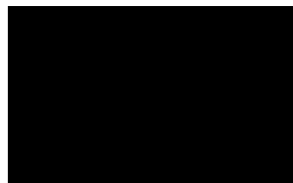

(b) Black Pattern

*3) LVDS Signal Definite :

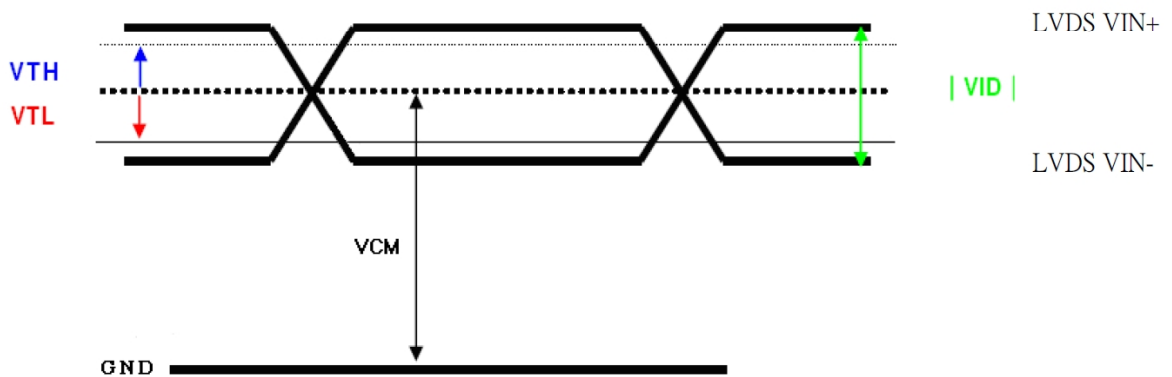

VIN+ : Positive differential DATA & CLK Input
VIN- : Negative differential DATA & CLK Input

*4) Irush measure condition

Control signal: High(+3.3V)→Low(GND)

Supply Voltage of rising time should be from R3 and C2 tune to 470 us.

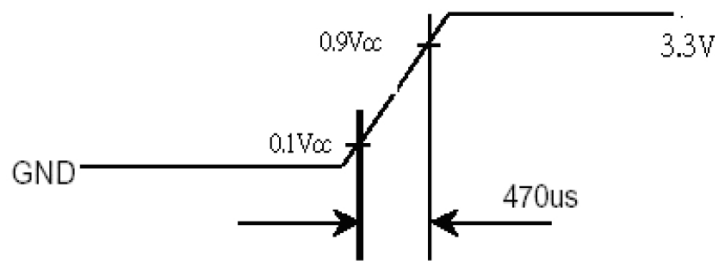
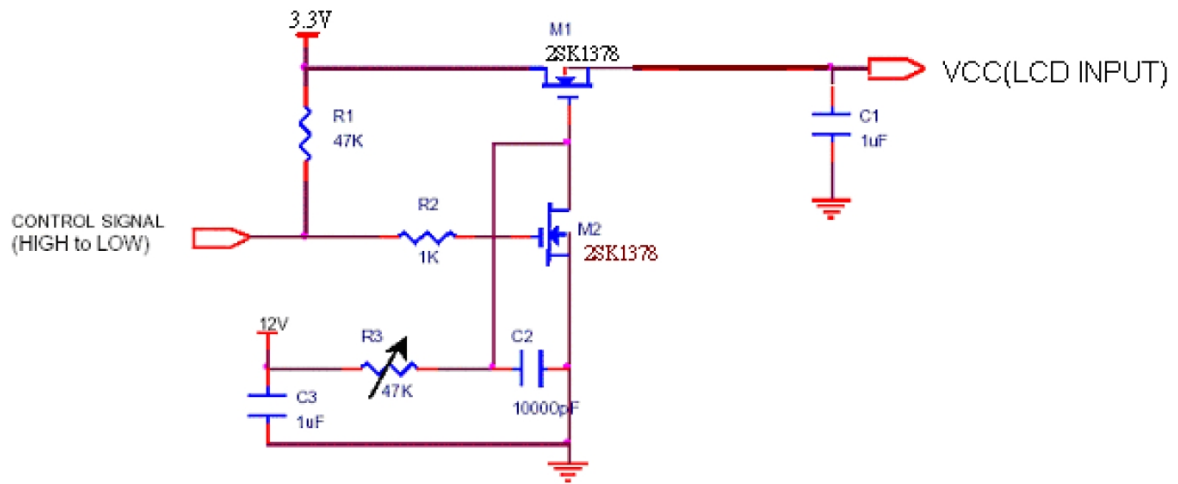

4.2 Backlight Unit

(Ta=25±2°C)

Item	Symbol	Value			Unit	Note
		Min.	Typ.	Max.		
LED Total Input Voltage	VL	11.2	12.0	13.8	V	
LED Total Input Current	IL	-	560	-	mA	
Power Consumption	P _{BL}	-	6.72	7.73	W	
LED Lifetime	-	50,000	-	-	Hrs	

Note (1) LEDs in 4 Series x 8 Parallel Type.

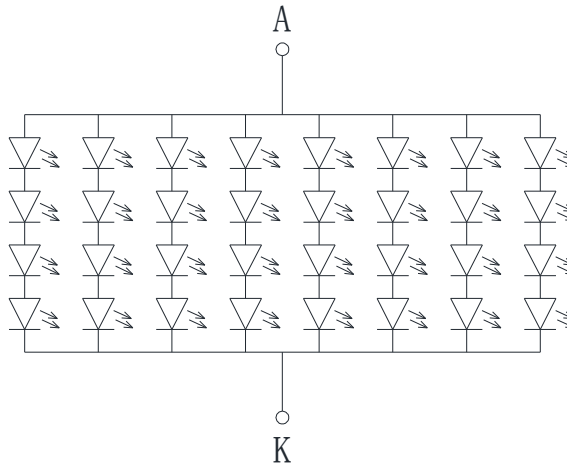

(2) Where $IL = 560\text{mA}$, $VL = 12$, $P_{BL} = VB \times IB$

(3) The environmental conducted under ambient air flow, at $Ta=25^\circ\text{C}\pm 2^\circ\text{C}$, $60\%\text{RH}\pm 5\%$

5. Input Terminal Pin Assignment**5.1 Pin Assignment**

Pin No.	Symbol	Function	Remark
1	Anode	LED Output	
2	Anode	LED Output	
3	Anode	LED Output	
4	NC	No Connect	
5	NC	No Connect	
6	NC	No Connect	
7	NC	No Connect	
8	Cathode	LED Feedback	
9	Cathode	LED Feedback	
10	Cathode	LED Feedback	
11	NC	No Connect	
12	NC	No Connect	
13	GND	Ground	
14	NC	No Connect	
15	NC	No Connect	
16	GND	Ground	
17	NC	No Connect	
18	NC	No Connect	
19	GND	Ground	
20	RxIN3+	LVDS Signal(+)-channel 3	
21	RxIN3-	LVDS Signal(-)-channel 3	
22	GND	Ground	
23	RxCLKIN+	LVDS Clock Signal(+)	
24	RxCLKIN-	LVDS Clock Signal(-)	
25	GND	Ground	
26	RxIN2+	LVDS Signal(+)-channel 2	
27	RxIN2-	LVDS Signal(-)-channel 2	
28	GND	Ground	
29	RxIN1+	LVDS Signal(+)-channel 1	
30	RxIN1-	LVDS Signal(-)-channel 1	
31	GND	Ground	
32	RxIN0+	LVDS Signal(+)-channel 0	
33	RxIN0-	LVDS Signal(-)-channel 0	
34	GND	Ground	
35	NC	No Connect	
36	NC	No Connect	
37	NC	No Connect	
38	VCC	+3.3v Power	
39	VCC	+3.3v Power	
40	NC	No Connect	

Connector Part Name : 5-2069716-3 (TYCO)

6. Optical Characteristics

Item	Symbol	Condition	Min	Type	Max	Unit	Note	
Brightness	B		1350	1500	--	cd/m ²		
Response Time (White - Black)	Tr +Tf	$\theta=0^\circ$	--	30	45	ms		
Contrast Ratio	CR	At optimized viewing angle	400	600	--	--		
Luminance Uniformity	ΔL		75	80		%		
Color Chromaticity (CIE 1931)	White	Wx	$\theta=0^\circ$ Normal Viewing Angle	0.275	0.315	0.355	--	BM-7A
		Wy		0.302	0.342	0.382		
Viewing Angle (6H)	Ver.	θ_U	CR \geq 10	60	70	--	Degree	
		θ_D		50	60	--		
	Hor.	θ_L		60	70	--		
		θ_R		60	70	--		

a. Test equipment setup

After stabilizing and leaving the panel alone shall be warmed up for the stable operation of LCM, the measurement should be executed. Measurement should be executed in a stable, windless, and dark room. Optical specifications are measured by Topcon BM-7(fast) with a viewing angle of 2° at a distance of 50cm and normal direction.

b. Definition of response time: Tr and Tf

The response time is defined as the following figure and shall be measured by switching the input signal for "black" and "white".

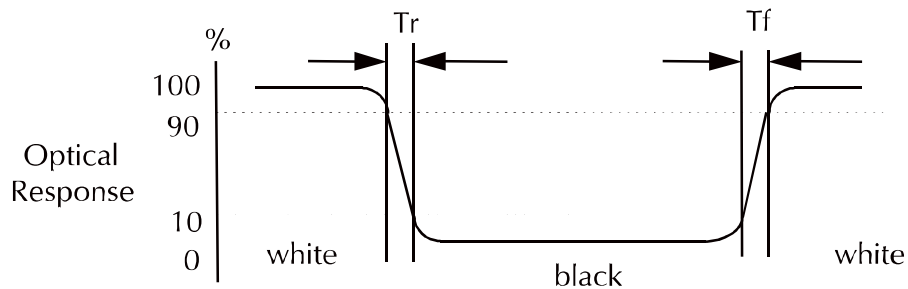

c. Definition of contrast ratio:

$$\text{Contrast Ratio (CR)} = \frac{\text{Brightness measured when LCD is at "white state"}}{\text{Brightness measured when LCD is at "black state"}}$$

d. Measured at the center area of the panel when all the input terminals of LCD panel are electrically opened.

e. View Angle

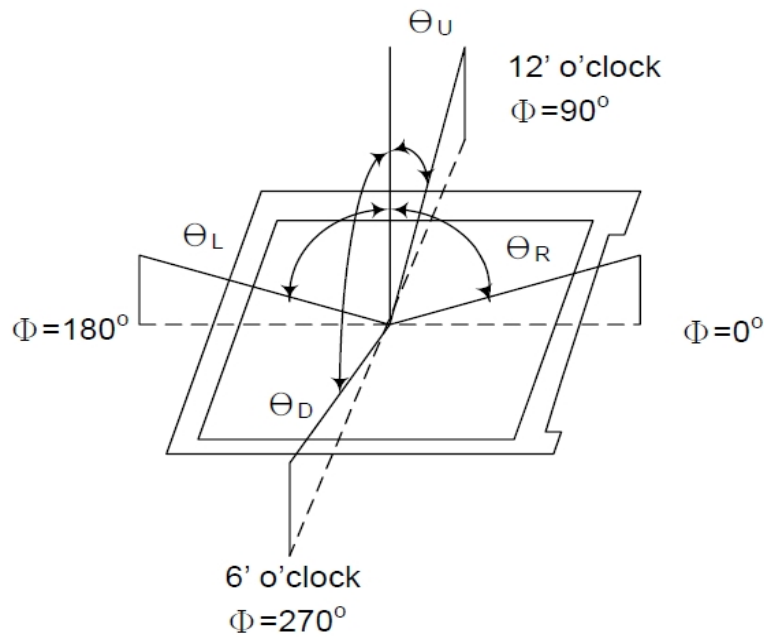

f. Definition of Luminance of White: Luminance of white at the center points

Light Source of Back-Light Unit	LED Type
---------------------------------	----------

g. Definition of White Uniformity

$$\text{White Uniformity} = \frac{\text{Min. luminance of white among 9-points}}{\text{Max. luminance of white among 9-points}} \times 100\%$$

h. The definition of Color Gamut -Color Chromaticity CIE 1931

Color coordinate of white & red, green, blue at center point.

Color Gamut : NTSC(%) = (RGB Triangle Area / NTSC Triangle Area) x 100

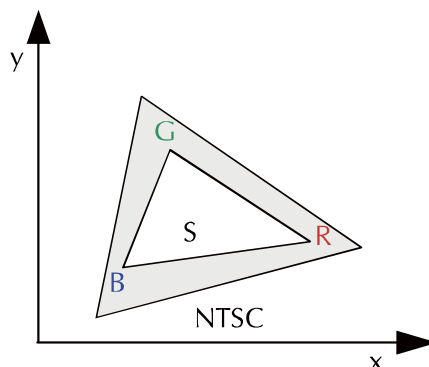

7. Interface Timing

ITEM		SYMBOL	MIN	TYP	MAX	UNIT	
LVDS input signal sequence	CLK Frequency	tclk	66.6	72.40	78.9	MHz	
LCD input signal sequence (Input LVDS Transmitter)	Horizontal	Horizontal total Time	t _H	1370	1440	1500	tCLK
		Horizontal effective Time	t _{HA}	1280			tCLK
		Horizontal Blank Time	t _{HB}	90	160	220	tCLK
	Vertical	Vertical total Time	t _V	810	838	877	t _H
		Vertical effective Time	t _{VA}	800			t _H
		Vertical Blank Time	t _{VB}	10	38	77	t _H

【Note】

- *1) DENA (DATA ENABLE) usually is positive.
- *2) During the whole blank period, DCLK should keep input.

7.1 Horizontal Timing Sequence

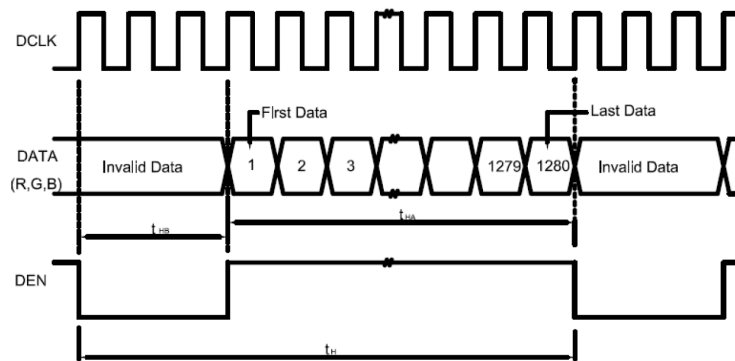

7.2 Vertical Timing Sequence

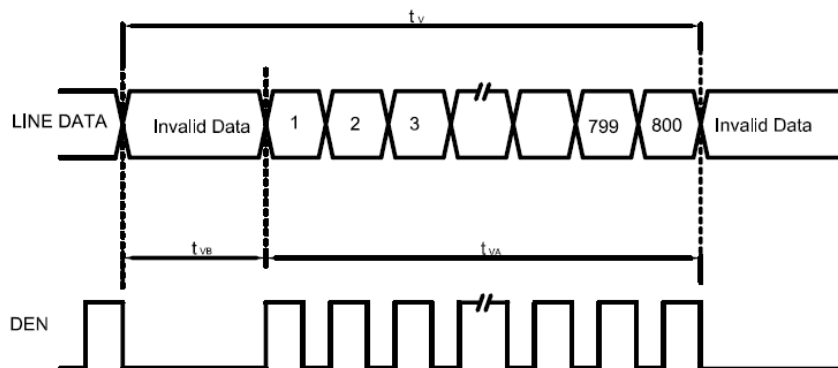

7.3 LVDS Input Data mapping

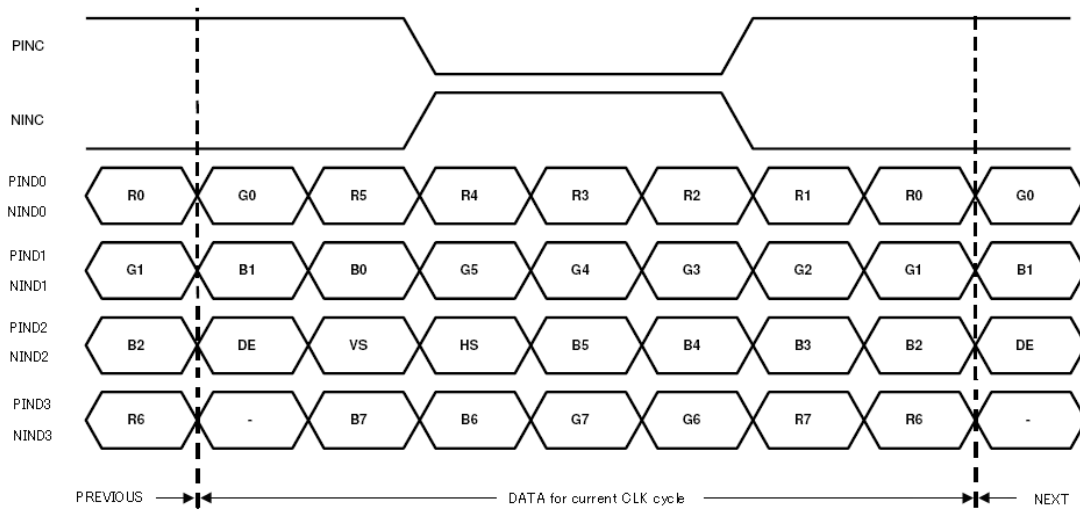

7.4 Color Data Reference

COLOR	INPUT DATA	R DATA								G DATA								B DATA							
		R7	R6	R5	R4	R3	R2	R1	R0	G7	G6	G5	G4	G3	G2	G1	G0	B7	B6	B5	B4	B3	B2	B1	B0
		MSB						LSB	MSB							LSB	MSB								LSB
BASIC COLOR	BLACK	0	0	0	0	0	0	0	0	0	0	0	0	0	0	0	0	0	0	0	0	0	0	0	0
	RED(255)	1	1	1	1	1	1	1	1	0	0	0	0	0	0	0	0	0	0	0	0	0	0	0	0
	GREEN(255)	0	0	0	0	0	0	0	0	1	1	1	1	1	1	1	1	0	0	0	0	0	0	0	0
	BLUE(255)	0	0	0	0	0	0	0	0	0	0	0	0	0	0	0	0	1	1	1	1	1	1	1	1
	CYAN	0	0	0	0	0	0	0	0	1	1	1	1	1	1	1	1	1	1	1	1	1	1	1	1
	MAGENTA	1	1	1	1	1	1	1	1	0	0	0	0	0	0	0	0	1	1	1	1	1	1	1	1
	YELLOW	1	1	1	1	1	1	1	1	1	1	1	1	1	1	1	1	0	0	0	0	0	0	0	0
	WHITE	1	1	1	1	1	1	1	1	1	1	1	1	1	1	1	1	1	1	1	1	1	1	1	1
RED	RED(0)	0	0	0	0	0	0	0	0	0	0	0	0	0	0	0	0	0	0	0	0	0	0	0	
	RED(1)	0	0	0	0	0	0	0	1	0	0	0	0	0	0	0	0	0	0	0	0	0	0	0	
	RED(2)	0	0	0	0	0	0	1	0	0	0	0	0	0	0	0	0	0	0	0	0	0	0	0	
	RED(254)	1	1	1	1	1	1	1	0	0	0	0	0	0	0	0	0	0	0	0	0	0	0	0	
	RED(255)	1	1	1	1	1	1	1	1	0	0	0	0	0	0	0	0	0	0	0	0	0	0	0	
GREEN	GREEN(0)	0	0	0	0	0	0	0	0	0	0	0	0	0	0	0	0	0	0	0	0	0	0	0	
	GREEN(1)	0	0	0	0	0	0	0	0	0	0	0	0	0	0	1	0	0	0	0	0	0	0	0	
	GREEN(2)	0	0	0	0	0	0	0	0	0	0	0	0	0	1	0	0	0	0	0	0	0	0	0	
	GREEN(254)	0	0	0	0	0	0	0	0	1	1	1	1	1	1	1	0	0	0	0	0	0	0	0	
	GREEN(255)	0	0	0	0	0	0	0	0	1	1	1	1	1	1	1	1	0	0	0	0	0	0	0	
BLUE	BLUE(0)	0	0	0	0	0	0	0	0	0	0	0	0	0	0	0	0	0	0	0	0	0	0	0	
	BLUE(1)	0	0	0	0	0	0	0	0	0	0	0	0	0	0	0	0	0	0	0	0	0	0	1	
	BLUE(2)	0	0	0	0	0	0	0	0	0	0	0	0	0	0	0	0	0	0	0	0	0	1	0	
	BLUE(254)	0	0	0	0	0	0	0	0	0	0	0	0	0	0	0	0	1	1	1	1	1	1	0	
	BLUE(255)	0	0	0	0	0	0	0	0	0	0	0	0	0	0	0	0	1	1	1	1	1	1	1	

8. Reliability Condition

No change on display and in operation under the following test condition.

Condition: Unless otherwise specified, tests will be conducted under the following condition.

Temperature: 20±5°C.

Humidity: 65±5%RH.

Tests will be not conducted under functioning state.

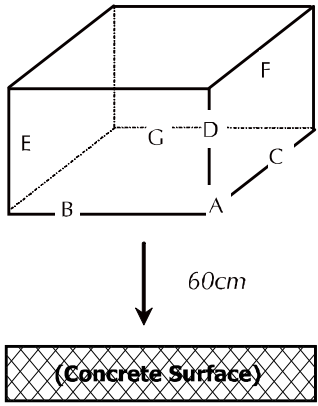
No.	Parameter	Condition	Notes
1	High Temperature Operating	70°C±2°C, 240hrs (Operation state).	
2	Low Temperature Operating	-20°C±2°C, 240hrs (Operation state).	1
3	High Temperature Storage	80°C±2°C, 240hrs.	2
4	Low Temperature Storage	-30°C±2°C, 240hrs.	1,2
5	High Temperature and High Humidity Operation Test	60°C±2°C, 90%, 240hrs.	1,2
6	Vibration Test	Total fixed amplitude: 1.5mm. Vibration Frequency: 10~55Hz. One cycle 60 seconds to 3 direction of X, Y, Z each 15 minutes.	3
7.	Drop Test	To be measured after dropping from 60cm high on the concrete surface in packing state.  <p><i>Dropping method corner dropping:</i></p> <p><i>A corner: Once edge dropping.</i></p> <p><i>B, C, D edge: Once face dropping.</i></p> <p><i>E, F, G face: Once.</i></p>	

- Notes:
1. No dew condensation to be observed.
 2. The function test shall be conducted after 4 hours storage at the normal temperature and humidity after removed from the test chamber.
 3. Vibration test will be conducted to the product itself without putting I in a container.

9. DIMENSIONAL OUTLINE

PIN	SYMBOL	PIN	SYMBOL
1	LEDA	21	RXIN3-
2	LEDA	22	GND
3	LEDA	23	RXCLKIN1
4	VC	24	RXCLKIN-
5	VC	25	GND
6	VC	26	RXIN2+
7	VC	27	RXIN2-
8	LEDK	28	GND
9	LETK	29	RXIN1+
10	LEJK	30	RXIN1-
11	VC	31	GND
12	VC	32	RXIN0+
13	GND	33	RXIN0-
14	VC	34	GND
15	VC	35	NC
16	GND	36	NC
17	VC	37	NC
18	VC	38	VCC
19	GND	39	VCC
20	RXIN3+	40	NC

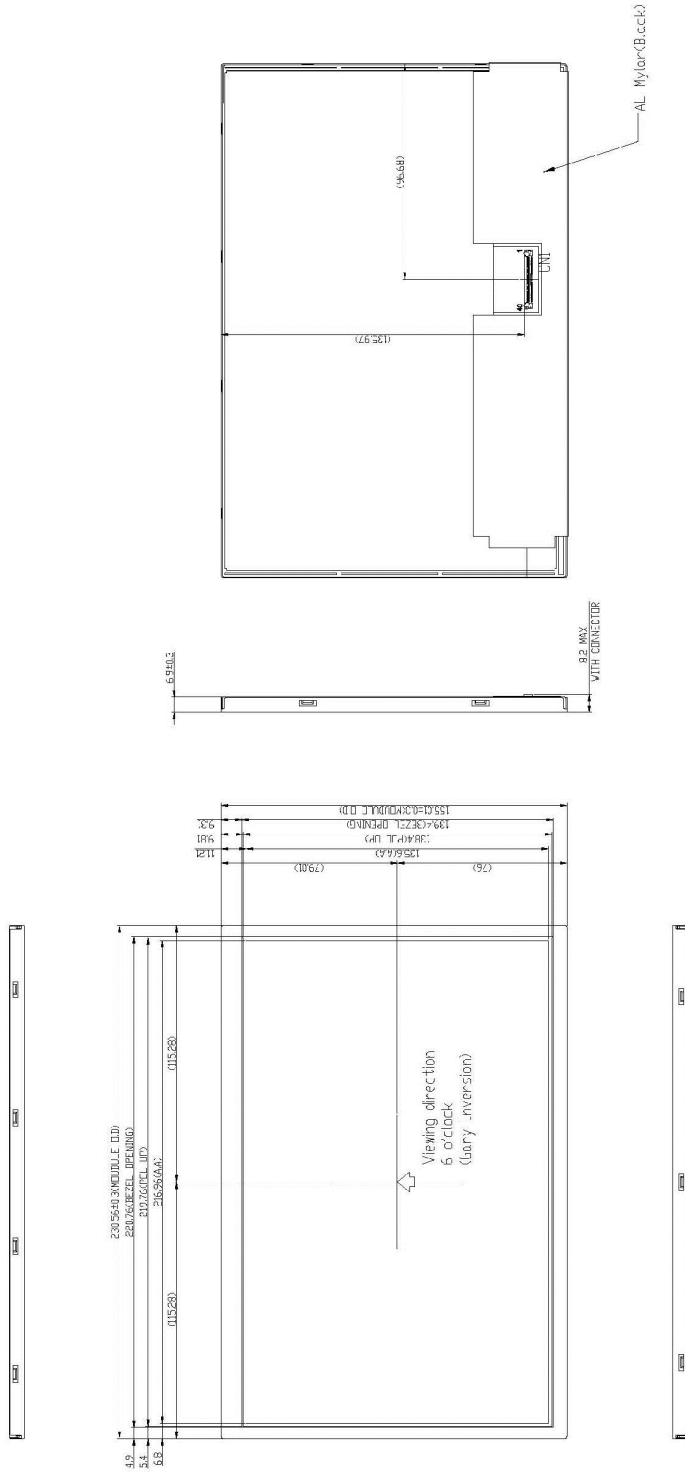

10. Incoming Inspection Standards

10.1 Inspection and Environment Conditions

10.1.1 Inspection Conditions:

- (1) Inspection Distance: 35 cm±5cm
- (2) View Angle : Light-on Inspection Angle : ±5°

Cosmetic Inspection Angle : ±45°

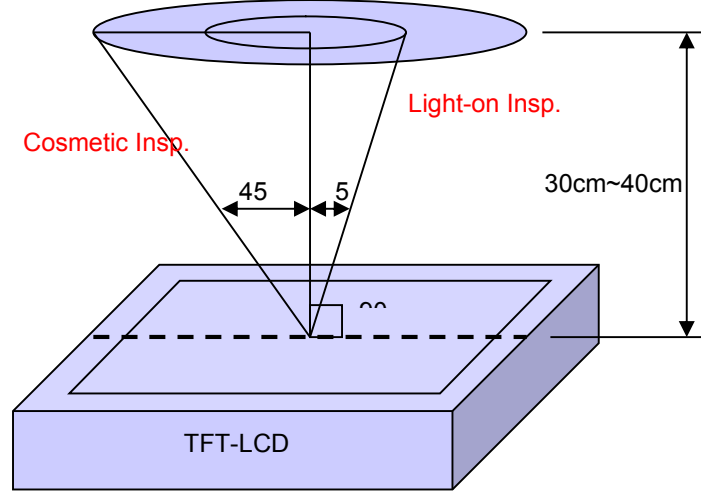

(perpendicular to LCD panel surface)

10.1.2 Environment Conditions:

Ambient Temperature		23°C ±5°C
Ambient Humidity		55±10%RH
Ambient Illumination	Cosmetic Inspection	more than 600 Lux
	Functional Inspection	300~500 Lux

10.1.3 Sampling Conditions:

- (1) Lot Size: Quantity of shipment lot per model
- (2) Sampling Method:

Sampling Plan		MIL-STD-105E
		Normal Inspection, Single Sampling
		Level II
AQL	Major Defect	1.0%
	Minor Defect	1.5%

- (3) The classification of Major(MA) and Minor(MI) defects is shown as 3. Inspection Criteria.

10.1.4 Inspection Criteria

10.1.4.1 Cosmetic Inspection(Panel):

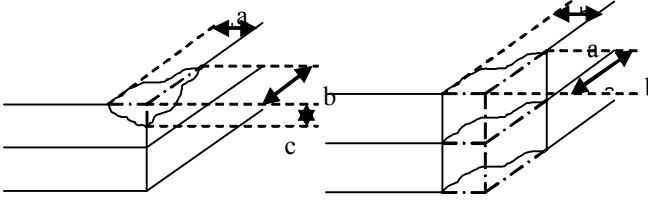
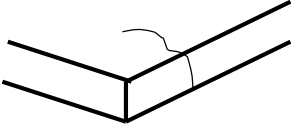
Item	Judgment Criteria	Classification
Chipping on Panel	 <p>$a \leq 3.0\text{mm}$, $b \leq 3.0\text{mm}$, $c \leq t$ (Bottom glass thickness)</p>	MA
Scratch on Panel *Note-2	<p>$W \leq 0.05\text{mm}$ or $L < 5\text{mm}$: Ignored $0.05\text{mm} < W \leq 0.1\text{mm}$ and $L \leq 5\text{mm}$: $N \leq 5$ $W > 0.1\text{mm}$ or $L > 5\text{mm}$: Not allowed</p>	MI
Bubble or Dent on Panel *Note-3	<p>$D \leq 0.2\text{mm}$: Ignored $0.2\text{mm} < D \leq 0.3\text{mm}$: $N \leq 5$ $D > 0.3\text{mm}$: Not allowed</p>	MI
Panel Crack	 <p>Not Allowed crack</p>	MA
Bezel Deformation	Obvious deformation is not allowed.	MI
Bezel Oxidation	Not allowed if it rusts continuously over 1 cm (It is out of warranty with rusted tin plate)	MI
Bezel Scratch	$L \leq 20\text{mm}$, $W \leq 0.2$, $N \leq 3$	MI
Metal Squash Dent /Flange(Front Side)	$D(W) \leq 1, L \leq 3, N \leq 3;$	MI
B/L High Voltage Wire Denudation	Not allowed	MA
Polarizer flaw or leak out resin	Defect is defined as the active area.	MI
Outline Dimension	Must in Spec, refer to related product spec.	MI

10.1.4.2 Functional Inspection:

Item	Judgment Criteria			Classification
	Area(Note1)	I	O	
Point Defect	Bright dot	Random	2	
		2 dots adjacent	0	0
		3 dots adjacent or more	0	0
	Dark dot	Random	3	
		2 dots adjacent	1	
		3 dots adjacent or more	0	0
	Total Dot Defect		5	
	Distance	Distance between Bright and Bright dot	$L \geq 5\text{mm}$	
		Distance between Bright and Dark dot	$L \geq 5\text{mm}$	
		Distance between Dark dot	$L \geq 5\text{mm}$	
(1) It is defined as Point Defect if defect area > 0.5dot (2) It is ignored if defect area $\leq 0.5\text{dot}$ (3) Weak point defect will be defined as Bright Dot if it can be observed through ND filter 5%(Full Screen Black Inspection)				
Line Defect	Obvious vertical or horizontal line defect is not allowed.			MA
Mura	Not allowed if it can be observed through ND Filter 5 %			MI
Foreign Material in spot shape *Note-3	$D \leq 0.2\text{mm}$: Ignored $0.2\text{mm} < D \leq 0.5\text{mm}$: $N \leq 8$ $D > 0.5\text{mm}$: Not allowed			MI
Foreign Material in line or spiral shape *Note-4	$W \leq 0.05\text{mm}$ or $L \leq 5\text{mm}$: Ignored $0.05\text{mm} < W \leq 0.2\text{mm}$ and $L 1.0\text{mm} \leq 5\text{mm}$: $N \leq 8$ $W > 0.2\text{mm}$ or $L > 5\text{mm}$: Not allowed			MI
Display Function Abnormal	No Malfunction can be allowed			MA

Note-1 : I/O Area Definition

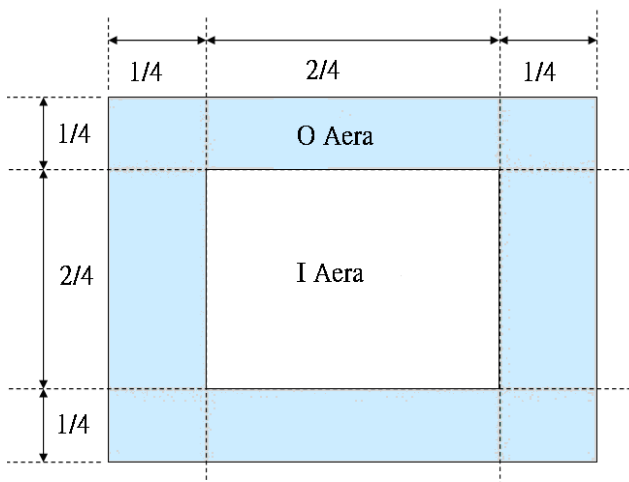

Note-2 : Polarizer Scratch

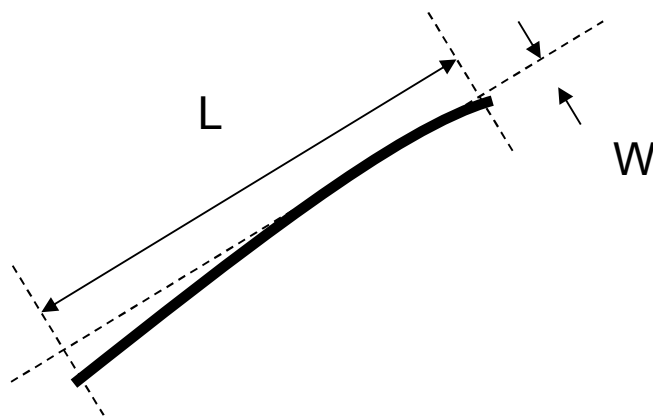

Note-3 : Spot Foreign Material
($W \geq L / 4$)

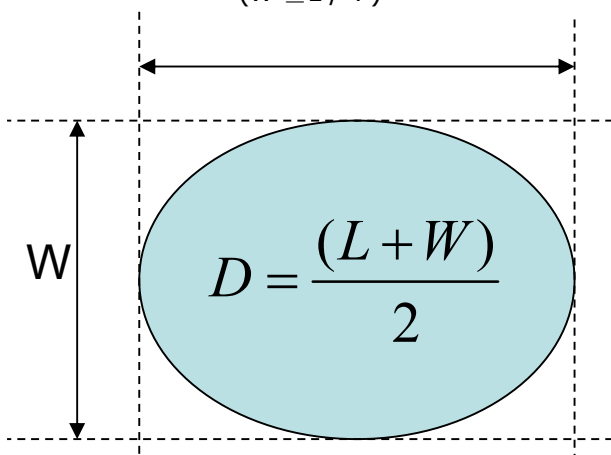

Note-4 : Line or Spiral Foreign Material
($W < L / 4$)

