

DISPLAY Elektronik GmbH

DATA SHEET

LCD MODULE

DEM 12806401 SBH-PW-N

Product Specification

Version: 0

14.08.2021

GENERAL SPECIFICATION

MODULE NO. :

DEM 12806401 SERIES

CUSTOMER P/N:

VERSION NO.	CHANGE DESCRIPTION	DATE
0	Original Version	14.08.2021

PREPARED BY: LM

DATE: 16.08.2021

APPROVED BY: WH

DATE: 16.08.2021

CONTENTS

1. FUNCTIONS & FEATURES.....3

2. MECHANICAL SPECIFICATIONS.....3

3. EXTERNAL DIMENSIONS.....4

4. BLOCK DIAGRAM.....5

5. PIN ASSIGNMENT.....6

6. BACKLIGHT ELECTRICAL/OPTICAL SPECIFICATIONS.....7

7. ABSOLUTE MAXIMUM RATINGS8

8. ELECTRICAL CHARACTERISTICS8

9. COMMAND TABLE.....12

10. LCD ARTWORT13

11. ACCEPT QUALITY LEVEL (AQL)15

12. RELIABILITY TEST.....15

13. LCD MODULES HANDLING PRECAUTIONS.....16

14. OTHERS.....16

1. FUNCTIONS & FEATURES

I DEM 12806401 Series LCD Type :

MODULE	LCD TYPE	REMARK
DEM 12806401 SBH-PW-N	STN-BLUE Transmissive Negative Mode	-

- I Viewing Direction : 6 O'clock
- I Driving Scheme : 1/65 Duty, 1/9 Bias
- I Power Supply Voltage : 3.0V
- I LCD Operation Voltage : 9.0V
- I Display Contents : 128 x 64 Dots
- I Driver IC : IST3004-TX
- I RoHS Compliant

2. MECHANICAL SPECIFICATIONS

- I Module Size : 58.20 x 41.70 x 5.70 mm
- I Viewing Area : 50.00 x 25.00 mm
- I Active Area : 46.06 x 23.02 mm
- I Dot Size : 0.34 x 0.34 mm
- I Dot Gap : 0.02 mm

3. EXTERNAL DIMENSIONS

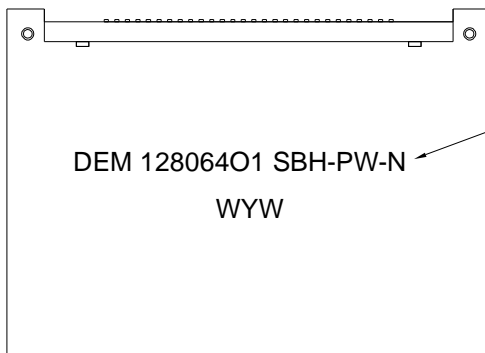
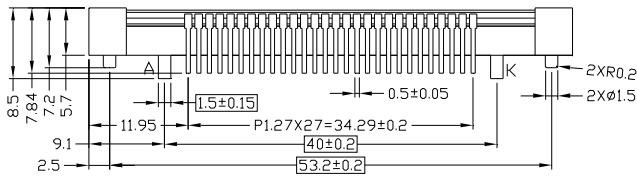
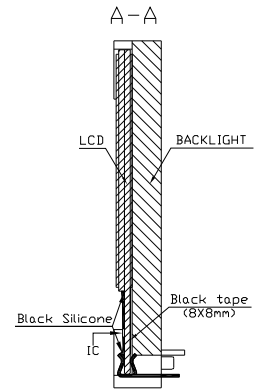
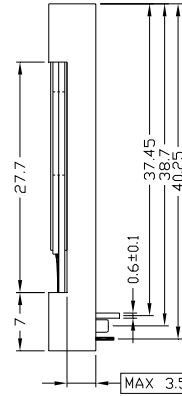
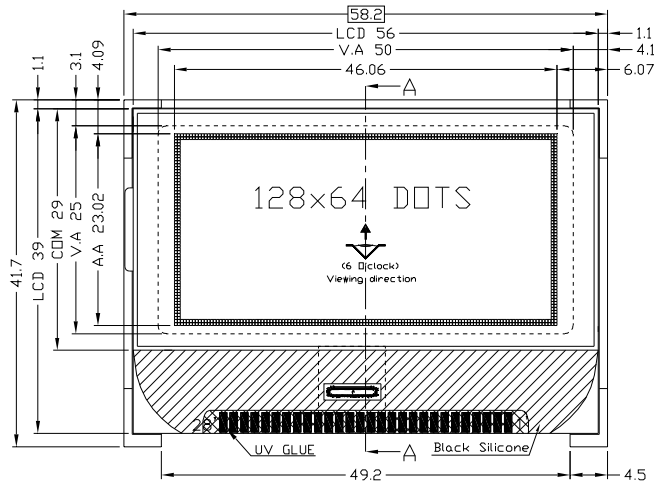

print the full part-number

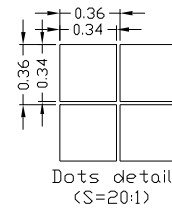

Remarks:

1. Unmarked tolerance is ± 0.3
2. All materials comply with RoHS
3. ...critical dimension.

4. BLOCK DIAGRAM

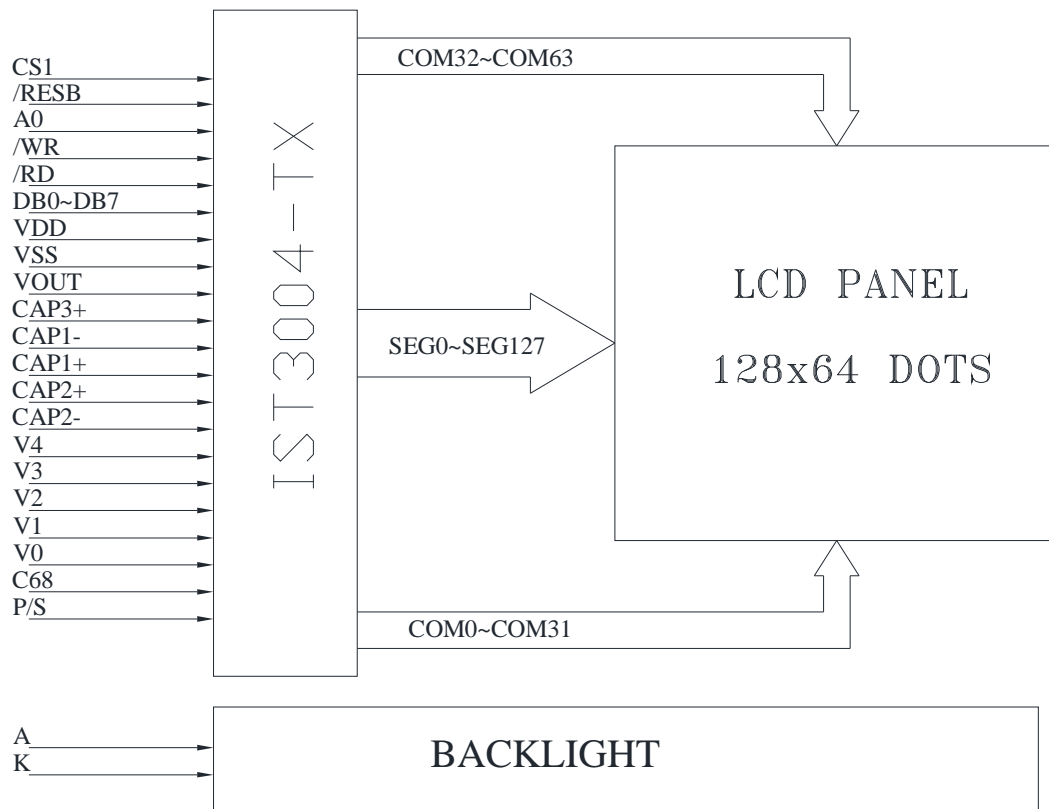

5. PIN ASSIGNMENT

PIN No.	Symbol	I/O	Description																					
1	CS1	I	Chip select input pins Data / instruction I/O is enabled only when CS1B when chip select is non-active, DB0 to DB7 may be high impedance																					
2	/RESB	I	Hardware Reset input pin When RESB is "L", initialization is executed.																					
3	A0	I	Register select input pin - A0 = "H" : DB0 to DB7 are display data - A0 = "L" : DB0 to DB7 are control data																					
4	/WR	I	Read / Write execution control pin																					
			<table border="1"> <thead> <tr> <th>C86</th> <th>MPU Type</th> <th>RW_WRB</th> <th>Description</th> </tr> </thead> <tbody> <tr> <td>H</td> <td>6800-series</td> <td>WR</td> <td>Read / Write control input pin - RW = "H" : read - RW = "L" : write</td> </tr> <tr> <td>L</td> <td>8080-series</td> <td>/WRB</td> <td>Write enable clock input pin The data on DB0 to DB7 are latched at the rising edge of the /WRB signal.</td> </tr> </tbody> </table>	C86	MPU Type	RW_WRB	Description	H	6800-series	WR	Read / Write control input pin - RW = "H" : read - RW = "L" : write	L	8080-series	/WRB	Write enable clock input pin The data on DB0 to DB7 are latched at the rising edge of the /WRB signal.									
			C86	MPU Type	RW_WRB	Description																		
H	6800-series	WR	Read / Write control input pin - RW = "H" : read - RW = "L" : write																					
L	8080-series	/WRB	Write enable clock input pin The data on DB0 to DB7 are latched at the rising edge of the /WRB signal.																					
5	/RD	I	When connected to 8080 series MPU, this pin is treated as the "/RD" signal of the 8080MPU and is LOW-active. The data bus is in an output status when this signal is "L". When connected to 6800 series MPU, this pin is treated as the "E" signal of the 6800 MPU and is HIGH-active. This is the enable clock input terminal of the 6800 Series MPU.																					
6~13	DB0~DB7	I/O	8-bit bi-directional data bus that is connected to the standard 8-bit microprocessor data bus. - DB0 to DB5 : high impedance - DB6 : serial input clock (SCL) - DB7 : serial input data (SDI) When chip select is not active, DB0 to DB7 may be high impedance.																					
14	VDD	Power Supply	Power Supply.																					
15	VSS	Power Supply	Ground																					
16	VOUT	I/O	Voltage converter output when the internal DC/DC converter is used If the panel loading too large for the internal DC/DC voltage converter to afford, user can disable internal Voltage Converter circuit & input external power through this pin to drive the remaining Power block (Voltage Regulator & Voltage Follower)																					
17	C3+	O	Capacitor for voltage converter.																					
18	C1-																							
19	C1+																							
20	C2+																							
21	C2-																							
22	V4	I/O	LCD driver supply voltages The voltage determined by LCD pixel is impedance-converted by an operational amplifier for application. Voltages should have the following relationship; $V0 \geq V1 \geq V2 \geq V3 \geq V4 \geq VSS$ When the internal power circuit is active, these voltages are generated as following as following table according to the state of LCD bias.																					
23	V3																							
24	V2																							
25	V1																							
26	V0																							
			<table border="1"> <thead> <tr> <th>LCD bias</th> <th>V1</th> <th>V2</th> <th>V3</th> <th>V4</th> </tr> </thead> <tbody> <tr> <td>1/9bias</td> <td>(8/9) xV0</td> <td>(7/9) xV0</td> <td>(2/9) xV0</td> <td>(1/9) xV0</td> </tr> </tbody> </table>	LCD bias	V1	V2	V3	V4	1/9bias	(8/9) xV0	(7/9) xV0	(2/9) xV0	(1/9) xV0											
LCD bias	V1	V2	V3	V4																				
1/9bias	(8/9) xV0	(7/9) xV0	(2/9) xV0	(1/9) xV0																				
27	C68	I	Microprocessor Interface Select input pin in parallel mode - C68 = "H" : 6800-series MPU interface - C68 = "L" : 8080-series MPU interface																					
28	P/S	I	Parallel / serial data input select input																					
			<table border="1"> <thead> <tr> <th>PS</th> <th>Interface Mode</th> <th>Chip Select</th> <th>Data / instruction</th> <th>Data</th> <th>Read / Write</th> <th>Serial clock</th> </tr> </thead> <tbody> <tr> <td>"H"</td> <td>Parallel</td> <td>CS1B</td> <td>A0</td> <td>DB0 to DB7</td> <td>E_RDB RW_WRB</td> <td>--</td> </tr> <tr> <td>"L"</td> <td>Serial</td> <td>CS1B</td> <td>A0</td> <td>SDI (DB7)</td> <td>Write only</td> <td>SCL (DB6)</td> </tr> </tbody> </table>	PS	Interface Mode	Chip Select	Data / instruction	Data	Read / Write	Serial clock	"H"	Parallel	CS1B	A0	DB0 to DB7	E_RDB RW_WRB	--	"L"	Serial	CS1B	A0	SDI (DB7)	Write only	SCL (DB6)
			PS	Interface Mode	Chip Select	Data / instruction	Data	Read / Write	Serial clock															
"H"	Parallel	CS1B	A0	DB0 to DB7	E_RDB RW_WRB	--																		
"L"	Serial	CS1B	A0	SDI (DB7)	Write only	SCL (DB6)																		
<NOTE> In serial mode, it is impossible to read data from the on-chip RAM. And DB0 to DB5 and E_RDB and RW_WRB must be fixed to either "H" or "L".																								

7. ABSOLUTE MAXIMUM RATINGS

Paramet		Symbol	Condition	Unit
Power Supply Voltage		V_D	-0.3 ~ 7.0	V
		V_0, V_{OUT}	-0.3~15.0	V
Power supply voltage (VDD standard)		V_1, V_2, V_3, V_4	-0.3 to V_0	V
Input voltage range		V_I	-0.3 to $V_{DD} + 0.3$	V
Operating temperature		TOP	-20~+70	°C
Storage temperature	Bare chip	TST	-30~+80	°C

8. ELECTRICAL CHARACTERISTICS

8-1. Electrical Characteristics (Ta=25°C, VDD=3.0V)

ITEM	SYMBOL	CONDITION	MIN.	TYP.	MAX.	UNIT	
Power Supply for LCM	VDD-VSS	---	2.7	3.0	3.3	V	
LCD Module Driving Voltage	V_0 -VSS	25°C	8.7	9.0	9.3	V	
Input Voltage	High	V_{IH}	H level	V_{SS}	---	0.2VDD	V
	Low	V_{IL}	L level	0.8VDD	---	VDD	V
Supply Current for LCM	IDD	VDD=3.0V	---	0.5	---	mA	
	Ie	---	---	---	---		
	ILED	VLED=3.2V	---	60	---		

8-2 Electro-Optical Characteristics

Item	Symbol	Measuring Condition	STD. Value				Unit
			°C	Min	Typ	Max	
Recommended Operating Voltage	VLCD	$\theta = 0$ $\Phi = 0$	25	—	9.0	—	V
Operating Voltage	V_{th}	$\theta = 0$ $\Phi = 0$	0	—	—	—	
			25	—	9.0	—	
			40	—	—	—	
	V_{sat}	$\theta = 0$ $\Phi = 0$	0	—	—	—	
			25	—	—	—	
			40	—	—	—	
Response Time	T_r	$\theta = 0$ $\Phi = 10$	0	—	—	—	
			25	—	218	268	
			40	—	—	—	
	T_f	$\theta = 0$ $\Phi = 10$	0	—	—	—	
			25	—	115	165	
			40	—	—	—	
Viewing Angle ($C_r \geq 2$)	θ	$\Phi = 0^\circ$	25	-10	10	40	Deg
	θ	$\Phi = 180^\circ$	25	30	10	—	
	θ	$\Phi = 90^\circ$	25	30	—	—	
	θ	$\Phi = 270^\circ$	25	—	—	—	
Current Consumption	ILCD	Hz = 64	25		82		uA

8-3 AC characteristics

System Bus Read/Write Characteristics 1 (For the 8080 Series MPU)

Read / Write Characteristics (8080-series MPU)

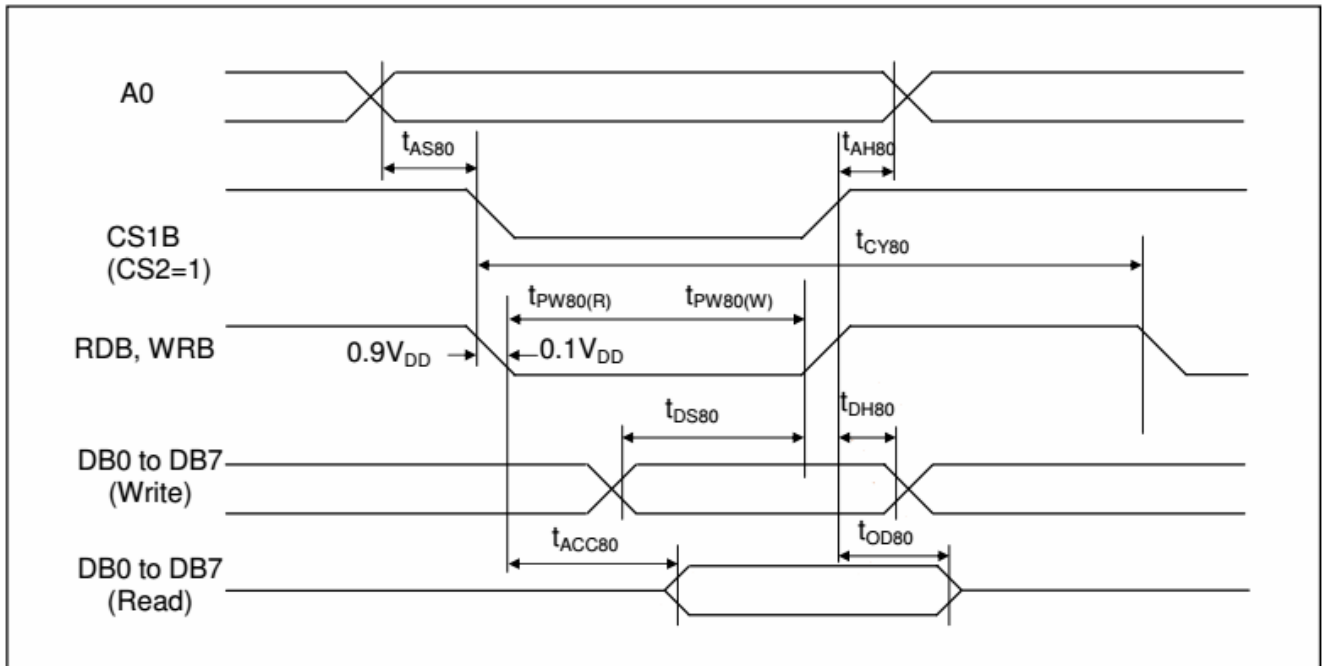

Item	Signal	Symbol	Min.	Typ.	Max.	Unit	Remark
Address setup time	A0	t_{AS80}	0	-	-	ns	
Address hold time		t_{AH80}	0	-	-	ns	
System cycle time		t_{CY80}	300	-	-	ns	
Pulse width (WRB)	RW_WRB	$t_{PW80(W)}$	150	-	-	ns	
Pulse width (RDB)	E_RDB	$t_{PW80(R)}$	150	-	-	ns	
Data setup time	DB7 to DB0	t_{DS80}	60	-	-	ns	
Data hold time		t_{DH80}	0	-	-	ns	
Read access time	DB0 to DB7	t_{ACC80}	140	-	-	ns	(No load)
Output disable time		t_{OD80}	-	-	10	ns	

System Bus Read/Write Characteristics 2 (For the 6800 Series MPU)

Read / Write Characteristics (6800-series Microprocessor)

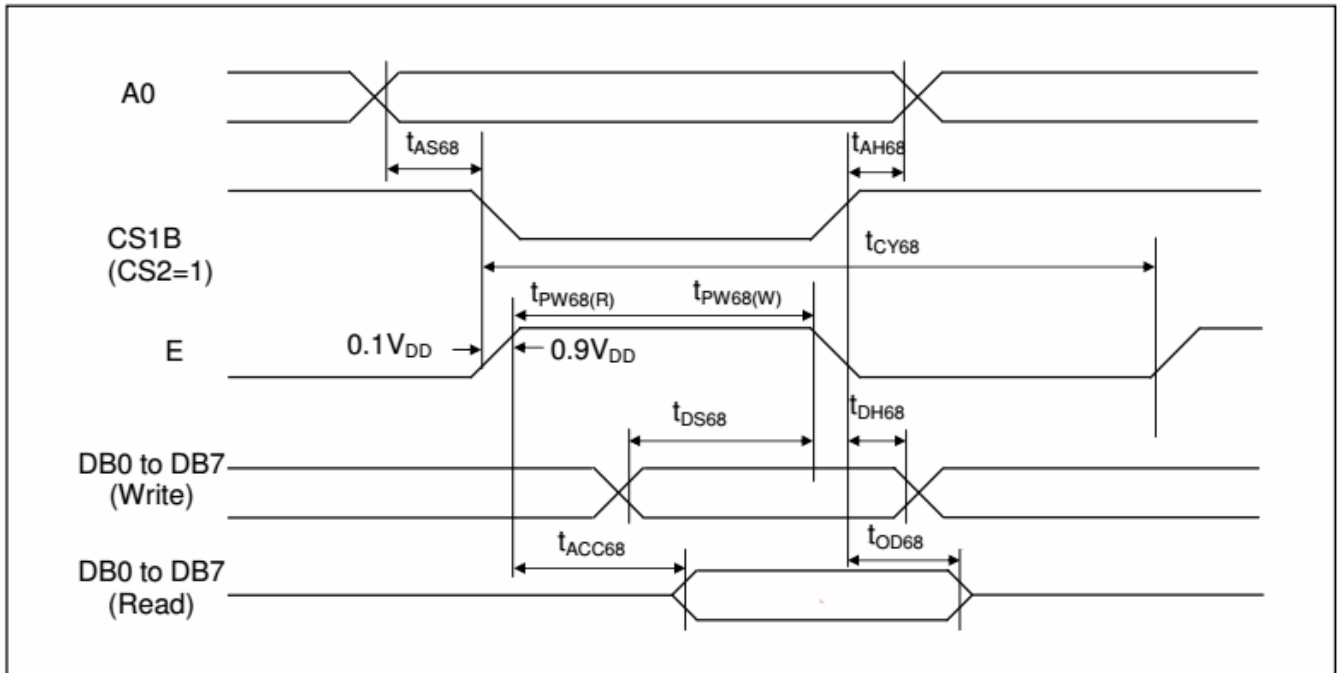

Item	Signal	Symbol	Min.	Typ.	Max.	Unit	Remark
Address setup time	A0		0	-	-	ns	
Address hold time	A0	tAH68	0	-	-	ns	
System cycle time		tCY68	300	-	-	ns	
Pulse width (E)	RW_WRB	tPW68(W)	150	-	-	ns	
Pulse width (E)	E_RDB	tPW68(R)	150	-	-	ns	
Data setup time	DB7 to DB0	tDS68	60	-	-	ns	
Data hold time		tDH68	0	-	-	ns	
Read access time	DB0 to DB0	tACC68	140	-	-	ns	(No load)
Output disable time		tOD68	-	-	10	ns	

8-4. Reset Characteristics

Reset Input Timing

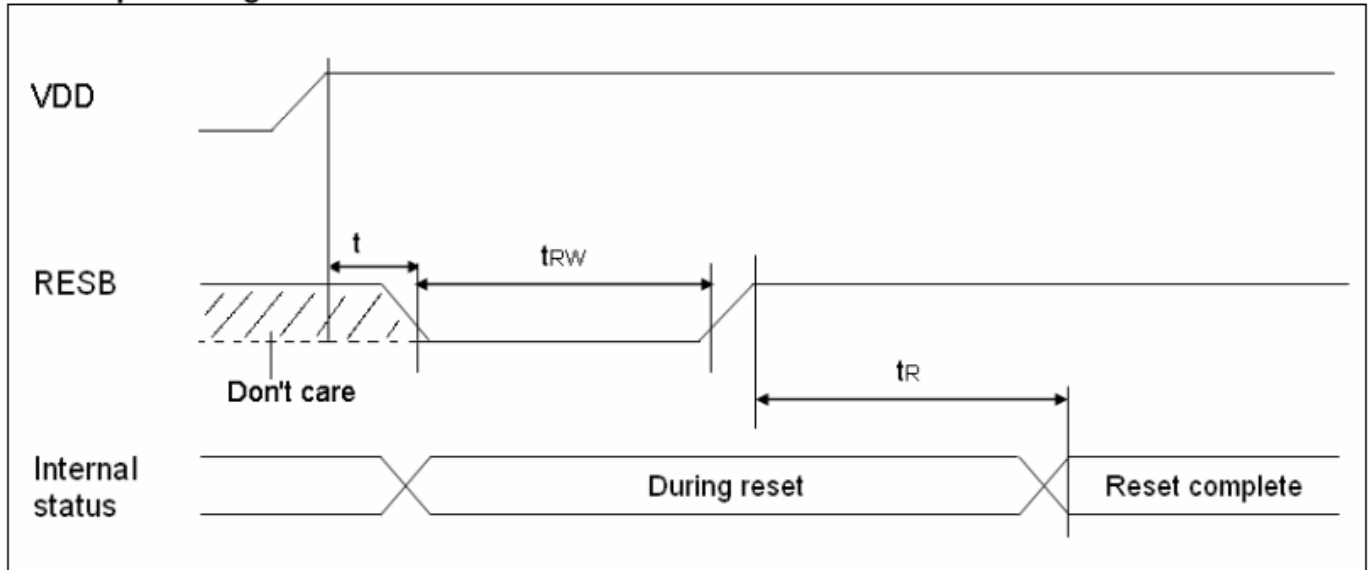

Item	Signal	Symbol	Min.	Typ.	Max.	Unit	Remark
Reset low pulse width	RESB	t_{RW}	2	-	-	US	
Reset time	-	t_R	-	-	2	US	
Reset time	RESB	t	0	-	-	US	

9. COMMAND TABLE

INSTRUCTION	A0	RW	DB7	DB6	DB5	DB4	DB3	DB2	DB1	DB0	Description
Display ON / OFF	0	0	1	0	1	0	1	1	1	DON	LCD display On/Off control DON = 0 : display OFF DON = 1 : display On
Display starting line	0	0	0	1	ST5	ST4	ST3	ST2	ST1	ST0	Specify the line address for the first COM output
page address	0	0	1	0	1	1	P3	P2	P1	P0	Set page address
Set column address MSB	0	0	0	0	0	1	Y7	Y6	Y5	Y4	Set column address MSB
Set column address LSB	0	0	0	0	0	0	Y3	Y2	Y1	Y0	Set column address LSB
Read status	0	1	BUSY	ADC	ON/OFF	RESB	0	0	0	0	Read the internal status
Write display data	1	0	Write data								Write data into Display RAM
Read display data	1	1	Read data								Read data from Display RAM
ADC select	0	0	1	0	1	0	0	0	0	ADC	SEG output direction select ADC = 0 : SEG0 → SEG131 ADC = 1 : SEG131 → SEG0
Reverse display ON / OFF	0	0	1	0	1	0	0	1	1	REV	Normal / Reverse display select REV = 0 : Reverse display off REV = 1 : Reverse display on
Entire display ON / OFF	0	0	1	0	1	0	0	1	0	EON	Entire display On/Off control EON = 0 : Entire display off EON = 1 : Entire display on
LCD bias select	0	0	1	0	1	0	0	0	1	BS	Select LCD bias
Set Read-modify-write (RMW)	0	0	1	1	1	0	0	0	0	0	Set Read-modify-write mode
Clear RMW	0	0	1	1	1	0	1	1	1	0	Clear Read-modify-write mode
S/W Reset	0	0	1	1	1	0	0	0	1	0	S/W Reset
SHL select	0	0	1	1	0	0	SHL	x	x	x	COM output direction select SHL = 0 : COM0 → COM63 SHL = 1 : COM63 → COM0
Power control	0	0	0	0	1	0	1	VC	VR	VF	Control power circuit operation
Regulator resistor select	0	0	0	0	1	0	0	R2	R1	R0	Select internal resistance ratio of the regulator resistor
Set reference voltage mode	0	0	1	0	0	0	0	0	0	1	Set reference voltage mode (double byte command)
Set reference voltage register	0	0	x	x	SV5	SV4	SV3	SV2	SV1	SV0	Set reference voltage register
Set static indicator mode	0	0	1	0	1	0	1	1	0	SM	Set static indicator mode (double byte command)
Set static indicator register	0	0	x	x	x	x	x	x	S1	S0	Set static indicator register
Power save	-	-	-	-	-	-	-	-	-	-	Compound Instruction of display OFF and entire display ON
NOP	0	0	1	1	1	0	0	0	1	1	No operation (dummy command)
Set Booster Ratio select mode	0	0	1	1	1	1	1	0	0	0	Set Booster ration select mode (double byte command)
Set Booster Ratio register	0	0	x	x	x	x	x	x	BT1	BT0	Set Booster ration BT[1:0] = 00 : x2, x3, x4 BT[1:0] = 01 : x5 BT[1:0] = 11 : x6 BT[1:0] = 10 : (don't use)
Test Instruction	0	0	1	0	0	0	1	0	0	0	Test command (don't use)

10. LCD ARTWORT

10-1. LCD ARTWORK

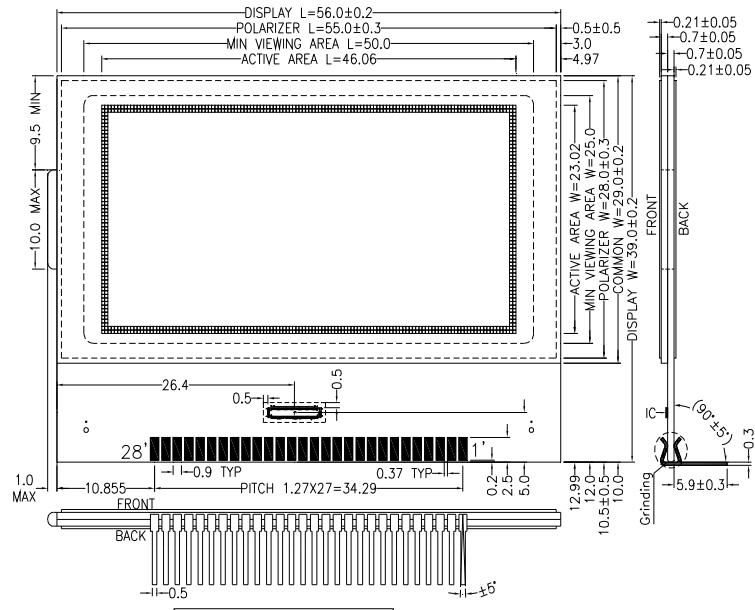

UNLESS OTHERWISE SPECIFIED
DIMENSIONS ARE IN MM
TOLERANCES: ±0.2MM

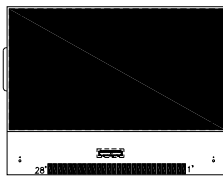

10-2. COMMON LAYOUT

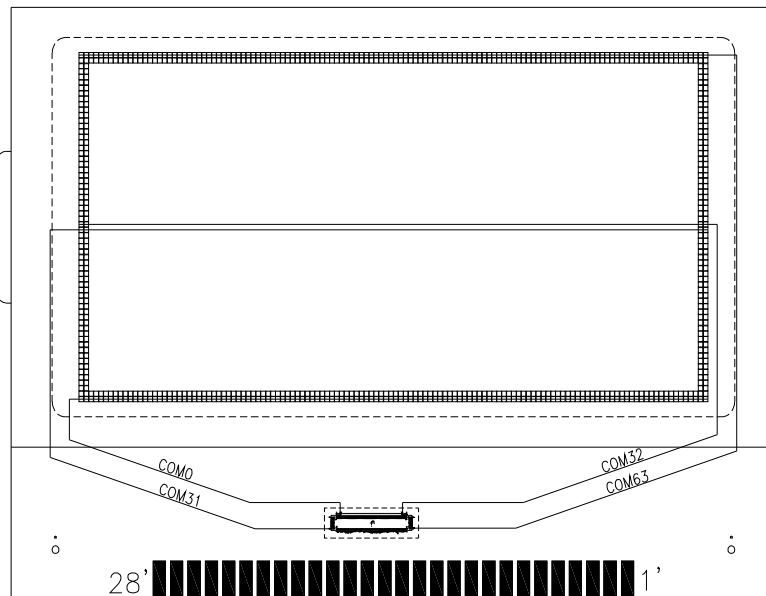

10-3. SEGMENT LAYOUT

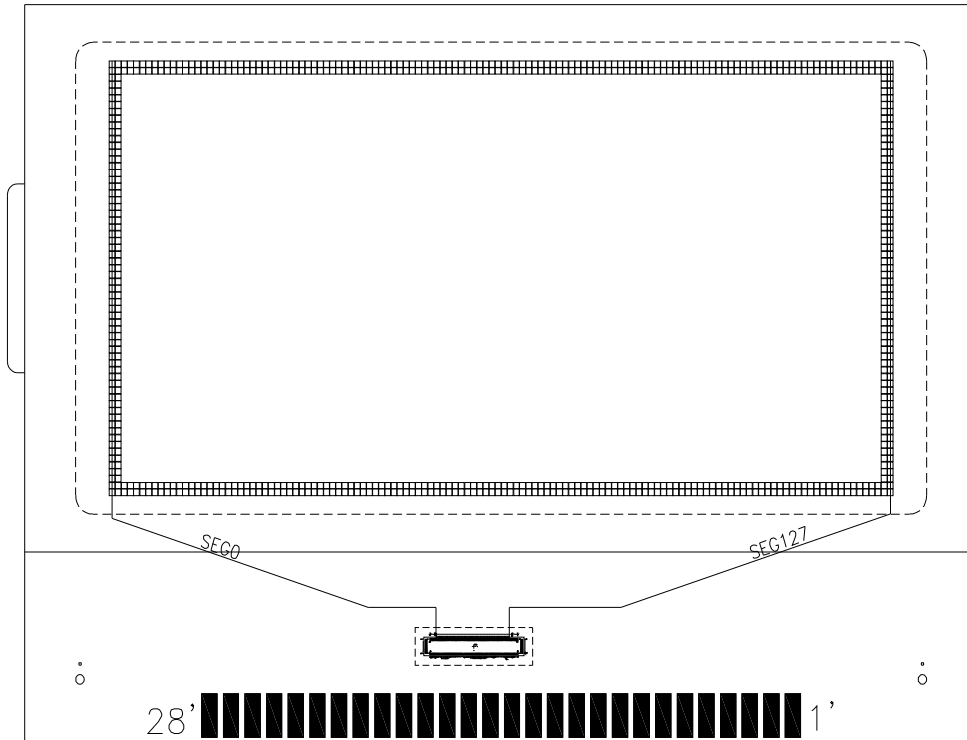

10-4. GRAPHIC DIMENSION & PAD CONFIGURATION

PAD NO.	PAD CONFIGURATION
1	COM63[R63(C0-C127)]
32	COM32[R32(C0-C127)]
33	SEG127[C127(R0-R63)]
160	SEG0[C0(R0-R63)]
161	COM0[R0(C0-C127)]
192	COM31[R31(C0-C127)]

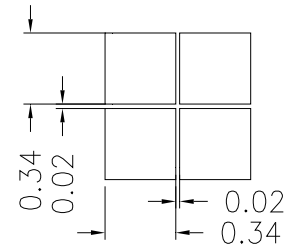

10-5. IC LAYOUT

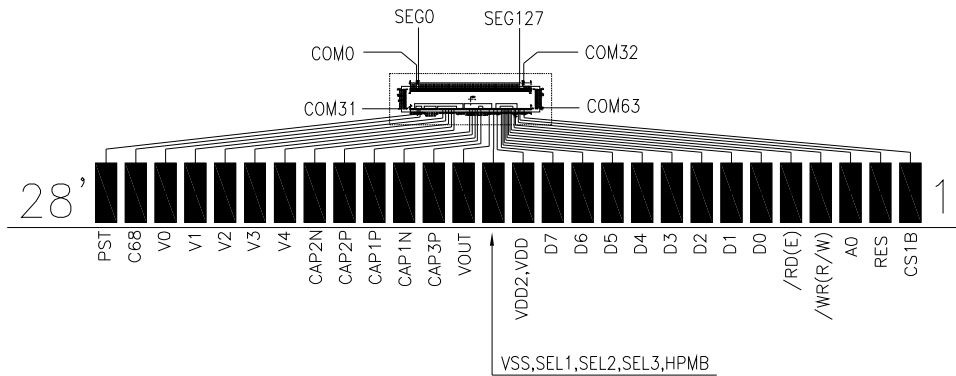

11. ACCEPT QUALITY LEVEL (AQL)

11.1 Inspection Plan: ANSI Z-1.4, Normal Inspection Level II, Single Sampling Plan

12. RELIABILITY TEST

Operating life time: 50000 hours (at room temperature without direct irradiation of sunlight)

Reliability characteristics shall meet following requirements.

Test Item	Test Condition
High Temperature Storage	+80°C x 96hrs
Low Temperature Storage	-30°C x 96hrs
High Temperature Operation	+70°C x 96hrs
Low Temperature Operation	-20°C x 96hrs
High Temperature, High Humidity	+60°C x 90%RH x 96hrs
Thermal Shock	-20°C x 30min → +25°C x 10s → +70°C x 30min 10Cycles
Vibration Test	Frequency x Swing x Time 40Hz x 4mm x 4hrs
Drop Test	Drop height x No. of drops 1.0m x 6drops

13. LCD MODULES HANDLING PRECAUTIONS

- n** Please remove the protection foil of polarizer before using.
- n** The display panel is made of glass. Do not subject it to a mechanical shock by dropping it from a high place, etc.
- n** If the display panel is damaged and the liquid crystal substance inside it leaks out, do not get any in your mouth. If the substance come into contact with your skin or clothes promptly wash it off using soap and water.
- n** Do not apply excessive force to the display surface or the adjoining areas since this may cause the color tone to vary.
- n** The polarizer covering the display surface of the LCD module is soft and easily scratched. Handle this polarize carefully.
- n** To prevent destruction of the elements by static electricity, be careful to maintain an optimum work environment.
 - Be sure to ground the body when handling the LCD module.
 - Tools required for assembly, such as soldering irons, must be properly grounded.
 - To reduce the amount of static electricity generated, do not conduct assembly and other work under dry conditions.
 - The LCD module is coated with a film to protect the display surface. Exercise care when peeling off this protective film since static electricity may be generated.
- n** Storage precautions
 - When storing the LCD modules, avoid exposure to direct sunlight or to the light of fluorescent lamps. Keep the modules in bags designed to prevent static electricity charging under low temperature / normal humidity conditions (avoid high temperature / high humidity and low temperatures below 0°C).Whenever possible, the LCD modules should be stored in the same conditions in which they were shipped from our company.

14. OTHERS

- n** Liquid crystals solidify at low temperature (below the storage temperature range) leading to defective orientation of liquid crystal or the generation of air bubbles (black or white). Air bubbles may also be generated if the module is subjected to a strong shock at a low temperature.
- n** If the LCD modules have been operating for a long time showing the same display patterns may remain on the screen as ghost images and a slight contrast irregularity may also appear. Abnormal operating status can be resumed to be normal condition by suspending use for some time. It should be noted that this phenomena does not adversely affect performance reliability.
- n** To minimize the performance degradation of the LCD modules resulting from caused by static electricity, etc. exercise care to avoid holding the following sections when handling the modules:
 - Exposed area of the printed circuit board
 - Terminal electrode sections