

Display Elektronik GmbH

DATA SHEET

*LCD-MODULE*

**DEM 12201 SBH-PW-N**

Product Specification

Ver.:9

27.11.2024

## Revision History

<b>VERSION</b>	<b>DATE</b>	<b>REVISED PAGE NO.</b>	<b>Note</b>
0	22.07.2009		First issue
1	10.06.2014		Modify ST7066U IC information
2	17.07.2015		Modify Backlight Information
3	25.02.2016		Remove IC information
4	19.10.2017		Modify Precautions in use of LCD Modules & Static electricity test
5	29.09.2019		Modify Backlight Information
6	30.12.2019		Modify Material List of Components for RoHs
7	25.09.2020		Modify Precautions in use of LCD Modules
8	15.03.2013		Add Interface
9	27.11.2024		Modify Backlight Information(Note) Modify the recommended soldering temperature

# Contents

- 1.General Specification
- 2.Interface Pin Function
- 3.Contour Drawing &Block Diagram
- 4.Character Generator ROM Pattern
- 5.Optical Characteristics
- 6.Absolute Maximum Ratings
- 7.Electrical Characteristics
- 8.Backlight Information
- 9.Reliability
- 10.Inspection specification
- 11.Precautions in use of LCD Modules
- 12.Material List of Components for RoHs
- 13.Recommendable Storage

## **1.General Specification**

The Features is described as follow:

- n Module dimension: 55.7 x 32.0 x 14.5 (max.) mm
- n View area: 46.0 x 14.5 mm
- n Active area: 37.85 x 11.7 mm
- n Number of Characters: 12 characters x 2Lines
- n Dot size: 0.45 x 0.60 mm
- n Dot pitch: 0.55 x 0.70 mm
- n Character size: 2.65 x 5.50 mm
- n Character pitch: 3.20 x 6.20 mm
- n LCD type: STN Negative, Blue Transmissive
- n Duty: 1/16
- n View direction: 6 o'clock
- n Backlight Type: LED, White
- n IC:ST7066U
- n Interface:68 series

## 2.Interface Pin Function

Pin No.	Symbol	Level	Description
1	V <sub>SS</sub>	0V	Ground
2	V <sub>DD</sub>	5.0V	Supply Voltage for logic
3	VO	(Variable)	Operating voltage for LCD
4	RS	H/L	H: DATA, L: Instruction code
5	R/W	H/L	H: Read L: Write
6	E	H,H→L	Chip enable signal
7	DB0	H/L	Data bus line
8	DB1	H/L	Data bus line
9	DB2	H/L	Data bus line
10	DB3	H/L	Data bus line
11	DB4	H/L	Data bus line
12	DB5	H/L	Data bus line
13	DB6	H/L	Data bus line
14	DB7	H/L	Data bus line
15	A	-	LED+

### 3. Contour Drawing & Block Diagram

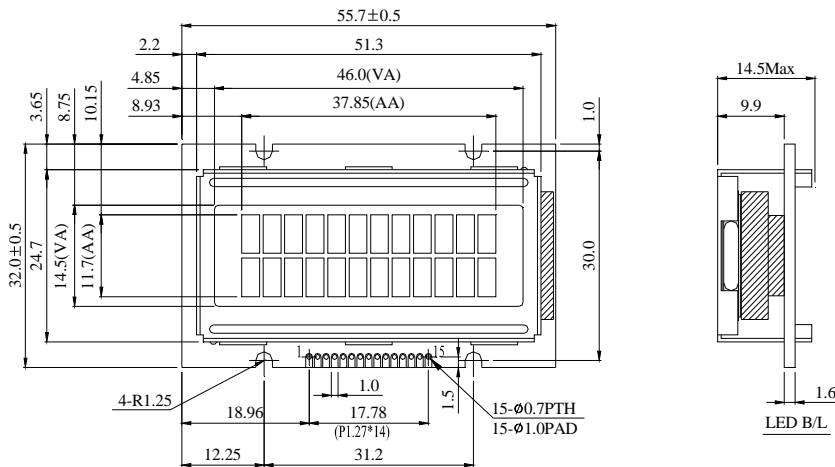

PIN NO.	SYMBOL
1	Vss
2	Vdd
3	Vo
4	RS
5	R/W
6	E
7	DB0
8	DB1
9	DB2
10	DB3
11	DB4
12	DB5
13	DB6
14	DB7
15	A

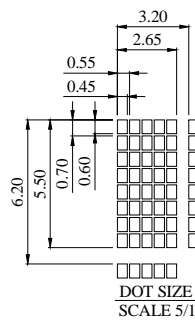

The non-specified tolerance of dimension is ±0.3mm.

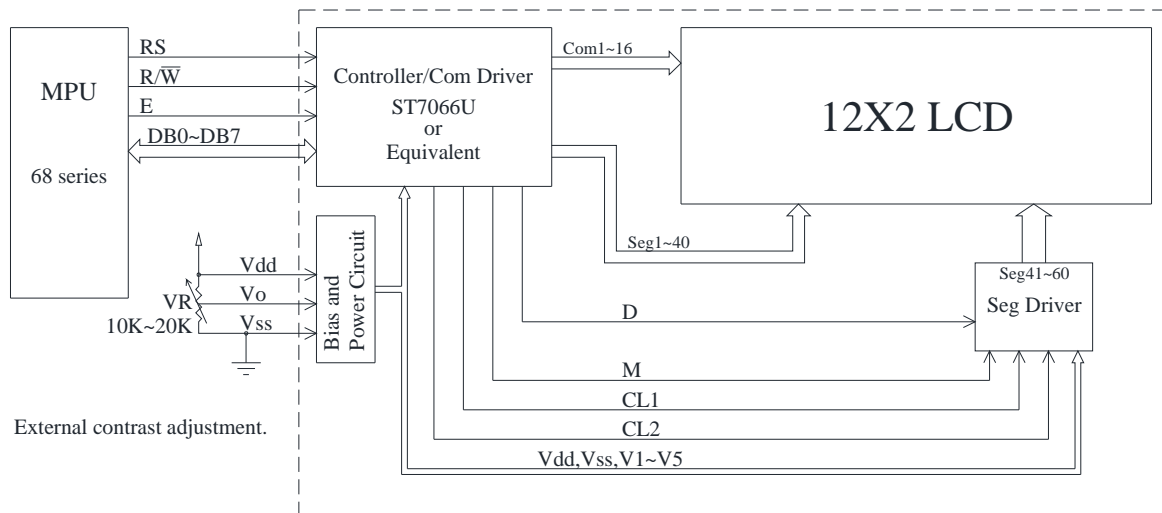

Character located	1	2	3	4	5	6	7	8	9	10	11	12
DDRAM address	00	01	02	03	04	05	06	07	08	09	0A	0B
DDRAM address	40	41	42	43	44	45	46	47	48	49	4A	4B

# 4.Character Generator ROM Pattern

Table.2

Upper 4 bit Lower 4 bit	LLLL	LLLH	LLHL	LLHH	LHLL	LHLH	LHHL	LHHH	HLLL	HLLH	HLHL	HLHH	HHLL	HHLH	HHHL	HHHH
LLLL	CG RAM (1)			0	1	2	3	4				5	6	7	8	9
LLLH	(2)		!	!	!	!	!	!			!	!	!	!	!	!
LLHL	(3)		"	"	"	"	"	"			"	"	"	"	"	"
LLHH	(4)		#	#	#	#	#	#			#	#	#	#	#	#
LHLL	(5)		\$	\$	\$	\$	\$	\$			\$	\$	\$	\$	\$	\$
LHLH	(6)		%	%	%	%	%	%			%	%	%	%	%	%
LHHL	(7)		&	&	&	&	&	&			&	&	&	&	&	&
LHHH	(8)		'	'	'	'	'	'			'	'	'	'	'	'
HLLL	(1)		(	(	(	(	(	(			(	(	(	(	(	(
HLLH	(2)		)	)	)	)	)	)			)	)	)	)	)	)
HLHL	(3)		*	*	*	*	*	*			*	*	*	*	*	*
HLHH	(4)		+	+	+	+	+	+			+	+	+	+	+	+
HHLL	(5)		,	,	,	,	,	,			,	,	,	,	,	,
HHLH	(6)		-	-	-	-	-	-			-	-	-	-	-	-
HHHL	(7)		.	.	.	.	.	.			.	.	.	.	.	.
HHHH	(8)		/	/	/	/	/	/			/	/	/	/	/	/

### 5.Optical Characteristics

Item	Symbol	Condition	Min	Typ	Max	Unit
View Angle	$\theta$	CR□2	0	-	20	$\psi= 180^\circ$
	$\theta$	CR□2	0	-	40	$\psi= 0^\circ$
	$\theta$	CR□2	0	-	30	$\psi= 90^\circ$
	$\theta$	CR□2	0	-	30	$\psi= 270^\circ$
Contrast Ratio	CR	-	-	3	-	-
Response Time	T rise	-	-	150	200	ms
	T fall	-	-	150	200	ms

**Definition of Operation Voltage (Vop)**

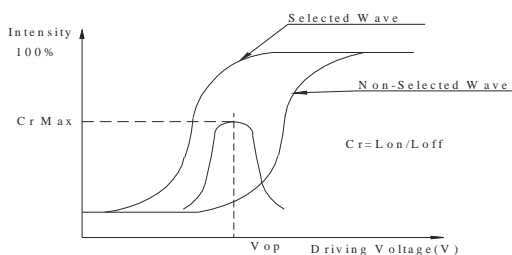
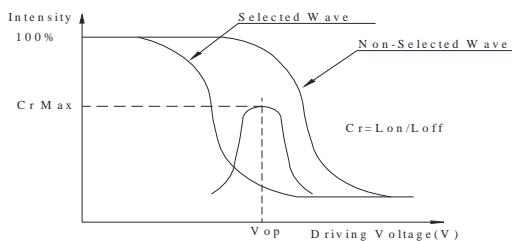

**Definition of Response Time (Tr , Tf)**

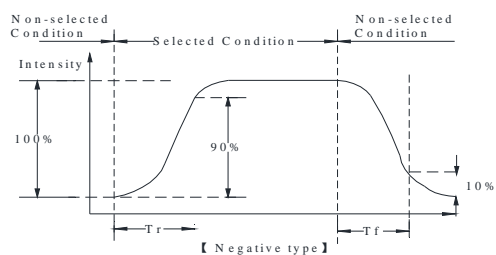
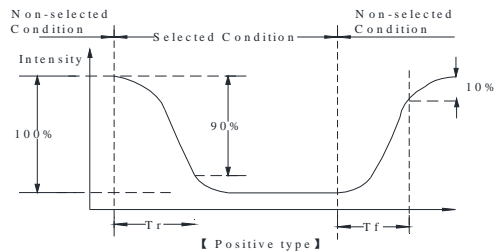

**Conditions :**

Operating Voltage : Vop

Viewing Angle( $\theta$  ,  $\phi$ ) :  $0^\circ$  ,  $0^\circ$

Frame Frequency : 64 HZ Driving Waveform : 1/N duty , 1/a bias



**Definition of viewing angle(CR□2)**

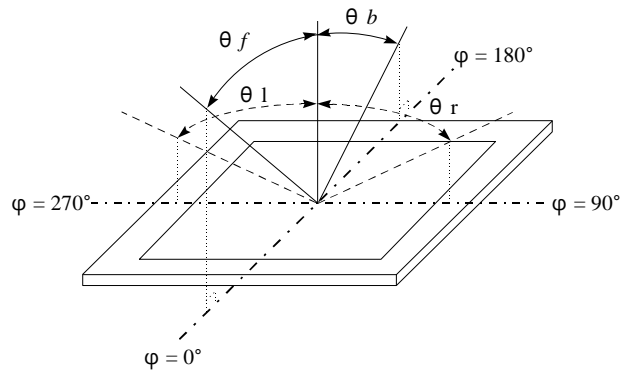

## 6. Absolute Maximum Ratings

Item	Symbol	Min	Typ	Max	Unit
Operating Temperature	T <sub>OP</sub>	-20	-	+70	°C
Storage Temperature	T <sub>ST</sub>	-30	-	+80	°C
Input Voltage	V <sub>I</sub>	V <sub>SS</sub>	-	V <sub>DD</sub>	V
Supply Voltage For Logic	V <sub>DD</sub> -V <sub>SS</sub>	-0.3	-	7	V
Supply Voltage For LCD	V <sub>DD</sub> -V <sub>o</sub>	-0.3	-	13	V

## 7. Electrical Characteristics

Item	Symbol	Condition	Min	Typ	Max	Unit
Supply Voltage For Logic	$V_{DD-VSS}$	-	4.5	5.0	5.5	V
Supply Voltage For LCD * Note	$V_{DD-V_0}$	$T_a=-20^{\circ}\text{C}$	-	-	5.7	V
		$T_a=25^{\circ}\text{C}$	4.1	4.2	4.3	V
		$T_a=70^{\circ}\text{C}$	3.5	-	-	V
Input High Volt.	$V_{IH}$	-	$0.7 V_{DD}$	-	$V_{DD}$	V
Input Low Volt.	$V_{IL}$	-	$V_{SS}$	-	0.6	V
Output High Volt.	$V_{OH}$	-	3.9	-	$V_{DD}$	V
Output Low Volt.	$V_{OL}$	-	0	-	0.4	V
Supply Current	$I_{DD}$	$V_{DD}=5.0\text{V}$	-	1.2	-	mA

Note: Please design the VOP adjustment circuit on customer's main board

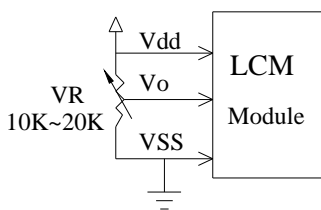

## 8.Backlight Information

### Specification

PARAMETER	SYMBOL	MIN	TYP	MAX	UNIT	TEST CONDITION
Supply Current	I <sub>LED</sub>	10	32	40	mA	V=3.5V(Note 1)
Supply Voltage	V	3.4	3.5	3.6	V	-
Reverse Voltage	V <sub>R</sub>	-	-	5	V	-
Color coordinate	X	0.245	0.275	0.305	-	-
	Y	0.265	0.295	0.325	-	-
Luminance (Without LCD)	I <sub>V</sub>	840	1050	-	CD/M <sup>2</sup>	I <sub>LED</sub> =32mA
LED Life Time (For Reference only)	-	-	50K	-	Hr.	I <sub>LED</sub> =32mA 25°C,50-60%RH, (Note 2)
Color	White					

**Note:** A backlight driven by voltage will keep the drive current under the safe area (current between minimum and maximum).

If the B/L LED is driven by current only, the drive voltage cannot be considered as a reference value.

**Note 1:** Supply current minimum value is only for reference since LED brightness efficiency keeps enhancing. Current consumption becomes less and less to achieve the same luminance.

**Note 2:** 50K hours is only an estimate for reference.

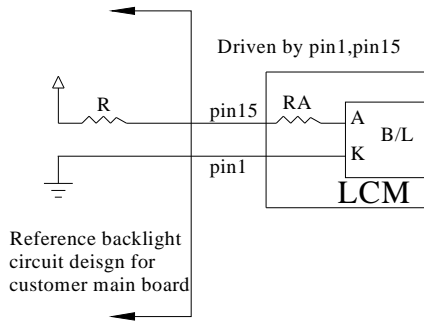

## 9. Reliability

### Content of Reliability Test (Wide temperature, -20°C~70°C)

Environmental Test			
Test Item	Content of Test	Test Condition	Note
High Temperature storage	Endurance test applying the high storage temperature for a long time.	80°C 200hrs	2
Low Temperature storage	Endurance test applying the low storage temperature for a long time.	-30°C 200hrs	1,2
High Temperature Operation	Endurance test applying the electric stress (Voltage & Current) and the thermal stress to the element for a long time.	70°C 200hrs	—
Low Temperature Operation	Endurance test applying the electric stress under low temperature for a long time.	-20°C 200hrs	1
High Temperature/ Humidity storage	The module should be allowed to stand at 60°C, 90%RH max For 96hrs under no-load condition excluding the polarizer, Then taking it out and drying it at normal temperature.	60°C, 90%RH 96hrs	1,2
Thermal shock resistance	The sample should be allowed stand the following 10 cycles of operation -20°C    25°C    70°C  30min    5min    30min 1 cycle	-20°C / 70°C 10 cycles	—
Vibration test	Endurance test applying the vibration during transportation and using.	Total fixed amplitude : 1.5mm Vibration Frequency : 10~55Hz One cycle 60 seconds to 3 directions of X,Y,Z for Each 15 minutes	3
Static electricity test	Endurance test applying the electric stress to the terminal.	VS=±600V(contact), ±800v(air), RS=330Ω CS=150pF 10 times	—

**Note1: No dew condensation to be observed.**

**Note2: The function test shall be conducted after 4 hours storage at the normal Temperature and humidity after remove from the test chamber.**

**Note3: The packing have to including into the vibration testing.**

### 10. Inspection specification

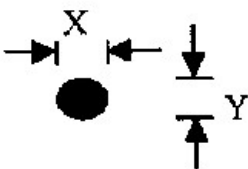
NO	Item	Criterion	AQL										
01	Electrical Testing	1.1 Missing vertical, horizontal segment, segment contrast defect. 1.2 Missing character , dot or icon. 1.3 Display malfunction. 1.4 No function or no display. 1.5 Current consumption exceeds product specifications. 1.6 LCD viewing angle defect. 1.7 Mixed product types. 1.8 Contrast defect.	0.65										
02	Black or white spots on LCD (display only)	2.1 White and black spots on display $\leq 0.25\text{mm}$ , no more than three white or black spots present. 2.2 Densely spaced: No more than two spots or lines within 3mm	2.5										
03	LCD black spots, white spots, contamination (non-display)	3.1 Round type : As following drawing $\Phi = (x + y) / 2$ <table border="1" style="margin-left: 20px;"> <thead> <tr> <th>SIZE</th> <th>Acceptable Q TY</th> </tr> </thead> <tbody> <tr> <td><math>\Phi \leq 0.10</math></td> <td>Accept no dense</td> </tr> <tr> <td><math>0.10 &lt; \Phi \leq 0.20</math></td> <td>2</td> </tr> <tr> <td><math>0.20 &lt; \Phi \leq 0.25</math></td> <td>1</td> </tr> <tr> <td><math>0.25 &lt; \Phi</math></td> <td>0</td> </tr> </tbody> </table> 	SIZE	Acceptable Q TY	$\Phi \leq 0.10$	Accept no dense	$0.10 < \Phi \leq 0.20$	2	$0.20 < \Phi \leq 0.25$	1	$0.25 < \Phi$	0	2.5
		SIZE	Acceptable Q TY										
$\Phi \leq 0.10$	Accept no dense												
$0.10 < \Phi \leq 0.20$	2												
$0.20 < \Phi \leq 0.25$	1												
$0.25 < \Phi$	0												
3.2 Line type : (As following drawing) <table border="1" style="margin-left: 20px;"> <thead> <tr> <th>Length</th> <th>Width</th> <th>Acceptable Q TY</th> </tr> </thead> <tbody> <tr> <td>---</td> <td><math>W \leq 0.02</math></td> <td>Accept no dense</td> </tr> <tr> <td><math>L \leq 3.0</math></td> <td><math>0.02 &lt; W \leq 0.03</math></td> <td rowspan="2">2</td> </tr> <tr> <td><math>L \leq 2.5</math></td> <td><math>0.03 &lt; W \leq 0.05</math></td> </tr> </tbody> </table>	Length	Width	Acceptable Q TY	---	$W \leq 0.02$	Accept no dense	$L \leq 3.0$	$0.02 < W \leq 0.03$	2	$L \leq 2.5$	$0.03 < W \leq 0.05$	2.5	
Length	Width	Acceptable Q TY											
---	$W \leq 0.02$	Accept no dense											
$L \leq 3.0$	$0.02 < W \leq 0.03$	2											
$L \leq 2.5$	$0.03 < W \leq 0.05$												

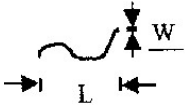
			---	$0.05 < W$	As round type												
04	Polarizer bubbles	If bubbles are visible, judge using black spot specifications, not easy to find, must check in specify direction.	<table border="1"> <thead> <tr> <th>Size <math>\Phi</math></th> <th>Acceptable Q TY</th> </tr> </thead> <tbody> <tr> <td><math>\Phi \leq 0.20</math></td> <td>Accept no dense</td> </tr> <tr> <td><math>0.20 &lt; \Phi \leq 0.50</math></td> <td>3</td> </tr> <tr> <td><math>0.50 &lt; \Phi \leq 1.00</math></td> <td>2</td> </tr> <tr> <td><math>1.00 &lt; \Phi</math></td> <td>0</td> </tr> <tr> <td>Total Q TY</td> <td>3</td> </tr> </tbody> </table>		Size $\Phi$	Acceptable Q TY	$\Phi \leq 0.20$	Accept no dense	$0.20 < \Phi \leq 0.50$	3	$0.50 < \Phi \leq 1.00$	2	$1.00 < \Phi$	0	Total Q TY	3	2.5
Size $\Phi$	Acceptable Q TY																
$\Phi \leq 0.20$	Accept no dense																
$0.20 < \Phi \leq 0.50$	3																
$0.50 < \Phi \leq 1.00$	2																
$1.00 < \Phi$	0																
Total Q TY	3																

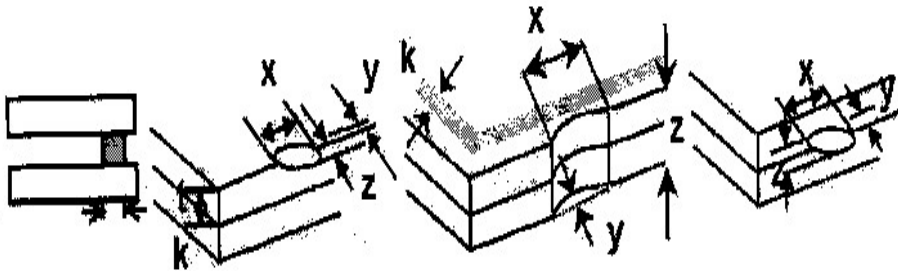
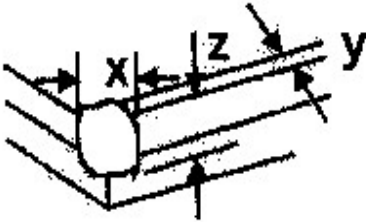

NO	Item	Criterion	AQL																		
05	Scratches	Follow NO.3 LCD black spots, white spots, contamination																			
06	Chipped glass	<p>Symbols Define:                      x: Chip length      y: Chip width      z: Chip thickness                      k: Seal width      t: Glass thickness      a: LCD side length                      L: Electrode pad length:</p> <p>6.1 General glass chip :                      6.1.1 Chip on panel surface and crack between panels:</p>  <table border="1" data-bbox="456 954 1369 1205"> <thead> <tr> <th>z: Chip thickness</th> <th>y: Chip width</th> <th>x: Chip length</th> </tr> </thead> <tbody> <tr> <td><math>z \leq 1/2t</math></td> <td>Not over viewing area</td> <td><math>x \leq 1/8a</math></td> </tr> <tr> <td><math>1/2t &lt; z \leq 2t</math></td> <td>Not exceed 1/3k</td> <td><math>x \leq 1/8a</math></td> </tr> </tbody> </table> <p>⊙ If there are 2 or more chips, x is total length of each chip.</p> <p>6.1.2 Corner crack:</p>  <table border="1" data-bbox="456 1682 1369 1933"> <thead> <tr> <th>z: Chip thickness</th> <th>y: Chip width</th> <th>x: Chip length</th> </tr> </thead> <tbody> <tr> <td><math>z \leq 1/2t</math></td> <td>Not over viewing area</td> <td><math>x \leq 1/8a</math></td> </tr> <tr> <td><math>1/2t &lt; z \leq 2t</math></td> <td>Not exceed 1/3k</td> <td><math>x \leq 1/8a</math></td> </tr> </tbody> </table> <p>⊙ If there are 2 or more chips, x is the total length of each chip.</p>	z: Chip thickness	y: Chip width	x: Chip length	$z \leq 1/2t$	Not over viewing area	$x \leq 1/8a$	$1/2t < z \leq 2t$	Not exceed 1/3k	$x \leq 1/8a$	z: Chip thickness	y: Chip width	x: Chip length	$z \leq 1/2t$	Not over viewing area	$x \leq 1/8a$	$1/2t < z \leq 2t$	Not exceed 1/3k	$x \leq 1/8a$	2.5
z: Chip thickness	y: Chip width	x: Chip length																			
$z \leq 1/2t$	Not over viewing area	$x \leq 1/8a$																			
$1/2t < z \leq 2t$	Not exceed 1/3k	$x \leq 1/8a$																			
z: Chip thickness	y: Chip width	x: Chip length																			
$z \leq 1/2t$	Not over viewing area	$x \leq 1/8a$																			
$1/2t < z \leq 2t$	Not exceed 1/3k	$x \leq 1/8a$																			

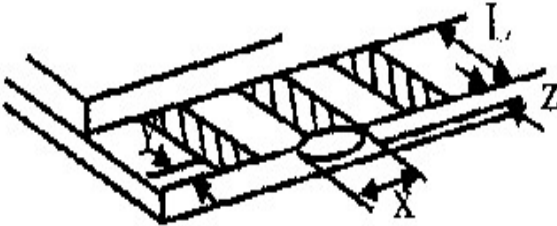
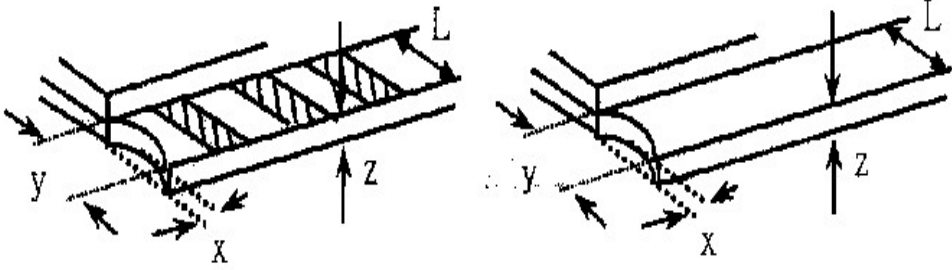
NO	Item	Criterion	AQL						
06	Glass crack	<p>Symbols :</p> <p>x: Chip length      y: Chip width      z: Chip thickness</p> <p>k: Seal width      t: Glass thickness      a: LCD side length</p> <p>L: Electrode pad length</p> <p>6.2 Protrusion over terminal :</p> <p>6.2.1 Chip on electrode pad :</p> 	2.5						
		<table border="1"> <thead> <tr> <th data-bbox="379 840 683 884">y: Chip width</th> <th data-bbox="683 840 994 884">x: Chip length</th> <th data-bbox="994 840 1297 884">z: Chip thickness</th> </tr> </thead> <tbody> <tr> <td data-bbox="379 884 683 969"><math>y \leq 0.5\text{mm}</math></td> <td data-bbox="683 884 994 969"><math>x \leq 1/8a</math></td> <td data-bbox="994 884 1297 969"><math>0 &lt; z \leq t</math></td> </tr> </tbody> </table>		y: Chip width	x: Chip length	z: Chip thickness	$y \leq 0.5\text{mm}$	$x \leq 1/8a$	$0 < z \leq t$
		y: Chip width		x: Chip length	z: Chip thickness				
		$y \leq 0.5\text{mm}$		$x \leq 1/8a$	$0 < z \leq t$				
<p>6.2.2 Non-conductive portion:</p> 									
<table border="1"> <thead> <tr> <th data-bbox="451 1373 738 1417">y: Chip width</th> <th data-bbox="738 1373 1026 1417">x: Chip length</th> <th data-bbox="1026 1373 1281 1417">z: Chip thickness</th> </tr> </thead> <tbody> <tr> <td data-bbox="451 1417 738 1518"><math>y \leq L</math></td> <td data-bbox="738 1417 1026 1518"><math>x \leq 1/8a</math></td> <td data-bbox="1026 1417 1281 1518"><math>0 &lt; z \leq t</math></td> </tr> </tbody> </table> <p>⊙If the chipped area touches the ITO terminal, over 2/3 of the ITO must remain and be inspected according to electrode terminal specifications.</p> <p>⊙If the product will be heat sealed by the customer, the alignment mark not be damaged.</p>	y: Chip width	x: Chip length	z: Chip thickness	$y \leq L$	$x \leq 1/8a$	$0 < z \leq t$			
y: Chip width	x: Chip length	z: Chip thickness							
$y \leq L$	$x \leq 1/8a$	$0 < z \leq t$							
		<p>6.2.3 Substrate protuberance and internal crack.</p> <table border="1"> <thead> <tr> <th data-bbox="786 1921 1074 1966">y: width</th> <th data-bbox="1074 1921 1353 1966">x: length</th> </tr> </thead> <tbody> <tr> <td data-bbox="786 1966 1074 2060"><math>y \leq 1/3L</math></td> <td data-bbox="1074 1966 1353 2060"><math>x \leq a</math></td> </tr> </tbody> </table>	y: width	x: length	$y \leq 1/3L$	$x \leq a$			
y: width	x: length								
$y \leq 1/3L$	$x \leq a$								

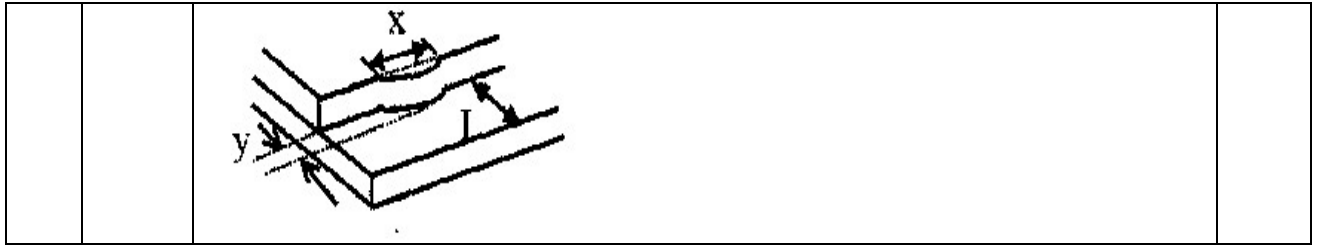

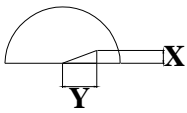
NO	Item	Criterion	AQL
07	Cracked glass	The LCD with extensive crack is not acceptable.	2.5
08	Backlight elements	8.1 Illumination source flickers when lit. 8.2 Spots or scratched that appear when lit must be judged. Using LCD spot, lines and contamination standards. 8.3 Backlight doesn't light or color wrong.	0.65 2.5 0.65
09	Bezel	9.1 Bezel may not have rust, be deformed or have fingerprints, stains or other contamination. 9.2 Bezel must comply with job specifications.	2.5 0.65
10	PCB、COB	10.1 COB seal may not have pinholes larger than 0.2mm or contamination. 10.2 COB seal surface may not have pinholes through to the IC. 10.3 The height of the COB should not exceed the height indicated in the assembly diagram. 10.4 There may not be more than 2mm of sealant outside the seal area on the PCB. And there should be no more than three places. 10.5 No oxidation or contamination PCB terminals. 10.6 Parts on PCB must be the same as on the production characteristic chart. There should be no wrong parts, missing parts or excess parts. 10.7 The jumper on the PCB should conform to the product characteristic chart. 10.8 If solder gets on bezel tab pads, LED pad, zebra pad or screw hold pad, make sure it is smoothed down. 10.9 The Scraping testing standard for Copper Coating of PCB  $X * Y \leq 2\text{mm}^2$	2.5 2.5 0.65 2.5 2.5 0.65 0.65 2.5 2.5
11	Soldering	11.1 No un-melted solder paste may be present on the PCB. 11.2 No cold solder joints, missing solder connections, oxidation or icicle. 11.3 No residue or solder balls on PCB. 11.4 No short circuits in components on PCB.	2.5 2.5 2.5 0.65

NO	Item	Criterion	AQL
12	General appearance	12.1 No oxidation, contamination, curves or, bends on interface Pin (OLB) of TCP.	2.5
		12.2 No cracks on interface pin (OLB) of TCP.	0.65
		12.3 No contamination, solder residue or solder balls on product.	2.5
		12.4 The IC on the TCP may not be damaged, circuits.	2.5
		12.5 The uppermost edge of the protective strip on the interface pin must be present or look as if it cause the interface pin to sever.	2.5
		12.6 The residual rosin or tin oil of soldering (component or chip component) is not burned into brown or black color.	2.5
		12.7 Sealant on top of the ITO circuit has not hardened.	0.65
		12.8 Pin type must match type in specification sheet.	0.65
		12.9 LCD pin loose or missing pins.	0.65
		12.10 Product packaging must the same as specified on packaging specification sheet.	0.65
		12.11 Product dimension and structure must conform to product specification sheet.	0.65
		12.12 Visual defect outside of VA is not considered to be rejection.	

## **11. Precautions in use of LCD Modules**

- (1) Avoid applying excessive shocks to the module or making any alterations or modifications to it.
- (2) Don't make extra holes on the printed circuit board, modify its shape or change the components of LCD module.
- (3) Don't disassemble the LCM.
- (4) Don't operate it above the absolute maximum rating.
- (5) Don't drop, bend or twist LCM.
- (6) Soldering: only to the I/O terminals.
- (7) Storage: please storage in anti-static electricity container and clean environment.
- (8) Raystar have the right to change the passive components, including R3,R6 & backlight adjust resistors. (Resistors, capacitors and other passive components will have different appearance and color caused by the different supplier.)
- (9) Raystar have the right to change the PCB Rev. (In order to satisfy the supplying stability, management optimization and the best product performance...etc, under the premise of not affecting the electrical characteristics and external dimensions, Raystar have the right to modify the version.)
- (10) To ensure the stability of the display screen, please apply screen saver after showing 30 mins of fixed display content.
- (11) Please heat up a little the tape sticking on the components when removing it; otherwise the components might be damaged.

## **12. Material List of Components for RoHs**

1. RAYSTAR Optronics. Inc. hereby declares that all of or part of products (with the mark “#”in code), including, but not limited to, the LCM, accessories or packages, manufactured and/or delivered to your company (including your subsidiaries and affiliated company) directly or indirectly by our company (including our subsidiaries or affiliated companies) do not intentionally contain any of the substances listed in all applicable EU directives and regulations, including the following substances.

Exhibit A : The Harmful Material List

Material	Cd	Pb	Hg	Cr6+	PBB	PBDE	DEHP	BBP	DBP	DIBP
Limited Value	<b>100 ppm</b>	<b>1000 ppm</b>	<b>1000 ppm</b>	<b>1000 ppm</b>	<b>1000 ppm</b>	<b>1000 ppm</b>	<b>1000 ppm</b>	<b>1000 ppm</b>	<b>1000 ppm</b>	<b>1000 ppm</b>

Above limited value is set up according to RoHS.

2. For RoHS compliance, the recommended soldering temperatures for different components are as follows:

(1) FPC : 300°C, 1-3 seconds

(2) Backlight AK and metal pin glass: 330°C, 1-5 seconds

Note: Customers should adjust the temperature and duration based on the actual materials used in their soldering process, including the soldering iron, solder paste, and any other components involved.

## **13. Recommendable Storage**

1. Place the panel or module in the temperature 25°C±5°C and the humidity below 65% RH
2. Do not place the module near organics solvents or corrosive gases.
3. Do not crush, shake, or jolt the module.