

Display Elektronik GmbH

**DATA
SHEET**

TFT MODULE

DEM 10801080A VMH-PW-N

ROUND 5,0" TFT

Product Specification

Version: 0

17.01.2024

Revision History

Date	Rev. No.	Page	Summary
17.01.2025	0	ALL	FIRST ISSUE

Contents

1. Block Diagram	5
3. Input terminal Pin Assignment	6
2. Manufacturer: Hirose	7
4. LCD Optical Characteristics	9
4.1 Optical specification	9
5. Electrical Characteristics	12
5.1 Absolute Maximum Rating	12
5.2 DC Electrical Characteristics	12
5.4 LED Backlight Characteristics	13
6. SIGNAL TIMING SPECIFICATION	15
6.1 Vertical Timing	15
6.2 Horizontal Timing	16
6.3 Reset timing	17
7.0 POWER ON/OFF SEQUENCE	18
7. LCD Module Out-Going Quality Level	19
7.1 VISUAL & FUNCTION INSPECTION STANDARD	19
7.1.1 Inspection conditions	19
7.1.2 Definition	19
7.1.3 Sampling Plan	19
7.1.4 Criteria (Visual)	21
8. Reliability Test Result	24
9. Cautions and Handling Precautions	25
9.1 Handling and Operating the Module	25
9.2 Storage and Transportation.	25

*** Description**

This is a color active matrix TFT (Thin Film Transistor) LCD (liquid crystal display) that uses amorphous silicon TFT as a switching device. This module is composed of a transmissive type TFT-LCD Panel, driver circuit, backlight unit. The resolution of a 5.0" TFT-LCD contains 1080xRGBx1080 Pixels and can display up to 16.7 Million colors.

*** Features**

General Information Items	Specification	Unit	Note
	Main Panel		
Display Area (AA)	127.008 x 127.008	Mm	-
Driver Element	TFT Active Matrix	-	-
Display Colors	16.7 Million	colors	-
Number of Pixels	1080 x RGB x 1080	dots	-
TFT Pixel Arrangement	RGB Vertical Stripe	-	-
Pixel Pitch	0.1176 x 0.1176	mm	-
Viewing Angle	ALL	o'clock	-
Controller IC	HX8399 (Himax)	-	-
LCM Interface	1/2/3/4-LANE MIPI	-	-
Display Mode	IPS / Transmissive / Normally Black	-	-
Operating Temperature	-20°C ~ +60°C	°C	-
Storage Temperature	-30°C ~ +75°C	°C	-

*** Mechanical Information**

Item		Min.	Typ.	Max.	Unit	Note
Module Size	Horizontal(H)	-	136.531	-	mm	-
	Vertical(V)	-	132.208	-	mm	-
	Depth(D)	-	1.98	-	mm	-
Weight		-	70	-	g	-

1. Block Diagram

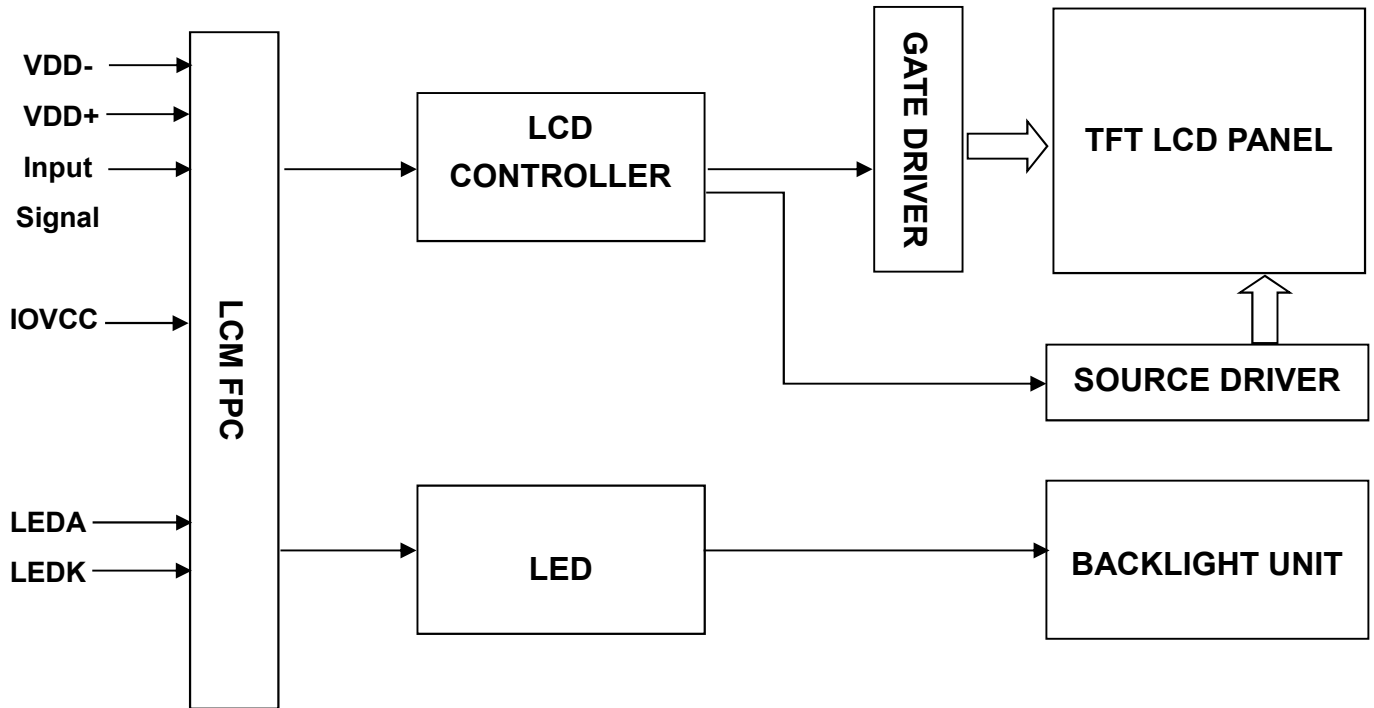

2. Outline Dimension

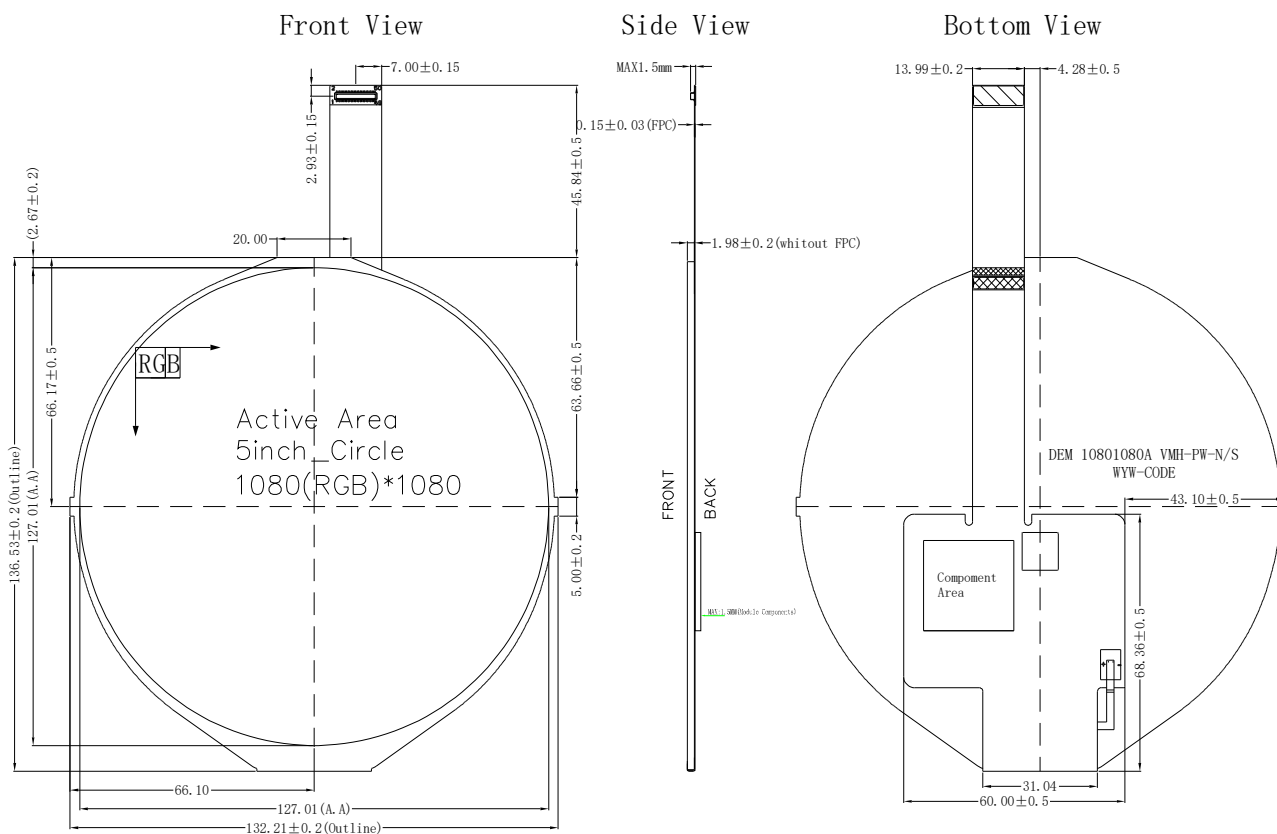

- NOTE:
1. DISPLAY TYPE: 5.0", TFT-LCD, 16.7M COLORS
 2. DISPLAY MODE: ADS Normal Black
 3. VIEWING DIRECTION: ALL
 4. LCM DRIVER IC: HX399C (COG)
LCM Interface: MIPI
 5. VDDIO: 1.8-3.3V (TYP.), VDD: +5.0V/-5.0V
 6. OPERATING TEMP: -20° C TO 60° C
STORAGE TEMP: -30° C TO 75° C
 7. BACK LIGHT: LED WHITE, 6 LED, 20mA, 37.26V
 8. CONNECTOR: DF40C-50DP-0.4V(51), Hirose
 9. RoHS COMPLIANT.

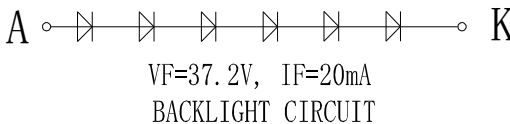

Pin	Signal	Function	Pin	Signal	Function
49	GND	Ground	50	GND	Ground
47	GND	Ground	48	RESET	Disp reset
45	NC	NC	46	TE	Disp tearing effect out
43	NC	NC	44	LEDPWM	Backlight pwm output
41	NC	NC	42	GND	Ground
39	NC	NC	40	NC	NC
37	GND	Ground	38	VDD(+5)	Display +5V analog rail
35	NC	NC	36	VDD(+5)	Display +5V analog rail
33	NC	NC	34	NC	NC
31	GND	Ground	32	VDD(+5)	Display +5V analog rail
29	LAN3_N	Disp MIPI lane 3-	30	VDD(+5)	Display +5V analog rail
27	LAN3_P	Disp MIPI lane 3+	28	NC	NC
25	GND	Ground	26	GND	Ground
23	LAN0_N	Disp MIPI lane 0-	24	IOVCC	Disp digital power
21	LAN0_P	Disp MIPI lane 0+	22	IOVCC	Disp digital power
19	GND	Ground	20	GND	Ground
17	CLK_N	Disp MIPI CLK -	18	ID_PN1	ID pin to GND(BOS)
15	CLK_P	Disp MIPI CLK +	16	ID_PN2	ID pin to 1.8V(BOS)
13	GND	Ground	14	GND	Ground
11	LAN1_N	Disp MIPI lane 1-	12	LEDA	LED Anode
9	LAN1_P	Disp MIPI lane 1+	10	LEDA	LED Anode
7	GND	Ground	8	GND	Ground
5	LAN2_N	Disp MIPI lane 2-	6	LEDC	LED cathode
3	LAN2_P	Disp MIPI lane 2+	4	LEDC	LED cathode
1	GND	Ground	2	GND	Ground

3. Input Terminal Pin Assignment

NOTE: Connector Model Number: DF40C-50DP-0.4V (Manufacturer: Hirose)

NO	SYMBOL	DISCRIPTION	I/O
1	GND	Ground.	P
2	GND	Ground.	P
3	LAN2_P	Disp MIPI lane2+.	I
4	LEDK	LED cathode.	P
5	LAN2_N	Disp MIPI lane2-.	I
6	LEDK	LED cathode.	P
7.	GND	Ground.	P
8	GND	Ground.	P
9	LAN1_P	Disp MIPI Blane 1+.	I
10	LEDA	LED Anode.	P
11	LAN1_N	Disp MIPI lane 1-.	I
12	LEDA	LED Anode.	P
13	GND	Ground.	P
14	GND	Ground.	P
15	CLK_P	Disp MIPICLK+.	I
16	ID_PIN2	ID pu to1.8V(LCM). If not used open.	P
17	CLK_N	Disp MIPICLK-.	I
18	ID_PIN1	ID pd to GND(LCM). If not used open.	P
19	GND	Ground.	P
20	GND	Ground.	P
21	LAN0_P	Disp MIPI lane 0+.	I
22	IOVCC	Disp digital power(1.8V).	P
23	LAN0_N	Disp MIPI lane0-.	I
24	IOVCC	Disp digital power(1.8V).	P
25	GND	Ground.	P
26	GND	Ground.	P

27	LAN3_P	Disp MIPI lane 3+.	I
28	NC	NC	
29	LAN3_N	Disp MIPI lane 3-.	I
30	VSN/VDD-	Display -5V analog rail.	P
31	GND	Ground.	P
32	VSN/VDD-	Display -5V analog rail.	P
33	NC	NC	
34	NC	NC	
35	NC	NC	
36	VSP/VDD+	Disp +5V analog rail.	P
37	GND	Ground.	P
38	VSP/VDD+	Disp +5V analog rail .	P
39	NC	NC	
40	NC	NC	
41	NC	NC	
42	GND	Ground.	P
43	NC		
44	LEDPWM	Backlight pwm output, If not used open.	O
45	NC	NC	
46	TE	Disp tearing effect out, If not used open.	O
47	GND	Ground.	P
48	RESET	Disp reset.	I
49	GND	Ground.	P
50	GND	Ground.	P

4. LCD Optical Characteristics

4.1 Optical Specification

Item		Symbol	Condition	Min.	Typ.	Max.	Unit.	Note
Contrast Ratio		CR	Θ=0 Normal Viewing Angle	800	1200	--		*NOTE 2
Response Time	Rising	T _R +T _F		--	--	40	msec	*NOTE 4
	Falling							
Color Gamut		S(%)		60	65	--	%	*NOTE 1
LCM Color Filter Chromaticity	White	W _X		0.2422	0.2822	0.3222		CA310 Module
		W _Y		0.2597	0.2957	0.3357		
	Red	R _X		0.5938	0.6338	0.6738		
		R _Y		0.3075	0.3475	0.3875		
	Green	G _X		0.2641	0.3041	0.3441		
		G _Y		0.5093	0.5493	0.5893		
	Blue	B _X		0.1064	0.1464	0.1864		
		B _Y		0.0126	0.0526	0.0926		
Viewing Angle	Hor.	Θ _L	CR>10	70	80	--		*NOTE 5
		Θ _R		70	80	--		
	Ver.	Θ _U		70	80	--		
		Θ _D		70	80	--		
Option View Direction		ALL						

*The data comes from the LCD specification

Measuring Condition

Measuring surrounding: dark room

Ambient temperature: 25°C±2°C

15min. warm-up time.

Measuring Equipment

FPM520 of Westar Display technologies, INC., which utilized SR-3 for Chromaticity and BM-5A for other optical characteristics.

Note (1): Definition of Viewing Angle:

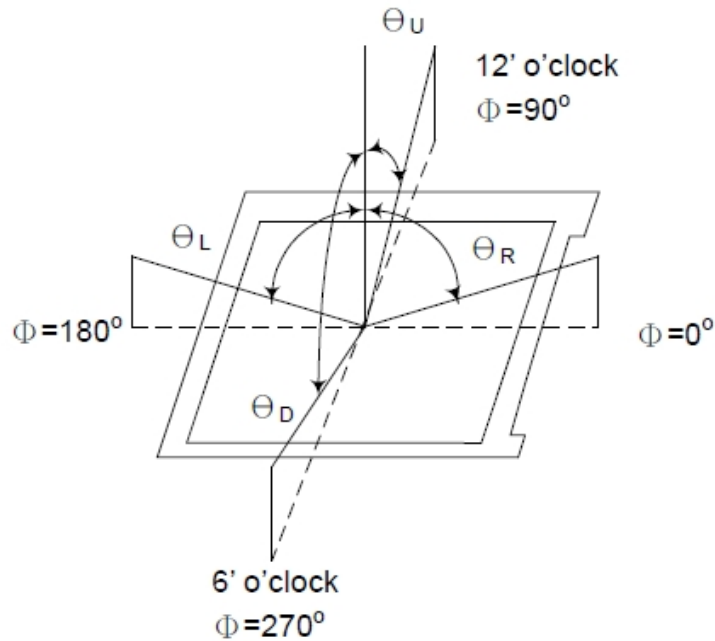

Note (2): Definition of Contrast Ratio(CR) :measured at the center point of panel

$$CR = \frac{\text{Luminance with all pixels white}}{\text{Luminance with all pixels black}}$$

Note (3): Response Time

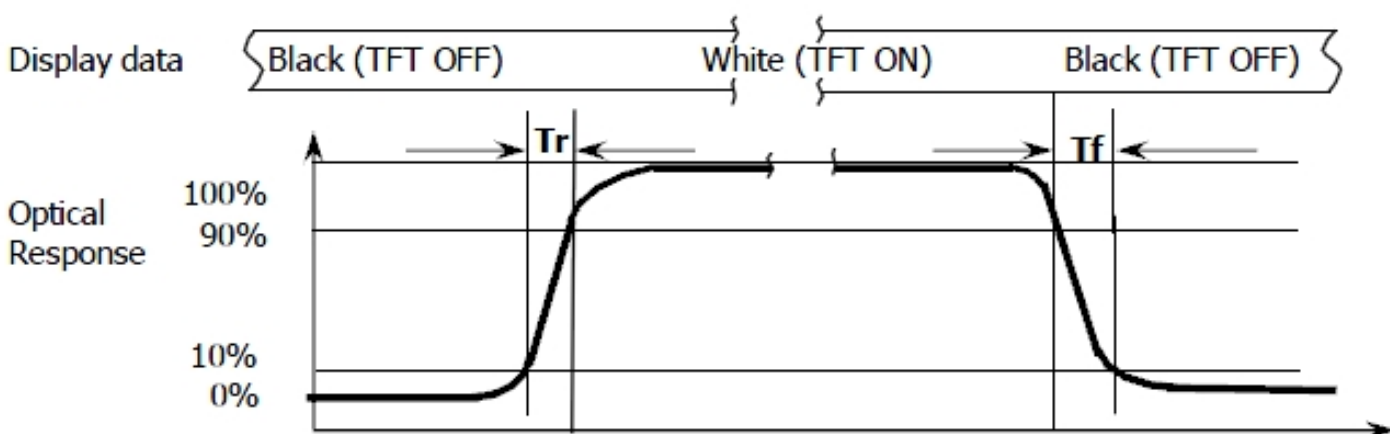

Note (4): Definition of optical measurement setup

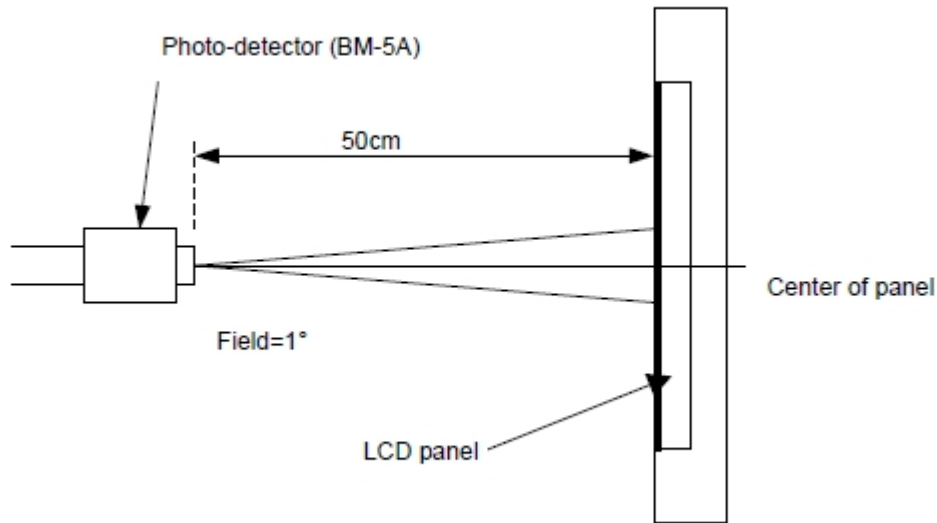

5. Electrical Characteristics

5.1 Absolute Maximum Rating

Characteristics	Symbol	Min.	Max.	Unit	Note
Logic Power Supply Voltage	IOVCC	-0.3	3.6	V	Note1
Analog Positive Power Supply	VDD+/VSP	-0.3	+6.6	V	-
Analog Negative Power Supply	VDD-/VSN	0	-6.6	V	-
Operating Temperature	T _{OP}	-20	+60	°C	-
Storage Temperature	T _{ST}	-30	+75	°C	-

NOTE1: If the absolute maximum rating of even is one of the above parameters is exceeded even momentarily, the quality of the product may be degraded. Absolute maximum ratings, therefore, specify the values exceeding which the product may be physically damaged. Be sure to use the product within the range of the absolute maximum ratings.

5.2 DC Electrical Characteristics

Characteristics	Symbol	Min.	Typ.	Max.	Unit	Note
Power Supply Input Voltage	IOVCC	1.65	1.8	3.3	V	--
Analog Positive Power Supply	VDD+/VSP	4.8	5.0	6.0	V	--
Analog Negative Power Supply	VDD-/VSP	-6.0	-5.0	-4.8	V	--
Normal mode Current	IOIDD	--	17	34	mA	--
Low Level Input Voltage	V _{IL}	0	--	0.3*IOVCC	V	--
High Level Input Voltage	V _{IH}	0.7*IOVCC	--	IOVCC	V	--

5.4 LED Backlight Characteristics

The backlight system is edge-lighting type with 12 chips LED

Item	Symbol	Min.	Typ.	Max.	Unit	Note
Forward Current	I _F	15	20	--	mA	-
Forward Voltage	V _F	--	37.2	38.4	V	-
LCM Luminance	LV	250	300	--	cd/m ²	Note3
LED Lifetime	Hr	--	30000	--	Hour	Note1,2
Uniformity	Avg	70	--	--	%	Note3

Note1: LED life time (Hr) can be defined as the time in which it continues to operate under the condition: Ta=25°C±3°C, typical IL value indicated in the above table until the brightness becomes less than 50%.

Note 2: The “LED life time” is defined as the module brightness decrease to 50% original brightness at Ta=25°C and IL=20mA. The LED lifetime could be decreased if operating IL is larger than 20mA.

The constant current driving method is suggested.



VF=37.2V, IF=20mA
BACKLIGHT CIRCUIT

Note (3) Luminance Uniformity of these 9 points is defined as below:

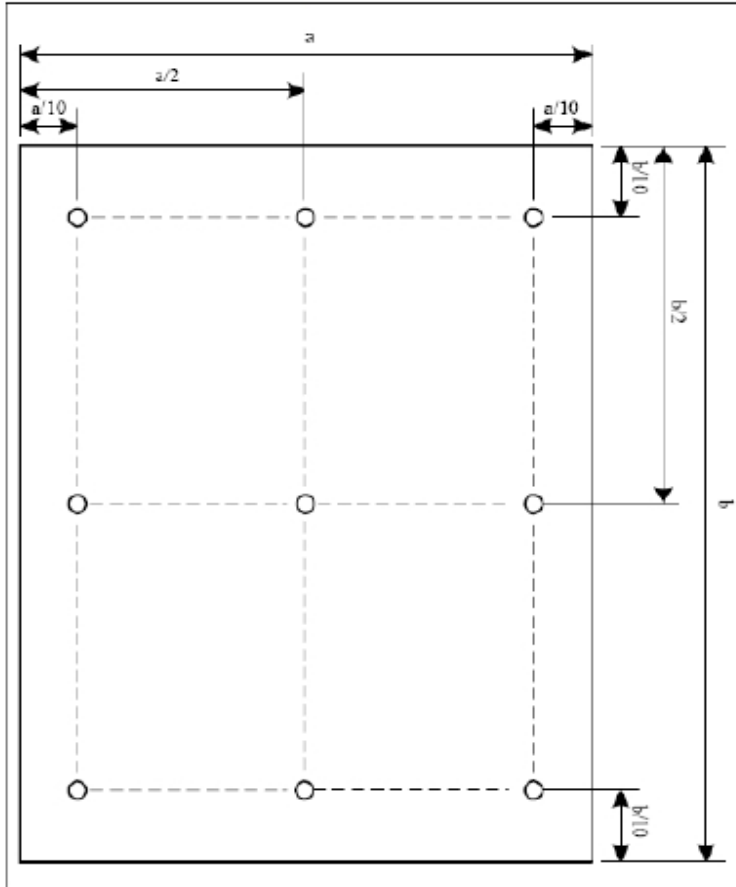

$$\text{Uniformity} = \frac{\text{minimum luminance in 9 points (1-9)}}{\text{maximum luminance in 9 points (1-9)}}$$

$$\text{Luminance} = \frac{\text{Total Luminance of 9 points}}{9}$$

6. SIGNAL TIMING SPECIFICATION

6.1 Vertical Timing

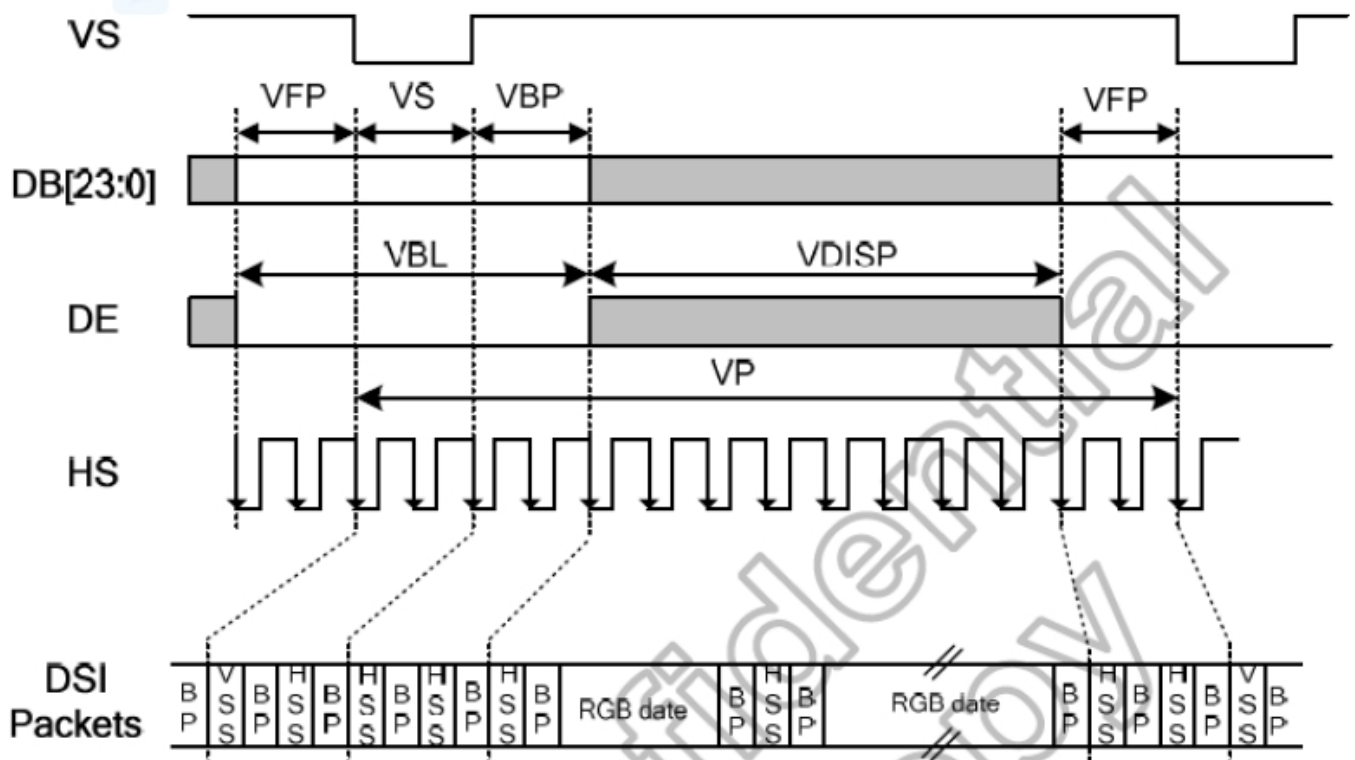

Vertical Resolution=528+8xNL (VSSA=0V, VDD1=1.8V, VDD3=2.8V, T_A=25°C)

Parameter	Symbol	Condition	Spec.			Unit
			Min.	Typ.	Max.	
Vertical cycle	VP	-	534+8xNL	-	-	Line
Vertical low pulse width	VS	-	2	-	Note ⁽¹⁾	Line
Vertical front porch	VFP	-	2	-	-	Line
Vertical back porch	VBP	-	2	-	Note ⁽¹⁾	Line
Vertical data start point	-	VS+VBP	4	-	Note ⁽¹⁾	Line
Vertical blanking period	VBL	VS+VBP+VFP	6	-	-	Line
Vertical active area	-	VDISP	-	528+8xNL	-	Line
Vertical Refresh rate	VRR	-	-	60	-	Hz

Note: (1) The VS and VBP pulse width are related to GSP and GCK timing. The GSP and GCK must be set at corresponding position for LCD normal display.

6.2 Horizontal Timing

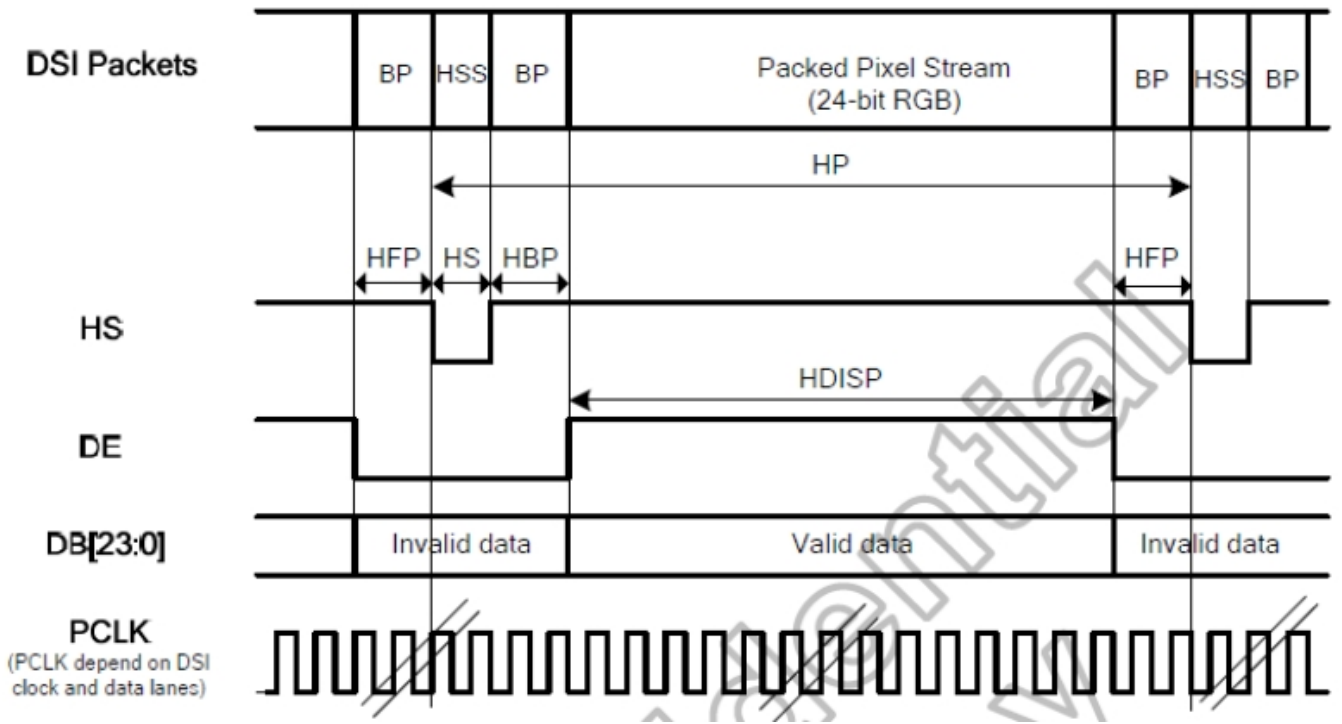

6.3 Reset Timing

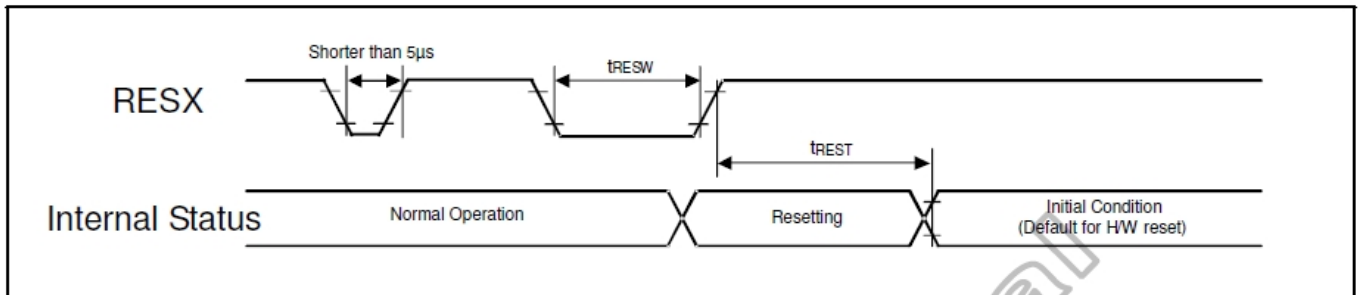

Figure 8.12: Reset input timing

Symbol	Parameter	Related pins	Spec.			Unit	Note
			Min.	Typ.	Max.		
t_{RESW}	Reset low pulse width ⁽¹⁾	RESX	10	-	-	μs	-
t_{REST}	Reset complete time ⁽²⁾	-	-	-	50	ms	-

Note: (1) Spike due to an electrostatic discharge on RESX line does not cause irregular system reset according to the table below.

RESX Pulse	Action
Shorter than 5 μs	Reset Rejected
Longer than 10 μs	Reset
Between 5 μs and 10 μs	Reset Start

(2) During Reset Complete Time, OTP will be latched to internal register during this period. This loading is done every time when there is H/W reset complete time (t_{REST}) within 5ms after a rising edge of RESX.

(3) Spike Rejection also applies during a valid reset pulse as shown below:

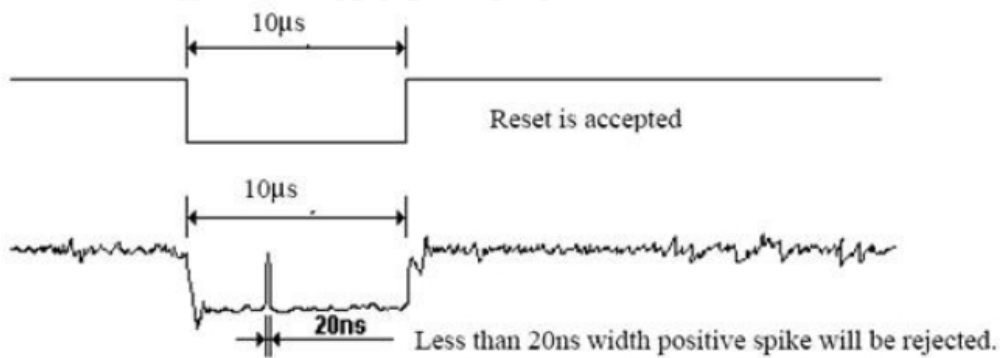

7.0 POWER ON/OFF SEQUENCE

Power on/off Sequence

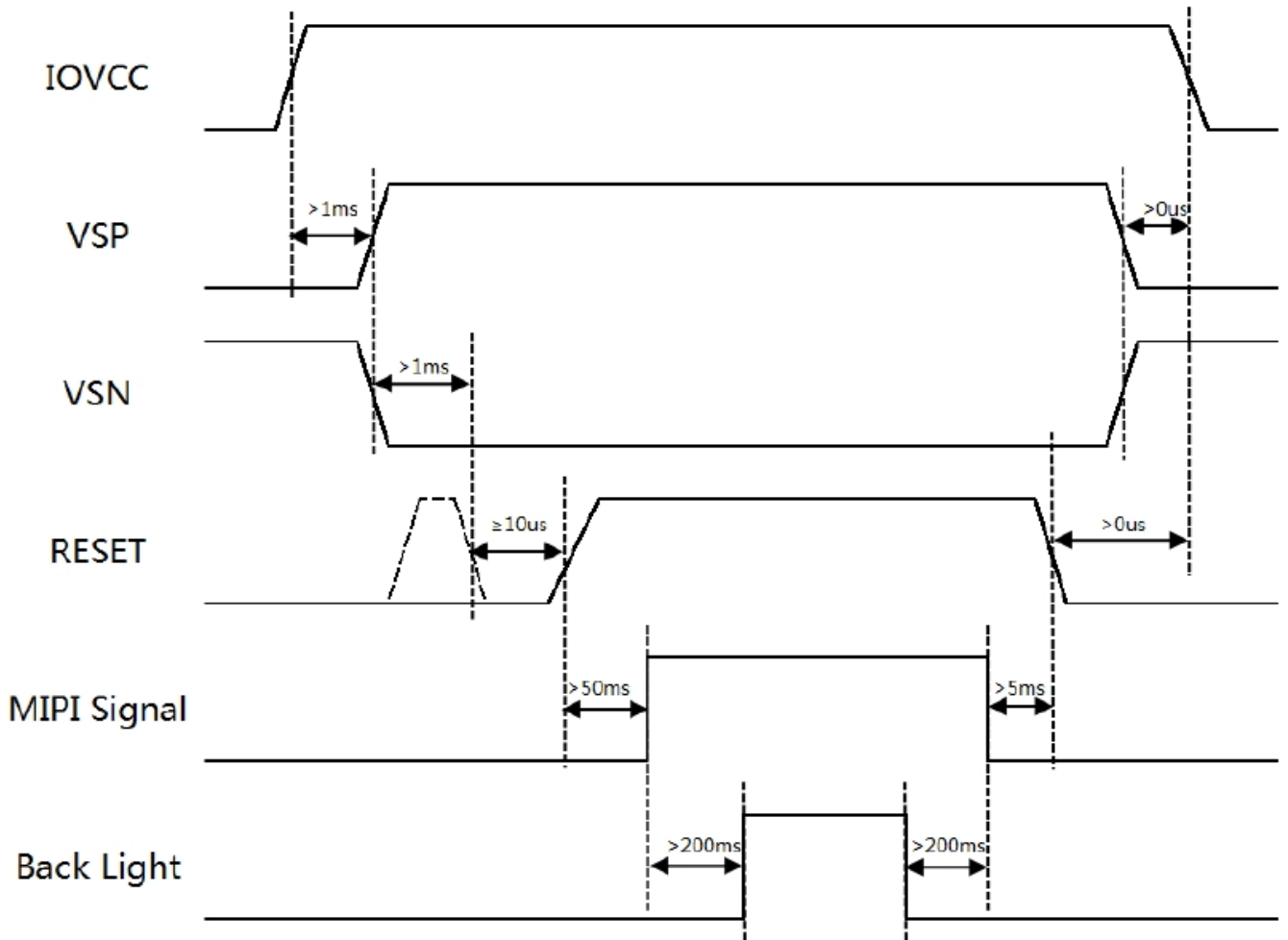

7. LCD Module Out-Going Quality Level

7.1 VISUAL & FUNCTION INSPECTION STANDARD

7.1.1 Inspection Conditions

Inspection performed under the following conditions is recommended.

Temperature: 25°C±5°C

Humidity: 65%±10%RH

Viewing Angle: Normal viewing Angle.

Illumination: Single fluorescent lamp (300 to 700Lux)

Viewing distance: 30-50cm

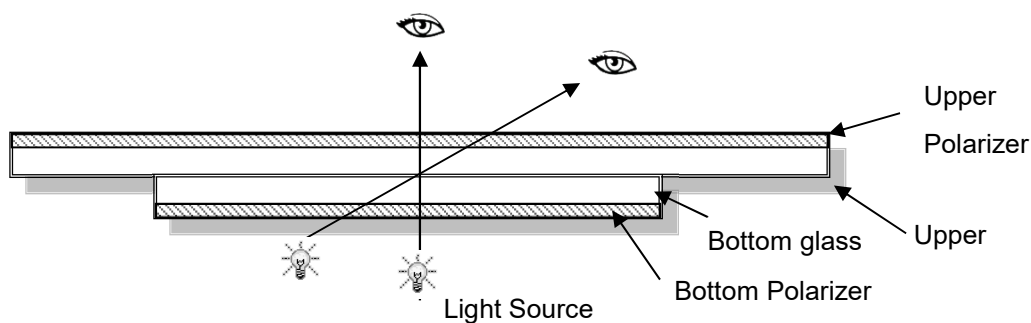

7.1.2 Definition

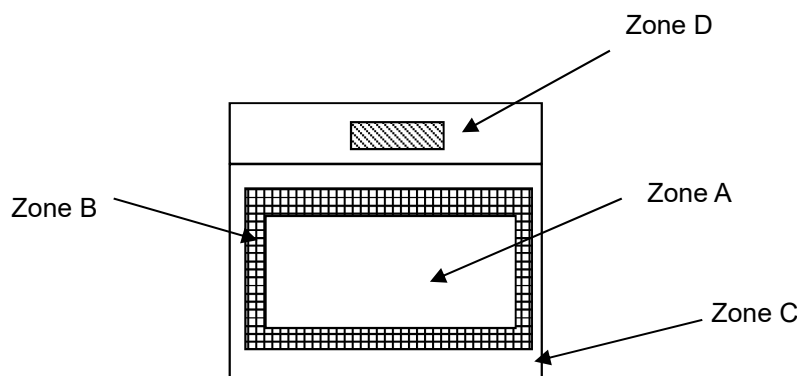

Zone A : Effective Viewing Area(Character or Digit can be seen)

Zone B : Viewing Area except Zone A

Zone C : Outside (Zone A+Zone B) which can not be seen after assembly by customer .)

Zone D : IC Bonding Area

Note: As a general rule ,visual defects in Zone C can be ignored when it doesn't effect product function or appearance after assembly by customer

7.1.3 Sampling Plan

According to GB/T 2828.1-2003, normal inspection, Class II

AQL:

Major Defect	Minor Defect
0.65	1.5

LCD: Liquid Crystal Display, TP: Touch Panel, LCM: Liquid Crystal Module

No	Items to be inspected	Criteria	Classification of defects
1	Functional defects	1) No display, Open or miss line 2) Display abnormally, Short 3) Backlight no lighting, abnormal lighting. 4) TP no function	Major
2	Missing	Missing component	
3	Outline dimension	Overall outline dimension beyond the drawing is not allowed	
4	Color tone	Color unevenness, refer to limited sample	Minor
5	Spot Line defect	Light dot, Dim spot, Polarizer Bubble ; Polarizer accidented spot.	
6	Soldering appearance	Good soldering, Peeling off is not allowed.	
7	LCD/Polarizer/TP	Black/White spot/line, scratch, crack, etc.	

7.1.4 Criteria (Visual)

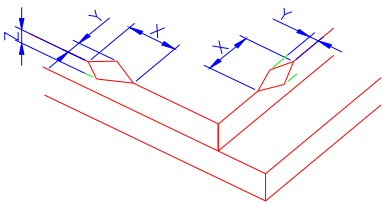
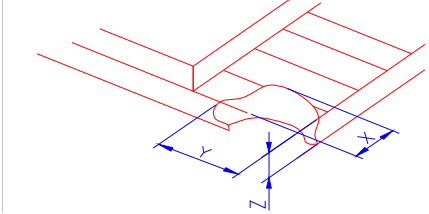
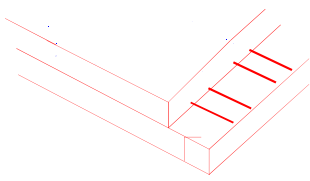
Number	Items	Criteria(mm)						
1.0 LCD Crack/Broken NOTE: X: Length Y: Width Z: Height L: Length of ITO, T: Height of LCD	(1) The edge of LCD broken	 <table border="1" data-bbox="751 611 1453 759"> <thead> <tr> <th>X</th> <th>Y</th> <th>Z</th> </tr> </thead> <tbody> <tr> <td>≤3.0mm</td> <td><Inner border line of the seal</td> <td>≤T</td> </tr> </tbody> </table>	X	Y	Z	≤3.0mm	<Inner border line of the seal	≤T
X	Y	Z						
≤3.0mm	<Inner border line of the seal	≤T						
	(2) LCD corner broken	 <table border="1" data-bbox="831 1068 1374 1167"> <thead> <tr> <th>X</th> <th>Y</th> <th>Z</th> </tr> </thead> <tbody> <tr> <td>≤3.0mm</td> <td>≤L</td> <td>≤T</td> </tr> </tbody> </table>	X	Y	Z	≤3.0mm	≤L	≤T
X	Y	Z						
≤3.0mm	≤L	≤T						
	(3) LCD crack	 <p style="text-align: center;">Crack Not allowed</p>						

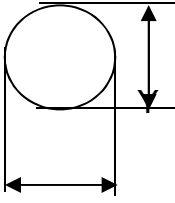
2.0	Spot defect	<p>① light dot (LCD/TP/Polarizer black/white spot , light dot, pinhole, dent, stain)</p> <table border="1"> <thead> <tr> <th rowspan="2">Zone Size (mm)</th> <th colspan="3">Acceptable Qty</th> </tr> <tr> <th>A</th> <th>B</th> <th>C</th> </tr> </thead> <tbody> <tr> <td>$\Phi \leq 0.10$</td> <td colspan="3">Ignore</td> </tr> <tr> <td>$0.10 < \Phi \leq 0.25$</td> <td colspan="3">3(distance $\geq 10\text{mm}$)</td> </tr> <tr> <td>$0.25 < \Phi \leq 0.3$</td> <td colspan="3">2</td> </tr> <tr> <td>$\Phi > 0.35$</td> <td colspan="3">0</td> </tr> </tbody> </table> <p>② Dim spot (LCD/TP/Polarizer dim dot, light leakage, dark spot)</p> <table border="1"> <thead> <tr> <th rowspan="2">Zone Size (mm)</th> <th colspan="3">Acceptable Qty</th> </tr> <tr> <th>A</th> <th>B</th> <th>C</th> </tr> </thead> <tbody> <tr> <td>$\Phi \leq 0.1$</td> <td colspan="3">Ignore</td> </tr> <tr> <td>$0.10 < \Phi \leq 0.25$</td> <td colspan="3">3(distance $\geq 10\text{mm}$)</td> </tr> <tr> <td>$0.25 < \Phi \leq 0.3$</td> <td colspan="3">2</td> </tr> <tr> <td>$\Phi > 0.35$</td> <td colspan="3">0</td> </tr> </tbody> </table> <p>③ Polarizer accidented spot</p> <table border="1"> <thead> <tr> <th rowspan="2">Zone Size (mm)</th> <th colspan="3">Acceptable Qty</th> </tr> <tr> <th>A</th> <th>B</th> <th>C</th> </tr> </thead> <tbody> <tr> <td>$\Phi \leq 0.2$</td> <td colspan="3">Ignore</td> </tr> <tr> <td>$0.3 < \Phi \leq 0.5$</td> <td colspan="3">2(distance $\geq 10\text{mm}$)</td> </tr> <tr> <td>$\Phi > 0.5$</td> <td colspan="3">0</td> </tr> </tbody> </table> <p>④ Pixel bad points (light dot, Dim dot, color dot)</p> <table border="1"> <thead> <tr> <th rowspan="2">Zone Size (mm)</th> <th colspan="3">Acceptable Qty</th> </tr> <tr> <th>A</th> <th>B</th> <th>C</th> </tr> </thead> <tbody> <tr> <td>$\Phi \leq 0.1$</td> <td colspan="3">Ignore</td> </tr> <tr> <td>$0.15 < \Phi \leq 0.25$</td> <td colspan="3">2(distance $\geq 10\text{mm}$)</td> </tr> <tr> <td>$\Phi > 0.3$</td> <td colspan="3">0</td> </tr> </tbody> </table> <p>⑤ Polarizer Bubble</p> <table border="1"> <thead> <tr> <th rowspan="2">Zone Size (mm)</th> <th colspan="3">Acceptable Qty</th> </tr> <tr> <th>A</th> <th>B</th> <th>C</th> </tr> </thead> <tbody> <tr> <td>$\Phi \leq 0.2$</td> <td colspan="3">Ignore</td> </tr> <tr> <td>$0.3 < \Phi \leq 0.4$</td> <td colspan="3">3(distance $\geq 10\text{mm}$)</td> </tr> <tr> <td>$0.4 < \Phi \leq 0.5$</td> <td colspan="3">2</td> </tr> <tr> <td>$\Phi > 0.5$</td> <td colspan="3">0</td> </tr> </tbody> </table>	Zone Size (mm)	Acceptable Qty			A	B	C	$\Phi \leq 0.10$	Ignore			$0.10 < \Phi \leq 0.25$	3(distance $\geq 10\text{mm}$)			$0.25 < \Phi \leq 0.3$	2			$\Phi > 0.35$	0			Zone Size (mm)	Acceptable Qty			A	B	C	$\Phi \leq 0.1$	Ignore			$0.10 < \Phi \leq 0.25$	3(distance $\geq 10\text{mm}$)			$0.25 < \Phi \leq 0.3$	2			$\Phi > 0.35$	0			Zone Size (mm)	Acceptable Qty			A	B	C	$\Phi \leq 0.2$	Ignore			$0.3 < \Phi \leq 0.5$	2(distance $\geq 10\text{mm}$)			$\Phi > 0.5$	0			Zone Size (mm)	Acceptable Qty			A	B	C	$\Phi \leq 0.1$	Ignore			$0.15 < \Phi \leq 0.25$	2(distance $\geq 10\text{mm}$)			$\Phi > 0.3$	0			Zone Size (mm)	Acceptable Qty			A	B	C	$\Phi \leq 0.2$	Ignore			$0.3 < \Phi \leq 0.4$	3(distance $\geq 10\text{mm}$)			$0.4 < \Phi \leq 0.5$	2			$\Phi > 0.5$	0		
	Zone Size (mm)	Acceptable Qty																																																																																																											
A		B	C																																																																																																										
$\Phi \leq 0.10$	Ignore																																																																																																												
$0.10 < \Phi \leq 0.25$	3(distance $\geq 10\text{mm}$)																																																																																																												
$0.25 < \Phi \leq 0.3$	2																																																																																																												
$\Phi > 0.35$	0																																																																																																												
Zone Size (mm)	Acceptable Qty																																																																																																												
	A	B	C																																																																																																										
$\Phi \leq 0.1$	Ignore																																																																																																												
$0.10 < \Phi \leq 0.25$	3(distance $\geq 10\text{mm}$)																																																																																																												
$0.25 < \Phi \leq 0.3$	2																																																																																																												
$\Phi > 0.35$	0																																																																																																												
Zone Size (mm)	Acceptable Qty																																																																																																												
	A	B	C																																																																																																										
$\Phi \leq 0.2$	Ignore																																																																																																												
$0.3 < \Phi \leq 0.5$	2(distance $\geq 10\text{mm}$)																																																																																																												
$\Phi > 0.5$	0																																																																																																												
Zone Size (mm)	Acceptable Qty																																																																																																												
	A	B	C																																																																																																										
$\Phi \leq 0.1$	Ignore																																																																																																												
$0.15 < \Phi \leq 0.25$	2(distance $\geq 10\text{mm}$)																																																																																																												
$\Phi > 0.3$	0																																																																																																												
Zone Size (mm)	Acceptable Qty																																																																																																												
	A	B	C																																																																																																										
$\Phi \leq 0.2$	Ignore																																																																																																												
$0.3 < \Phi \leq 0.4$	3(distance $\geq 10\text{mm}$)																																																																																																												
$0.4 < \Phi \leq 0.5$	2																																																																																																												
$\Phi > 0.5$	0																																																																																																												
	 <p>$\Phi = (X+Y)/2$</p>																																																																																																												

3.0	Line defect (LCD/TP /Polarizer backlight black/white line, scratch, stain)	<table border="1"> <thead> <tr> <th rowspan="2">Width(mm)</th> <th rowspan="2">Length(m m)</th> <th colspan="3">Acceptable Qty</th> </tr> <tr> <th>A</th> <th>B</th> <th>C</th> </tr> </thead> <tbody> <tr> <td>$\Phi \leq 0.05$</td> <td>Ignore</td> <td colspan="2">Ignore</td> <td rowspan="3">Ignore</td> </tr> <tr> <td>$0.05 < W \leq 0.06$</td> <td>$L \leq 3.0$</td> <td colspan="2">$N \leq 2$</td> </tr> <tr> <td>$0.07 < W \leq 0.08$</td> <td>$L \leq 2.0$</td> <td colspan="2">$N \leq 1$</td> </tr> <tr> <td>$0.08 < W$</td> <td colspan="4">Define as spot defect</td> </tr> </tbody> </table>	Width(mm)	Length(m m)	Acceptable Qty			A	B	C	$\Phi \leq 0.05$	Ignore	Ignore		Ignore	$0.05 < W \leq 0.06$	$L \leq 3.0$	$N \leq 2$		$0.07 < W \leq 0.08$	$L \leq 2.0$	$N \leq 1$		$0.08 < W$	Define as spot defect			
		Width(mm)			Length(m m)	Acceptable Qty																						
			A	B		C																						
		$\Phi \leq 0.05$	Ignore	Ignore		Ignore																						
		$0.05 < W \leq 0.06$	$L \leq 3.0$	$N \leq 2$																								
$0.07 < W \leq 0.08$	$L \leq 2.0$	$N \leq 1$																										
$0.08 < W$	Define as spot defect																											
4.0	Electronic Components SMT	Not allow missing parts, solderless connection, cold solder joint, mismatch, The positive and negative polarity opposite																										
5.0	Display color & Brightness	1. Color: Measuring the color coordinates, The measurement standard according to the datasheet or samples. 2. Brightness: Measuring the brightness of White screen, The measurement standard according to the datasheet or Samples.																										
6.0	LCD Mura	By 5% ND filter invisible.																										

Criteria (functional items)

Number	Items	Criteria (mm)
1	No display	Not allowed
2	Missing segment	Not allowed
3	Short	Not allowed
4	Backlight no lighting	Not allowed
5	TP no function	Not allowed

8. Reliability Test Result

Remark:

Item	Condition	Inspection after test
High Temperature Operating	60°C,96h	Inspection after 2~4hours storage at room temperature, the sample shall be free from defects: 1. Air bubble in the LCD; 2. Non-display; 3. Missing segments/line; 4. Glass crack; 5. Current IDD is twice higher than initial value.
Low Temperature Operating	-20°C, 96h	
High Temperature Storage	75°C, 96h	
Low Temperature Storage	-30°C, 96h	
High Temperature & High Humidity Operating	+60°C, 90% RH ,96h	
Thermal Shock (Non-operation)	-10°C, 30 min ↔ +60°C, 30 min, Change time: 5min 20CYC.	
ESD test	C=150pF, R=330,5points/panel Air:±6kV, 5times; Contact:±4kV, 5 times; (Environment: 15°C~35°C, 30%~60%).	
Vibration (Non-operation)	Frequency range: 10~55Hz, Stroke: 1.5mm Sweep: 10Hz~55Hz~10Hz 2 hours for each direction of X.Y.Z. (6 hours for total)	
Box Drop Test	1 Corner 3 Edges 6 faces,80cm(MEDIUM	

1. The test samples should be applied to only one test item.
2. Sample size for each test item is 5~10pcs.
3. For Damp Proof Test, Pure water (Resistance > 10MΩ) should be used.
4. In case of malfunction defect caused by ESD damage, if it would be recovered to normal state after resetting, it would be judged as a good part.
5. Failure Judgment Criterion: Basic Specification, Electrical Characteristic, Mechanical Characteristic, Optical Characteristic.
6. The color fading mura of polarizing filter should not care.

9. Cautions and Handling Precautions

9.1 Handling and Operating the Module

- (1) When the module is assembled, it should be attached to the system firmly.
Do not warp or twist the module during assembly work.
- (2) Protect the module from physical shock or any force. In addition to damage, this may cause improper operation or damage to the module and back-light unit.
- (3) Note that polarizer is very fragile and could be easily damaged. Do not press or scratch the surface.
- (4) Do not allow drops of water or chemicals to remain on the display surface.
If you have the droplets for a long time, staining and discoloration may occur.
- (5) If the surface of the polarizer is dirty, clean it using some absorbent cotton or soft cloth.
- (6) The desirable cleaners are water, IPA (Isopropyl Alcohol) or Hexane.
Do not use ketene type materials (ex. Acetone), Ethyl alcohol, Toluene, Ethyl acid or Methyl chloride. It might permanent damage to the polarizer due to chemical reaction.
- (7) If the liquid crystal material leaks from the panel, it should be kept away from the eyes or mouth. In case of contact with hands, legs, or clothes, it must be washed away thoroughly with soap.
- (8) Protect the module from static; it may cause damage to the CMOS ICs.
- (9) Use finger-stalls with soft gloves in order to keep display clean during the incoming inspection and assembly process.
- (10) Do not disassemble the module.
- (11) Protection film for polarizer on the module shall be slowly peeled off just before use so that the electrostatic charge can be minimized.
- (12) Pins of I/F connector shall not be touched directly with bare hands.
- (13) Do not connect, disconnect the module in the "Power ON" condition.
- (14) Power supply should always be turned on/off by the item 6.1 Power On Sequence & 6.2 Power Off Sequence

9.2 Storage and Transportation.

- (1) Do not leave the panel in high temperature, and high humidity for a long time.
It is highly recommended to store the module with temperature from 0°C to 35°C and relative humidity of less than 70%
- (2) Do not store the TFT-LCD module in direct sunlight.
- (3) The module shall be stored in a dark place. When storing the modules for a long time, be sure to adopt effective measures for protecting the modules from strong ultraviolet radiation, sunlight, or fluorescent light.
- (4) It is recommended that the modules should be stored under a condition where no condensation is allowed. Formation of dewdrops may cause an abnormal operation or a failure of the module.
In particular, the greatest possible care should be taken to prevent any module from being operated where condensation has occurred inside.
- (5) This panel has its circuitry FPC on the bottom side and should be handled carefully in order not to be stressed.